

LECTURE NOTE

On

**Advanced Construction Technique & Equipment
(Th-3)**

SEM-6TH



FACULTY NAME –PARTHASARTHI SAHOO

Department Of Civil Engg.

FIBER AS CONSTRUCTION MATERIAL

Fibers are considered as a construction material to enhance the flexural and tensile strength and as a binder that could combine Portland cement in bonding with cement matrices. Fiber is such a reinforcing material. Fibers are small pieces of reinforcing material possessing certain characteristics and properties. Fibers are usually used in concrete to control cracking due to plastic shrinkage and drying shrinkage.

Types of Fiber:

1. Steel Fibres-

Similar to traditional steel reinforcement, the key characteristic of steel fibers is their high tensile capacity. Steel fibers have been broadly studied in concrete applications, hence, they are commonly used to improve the mechanical properties of concrete.

Research has shown that when steel fibers are used to reinforce concrete structures, there are many improvements in the overall properties. Steel fibers help improve the concrete behaviour in terms of cracking, shrinkage, ductility, toughness, resistance to fatigue, and impact and blast loading. Furthermore, strength properties, such as tensile strength, compressive strength, and flexural strength, are increased for the parent material. This strength increase is due to the steel fibers characteristics of absorbing energy and controlling cracks. Steel fibers can be an ideal additive to specific applications as they possess good electric, magnetic, and heat conductivity.

2. Carbon Fibers-

Carbon fibers have been added in materials to form composites with improved properties. The addition of carbon fibers creates a composite that has outstanding mechanical properties, performs well in high temperature environments, and possesses the benefit of durability. Although carbon fibers are quite brittle, with careful consideration in the design stage, carbon fiber-reinforced composites have excellent properties. The disadvantages of carbon fibers are that due to their excellent properties the expense of manufacturing carbon fibers is high, and the bonding between the fibers and material matrix may be difficult to achieve.

Similar to glass fibers, although there are many positives and benefits to carbon fibers, the production of carbon fibers leads to concerns for the environment and questionable

sustainability. The problem of the disposal of carbon fiber composites at the end of life phase is also well known . For most carbon fiber composites, recycling could be a possibility, however most products are simply burnt or buried , which is not good for the environment

3. Glass Fibers –

Different types of glass exist, with various colours, chemical compositions, and characteristics. Glass fibers have great mechanical properties and excel in terms of strength thermal properties durability and have good interfacial bonding to the matrix .Glass fibers are most frequently used as reinforcement in resins and composites as they have amazing properties in strengthening composites.

Glass fibers are generally used to reinforce polypropylene systems . A composite is formed between the elements to form an excellent material. The resulting composite is cost effective, easy to procure, and possesses the strength and toughness characteristics of glass fiber.

Properties of Fibers

- High tensile strength and modulus of elasticity.
- High resistance to weather and acidic environments, and some alkali resistance.
- Good thermal properties and stability, and can tolerate and perform well in high temperature environments .
- Good electric, electromagnetic, and sound insulation properties.
- Good resistance and stability against corrosion, chemical attack, impact load, and fire .
- Good adhesion and abrasion properties with the ability to mix well with matrix materials.
- Nonreactive and non combustible.
- Low absorption of moisture/water and thermal conductivity.
- Absorb sound and vibration isolation.
- Resistant to radiation and UV light.
- Strong, hard, and rigid.

USE OR APPLICATION

- Improved characteristics and properties, such as strength, toughness, durability, rigidity, and ductility.
- Improved resistance and performance in different environments, and against physical and chemical corrosion and other attacks.
- Improved stability.

- Improved thermal properties and operating temperature.
- Reduction of heat conductivity.
- Reduction of the specific weight and density resulting in a lightweight product that is both energy and cost-efficient.
- Reduction and lower cost of design and installation, as fibres can replace traditional reinforcement methods.
- Reduction of the volume of landfill and saving of energy if a waste product is utilised.
- Prevents the occurrence of shrinkage, cracks, spalling, and swelling.
- Improved environmental-friendliness, economic efficiency, and sustainability, particularly if natural, energy efficient, or waste fibre is used.

PLASTIC AS CONSTRUCTION MATERIAL

Plastic is a general name given to a wide range of synthetic materials that are based on polymers. The construction industry uses plastic for a wide range of applications because of its versatility, strength-to-weight ratio, durability, corrosion resistance, and soon.

Plastic can be manufactured into forms such as; pipes, cables, coverings, panels, films, sheets and so on; and can be formed or expanded to create low-density materials; and be dissolved in solvents.

Some of these plastics main uses in the construction industry are:

Cladding panels, Cables, Pipes and gutters, Windows and doors, Shuttering, Wall linings, Floor covering, Ceiling panels etc

Use of Plastics in Different Aspects of the Construction Industry

1. Flooring

Plastic materials like polyvinyl chloride (PVC) and polyethylene are used to make flooring less prone to wear and tear. It also decreases the sound pollution level and can be cleaned easily.

2. Roofing

To protect the outer surface of the roof from damage, two layers of different plastic materials are required. The upper part is made of colored thermoplastic olefin or vinyl while the lower part consists of polyurethane foam which consumes less energy and keeps the interior of a house cooler.

3. Insulation

Polyurethane spray is frequently used for insulation when constructing green or low energy buildings. Rigid polyurethane foam is known for its high thermal resistance which promotes temperature consistency. Polyurethane foam is also popular because it is lightweight, chemical resistant, and flame retardant. Due to its closed cell nature, polyurethane insulation performs

as an air barrier, resulting in significant energy savings.

4. Wall

A structural insulated panel (SIP) is a sandwich of expanded polystyrene amidst two slim layers of oriented strand board. This type of pre-fab, composite wall board can be transferred to the work place easily for a particular task and provide good support to columns and other associated essentials during renovation.

5. Pipes

Commonly made up of polyvinyl chloride (PVC), CPVC, acrylonitrile butadiene styrene (ABS) or polyethylene, plastic pipes are flexible and very light in weight, making them easy to install. All of these plastic materials are also highly chemical and water resistant, making them suitable for many extreme environments.

6. Windows

Polycarbonate is used to manufacture building windows. This plastic material is strong, clear and very light in weight. Polycarbonate windows are considered more burglar-proof than regular glass windows. Two plastic materials, vinyl and fiberglass, are used commonly in the production of window frames. Fiberglass is extremely strong while vinyl is quite durable and also inexpensive.

7. Doors

Some construction projects use doors made from a stiff polyurethane foam core with a fiber reinforced plastic (FRP) coating. The sandwich structure of these doors makes them incredibly strong.

TYPES:-

1. PVC:-

Polyvinyl chloride (PVC), a synthetic resin made from the polymerization of vinyl chloride. Second only to polyethylene among the plastics in production and consumption, PVC is used in an enormous range of domestic and industrial products, from raincoats and shower curtains to window frames and indoor plumbing. A lightweight, rigid plastic in its pure form, it is also manufactured in a flexible "plasticized" form.

2. RPVC:-

RPVC means Rigid PolyVinyl Chloride which comes from PVC. Polyvinyl chloride (PVC), also known as vinyl, is a common plastic polymer (a polymer being a large molecule). It comes in two basic forms: flexible and rigid (RPVC). RPVC is used in construction (especially pipes), packaging etc. RPVC Pipes with high impact strength & load bearing capacity.

3. HDPE:-

High density polyethylene (HDPE) piping systems have been used for municipal and industrial water applications for over 50 years. Within Building & Construction Division, HDPE pipes are used for ground source geothermal applications, also known as earth energy or geexchange systems.

4. FRP:-

Fiber-reinforced plastic (FRP) (also called fiber-reinforced polymer).FRP bars are used as internal reinforcement for concrete structures. FRP bars, sheets, and strips are used for strengthening of various structures constructed from concrete, masonry, timber, and even steel. Fiber reinforced polymers are used in the construction of special structures requiring electrical neutrality.

5. GRP:-

GRP stands for 'Glass Reinforced Plastic' a material made from a polyester resin, which is reinforced by chopped strand mat glass fibers to form a GRP laminate. It is a very popular composite material to use because not only is it very strong but also surprisingly light.

Types Of Artificial Timbers:

(a) Veneers :

- These are thin sheet of wood, which are obtained by slicing timber or by rotary cutting or by peeling of logs of wood. Now a days, rotary cutting is more common as this produces veneer of large size and reduces amount of joining.
- However, most attractive decorative figures occur on radial face and are obtained by slicing woods like Teak, Mahogany, Walnut, and Oak. Veneers are normally cut from wood at higher moisture content and are dried before application of adhesive and assembly. Then veneers are pressed together using hot processing method.
- Veneers are used in the manufacture of plywood, each veneer being at right angles to the adjacent veneer so that cross sectional movement can be restrained, with the aid of modern high strength adhesives. Veneers are also used in manufacture of hattern board, particle boards.



→ Fig:Veneers

(b) Plywoods :

- Plywoods are formed together by gluing thin sheets of odd numbers of veneers. The sheets are placed in such a way that, grains of one layer are at right angles to the others.
- As a result, on application of load on the sheet, movement in both the directions is reduced. The outer piles are decorative in nature and are called as face piles and the inner ones are called as core or cross band.



→ Fig:Plywoods

Advantages of Plywood :

- (1) It is light in weight, still many times stronger than solid wood of same thickness.
- (2) It is resistant to cracking, warping, splitting and has uniform strength in all the directions.
- (3) It is available in many sizes, and is defect free, easy to cut; bend and variety of decorative finishes are available.
- (4) Movement due to changes in moisture is negligible.

(c) Particle Board :

- In particle boards, particles or chips (obtained from low grade wood, smaller diameter logs derived from thinings, tops of trees etc.) are randomly mixed with strong adhesives and are compressed together under high pressure to form a board.
- In particle board, the movement is randomly oriented in all directions and restraint is dependent on strength and concentration of adhesive.
- Particle board is much weaker than plywood, because, the adhesive joints between the individual chips involve end grains surface. Properties of plywood largely depend upon wood species used, whereas, in particle board, it largely depends upon the adhesives and particle shape.
- If particle of boards are all cubes, the formation of the board will result in large portion of joints involving end grains, thus producing weak boards.



→ Fig: Particle Board

d) Fibre Board :

- Fibre boards also called as pressed woods are rigid boards manufactured using wood waste like saw dust, small pieces of wood etc.
- Wood is chipped into small pieces of about 20 mm size; and boiled in water. These wet particles are then passed to an autoclave, where it is subjected to steam pressure of 2300 kN/m^2 for about $\frac{1}{2}$ minute and thereafter to a pressure of 7000 kN/m^2 for few seconds.



→ Fig: Fibre board

(e) Batten Boards :

- In all these boards, thin veneers are used on faces and are glued to core. Veneers may be decorative or non-decorative. Grains of veneers are at right angle to those of core.
- In batten boards, core consists of about 8 cm wide wooden strips called as battens. If the width of strips is less than 2.5 cm, it is called as block board. In laminated boards, width of core strips is less than 7 mm.
- Batten boards and block boards are used for making partitions, packing cases, furniture paneling, ceiling, interior decoration; bus bodies, etc. however, are liable to crack or split. Laminated boards are stronger than block boards and are not liable to crack or split.





Fig: Batten Boards

Strength Of Artificial Timber

Strength : The artificial timber should be strong enough to withstand the loads whether being applied slowly or suddenly. It should possess enough strength in direct compression and transverse direction.

Miscellaneous Materials

Acoustic Material

Acoustics is the science of sound, including its production, transmission and effects. Acoustics is a board field which embraces music radio, sound reproduction and other fields.

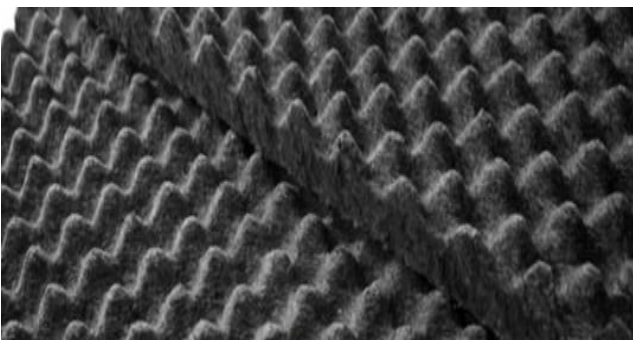

→ Fig:Acoustic Material

Properties of Acoustic Materials :

Following are the various properties of acoustic materials :

- (a) Acoustic material has low reflection and high absorption of sound.
- (b) It controls the sound and noise levels from the machinery and other sources.
- (c) It suppresses reverberation, echoes, resonances and reflection.
- (d) It has capacity to capture and absorb the sound energy.
- (e) It reduces the sound energy waves.

Types of Acoustic Materials :

The acoustical materials can be broadly classified into the following groups :

- (a) **Soft materials :** These have sufficient porosity and are good sound absorbers. Haufelt, asbestos, rock wool, glass silk fall in this category.
- (b) **Semi-hard materials :** These are stiff enough to stand rough handling and can also serve as building panels. Mineral wool boards, cane fibre are included under this category.
- (c) **Hard materials :** These are hard materials which have been made porous during the manufacture. They also serve as protective surfaces. Porous tiles of masonry are commonly employed for this purpose.

Wall Cladding

- Wall cladding or tiling is a process of finishing the surface with tiles. They are fixed upto a height of 1.25 m above the floor level or upto ceiling, in passages, bath rooms, swimming pools, kitchens, staircases, boiler rooms, fire places and sometimes on exterior of building for decorative effect or protection from atmospheric agents.
- They make the wall non-absorbent and easy to clean. The tiles used are either terra cotta, faience, china clay, natural stones like marble. Faience is similar to terra cotta but is twice fired.
- These tiles are available in variety of colours and thickness. They are rectangular, square, rounded or corner type.
- For cladding, the surface of the wall is first plastered with the cement mortar in usual manner and then the tiles, which are immersed in water at least one hour, are covered with a paste of neat cement on back and laid flat against the wall



→ Fig: Wall Cladding

Plaster Boards

- These are large sheets of gypsum plaster faced on both sides with stout paper as reinforcement. Plaster boards are made by mixing gypsum plaster with fine cinders or wood chips and sufficient water to form a thin consistency.
- They are most economical and easy to work due to light in weight. Though the plaster forms best covering on external walls but the use of plastering is not favoured due to following reasons or objections:
 - (a) Plaster does not stick well to the wood work.
 - (b) The cracks are formed on the plastered surface due to extreme temperature variations.
 - (c) The plastered surface required sufficient time for setting and drying.
 - (d) The plastering operation is lengthy process which takes considerable time.
- To overcome the above objections a variety of wall boards are being used now a days. These boards are readily available in the market with different variety. These plaster boards are fire proof in nature, neither expand nor contract due to change in temperature.



→ Fig:Plaster Boards

Micro Silica:

- Micro silica is a light grey cementitious material composed of at least 85 percent ultra fine, amorphous non-crystalline (glassy) spherical silicon dioxide (SiO_2).
- It is also called as silica fume. It is produced as a by-product during the manufacturing of silicon metal or ferrosilicon alloys by reduction of high purity quartz in a submerged-arc electric furnace heated to 2000°C with coal, coke and wood chips as fuel.
- The micro silica, which condenses from the gases escaping from the furnace, has very fine spherical particles having diameter of 0.1 micrometer.
- Ferro silicon alloys are produced with nominal silicon contents 60 to 98 percent. As the silicon content increases in the alloys, the SiO_2 content increases in the micro silica.



→ Fig:Micro Silica

Properties of Micro Silica :

Following are the properties of micro silica :

- (a) Specific gravity of micro silica is 2.20
- (b) Its bulk density varies from 200 to 250 kg/m³.
- (c) It has minimum surface area of 15,000 m²/kg.
- (d) The content of SiO₂ is at least 85 %.
- (e) It gives long term corrosion protections.

Advantages of Micro Silica :

It gives better application when added with Portland cement.

- (a) Micro silica increases the compressive strength.
- (b) It retards the chloride iron diffusion.
- (c) It improves the sulphate resistance.
- (d) It reduces water permeability.
- (e) It improves abrasion and chemical resistance.
- (f) It reduces efflorescences.
- (g) It improves the chemical resistance.

Uses of Micro Silica :

- This material has very recently found its application in our country in the nuclear power plants and bridge construction.
- Micro silica have been used extensively in off-shore concrete platforms, high rise multistoried buildings and various other structures demanding high performance in very aggressive environmental conditions.

Artificial Sand:

- Natural sands are obtained by the weathering action, abrasion of particles of rocks along with flow of stream. Depending on parent rock, action on particles, size and grading of natural river sand varies from place to place.
- Dams are constructed on upstream of river, so now-a-days sands are not available on downstream of dams. At locations, grading of sand available may not contain certain fractions which are required for ideal grading.
- Strength, durability of concrete mix depends on size, shape, grading of fine aggregate. Since good quality sand may not be available, crushed sand is produced. It also helps in protecting ecological balance, by restricting use of natural resources to minimum.
- Artificial sand is a specific purpose produced materials, which will satisfy the strength, durability, size, shape, grading requirement of fine aggregate in concrete mix. The stone metal or crushed stone waste, below 25 mm from good parent rock is fed to disintegrator.



—————> Fig: Artificial Sand

Properties of Artificial Sand :

Following are the properties of artificial sand :

- (a) The density of artificial sand lies in between 18 to 25 kN/m³.
- (b) It does not contain any organic impurities.
- (c) Water absorption in case of artificial sand is almost negligible.
- (d) Specific gravity of artificial sand lies in between 2.65 to 2.8.

Advantages of Artificial Sand :

Following are the advantages of artificial sand :

- (a) Artificial sand is well graded.
- (b) This sand is having superior surface texture.
- (c) It can be compacted properly to reduce voids.
- (d) Less quantity of cement materials required.
- (e) It can be produced in required quantity and desired quality.
- (f) If economy at large is considered, artificial sand, many times proves to be economical.

Bonding Agents

- Bonding agents are natural, compounded or synthetic materials used to enhance the joining of individual members of a structure without using mechanical fasteners.
- These products are often used in repair applications such as the bonding of fresh concrete, sprayed concrete, fresh mortar and old concrete.
- When bonding agents are applied on old concrete, that time surface of old concrete work should be cleaned for proper bonding.
- Following are the various types of emulsion used as bonding agents in the construction work.

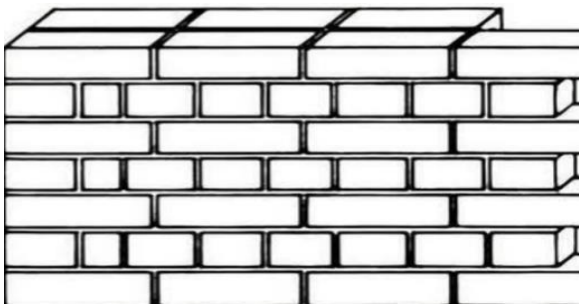

→ Fig: Bonding

Types Of Bonding Agents

(1) Epoxy Latex :

These emulsions are produced from liquid epoxy resins mixed with the curing agents. Most of the epoxy resins are prepared on the job site just before use because phase separation occurs in prepacked emulsions. Equal parts of epoxy and curing agents are mixed, then blended for 2 to 5 minutes and allowed to set for 20 minutes to enable polymerization to begin.

(2) Styrene Butadiene (SBR) :

This latex is compatible with cementitious compounds, which is a copolymer. This latex may coagulate if subjected to high temperatures, freezing temperatures, severe mechanical action for prolonged period of time.

(3) Acrylic Latex :

This type of emulsion is used in the cementitious compounds in much the same manner as SBR latex. Acrylic ester resins are polymers and copolymers of the ester

(4) Polyvinyl Acetate Latex (PVA) :

This type is most widely used as a bonding agent for plaster. Because of its compatibility with cement, it is widely used as a bonding agent and a binder for cementitious water-based paints and water proofing coatings. It is available in two forms: emulsifiable and non-emulsifiable.

(5) Epoxy Bonding Agents :

For the bonding of freshly placed concrete, various products are available. Most products contain resins that are 100 % solids. Products are available in a variety of consistencies, ranging from a highly filled paste (for overhead tank) to liquids with a viscosity of 100 cp, which is similar to water.

Adhesives

- Adhesion is attraction between unlike surfaces. Cohesion is attraction between like surfaces. Usually due to primary or secondary forces of attraction, adhesives are used to join two or more parts into a unit.
- There are advantages of adhesive bonding over methods of assembly like bolting, riveting, welding etc.
- Adhesives join the surfaces in three ways: specific adhesion if surfaces are joined together by intermolecular forces of attraction; mechanic adhesion, if the adhesive fill the voids of porous or rough surfaces and hold the surfaces by interlocking action, and fusion of surfaces which are partially dissolved in the adhesive or its solvent.



→ Fig: Adhesives

Advantages :

- (3) Corrosion may be prevented between different metals joined by adhesives.
- (4) The joints become impermeable for water and gas.
- (5) Adequate strength is produced by using adhesives.
- (6) The adhesive application process is economical, easy and speedy.
- (7) Leakage problem of water can be stopped by the application of adhesives.

Disadvantages :

- (1) Adhesive requires time to attain desired strength.
- (2) Specific adhesive is required to be used for specific substances.
- (3) Adhesives are unstable at high temperature.

Organic Adhesives Are:

1. Animal Protein Glues :

W-2009

These glues are obtained from hide trimmings, bones and flashing by boiling these by hot water. Animal glues provide strong, tough, easily made joints; but they are affected by damp and moist conditions. It is supplied in the form of flakes, pearls, sheets, cakes, granules, cubes or jelly. Animal glues having three grades depending upon the water absorption i.e. 18, 15, 10 times the dry weight of glue.

Use of animal protein glue :

This is used in the manufacture of plywood, laminated timber.

2. Blood Albumin Glues :

W-2009

It is made by drying raw blood and affected by damp and moist conditions. This glue has good water resistance properties and also durable.

Use of blood albumin glues :

They have good adhesive properties for paper, textile and metals, hence largely used in food packaging, leather dressing and for wood working.

3. Casein Adhesive :

It is obtained by curdling skimmed milk by the addition of dilute acid. Casein is separated, mixed with lime and preservatives and sold. Casein for wet mix glue should pass through 60 μ sieves and for dry mix glue should pass through 25 μ sieves shaken for 10 minutes. Casein glue, if properly formulated, proved highly moisture resistant glue joints but not water proof. It has less resistant to bacterial attack.

Use of casein adhesive :

These glues have been used since long to form strong, water-proof wooden joints and to make durable plywoods.

4. Starch Adhesives :

It is made from vegetable starch having good dry strength but not resistant to moisture. Alkali or acid modifiers are used to make starch paste thick and tacky. This glue has poor water resistance but bond quickly to paper and textile. They are cheaper and easier to handle than animal glues.

Use of starch adhesive :

This glue is spread and dried easily, they are used in automatic package machines. These glues are used in the manufacture of low strength and low water resistance plywood.

5. Synthetic Adhesives :

- These are mostly resins used in plastic industry and are classed as thermosetting or thermoplastic glues. Thermosetting glues are permanent, once they are set, but the thermoplastic types can be made plastic again by reheating.
- All of them are strong, water proof and fire-proof and the setting time can be regulated by varying the amount of the hardener.

Prefabrication:

Prefabrication is the practice of assembling components of a structure in a factory or other manufacturing site, and transporting complete assemblies or sub-assemblies to the construction site where the structure is to be located.

History of Prefabrication:

- Prefabrication has been used since ancient times. For example, it is claimed that the world's oldest known engineered roadway, the Sweet Track constructed in England around 3800 BC, employed prefabricated timber sections brought to the site rather than assembled on-site.
- Sinhalese kings of ancient Sri Lanka have used prefabricated buildings technology to erect giant structures, which dates back as far as 2000 years, where some sections were prepared separately and then fitted together, specially in the Kingdom of Anuradhapura and Kingdom of Polonnaruwa.
- The Crystal Palace, erected in London in 1851, was a highly visible example of iron and glass prefabricated construction; it was followed on a smaller scale by Oxford Rewley Road railway station.

Process and Theory:

- The conventional method of building a house is to transport bricks, timber, cement, sand, steel and construction aggregate, etc. to the site, and to construct the house on site from these materials. In prefabricated construction, only the foundations are constructed in this way, while sections of walls, floors and roof are prefabricated (assembled) in a factory (possibly with window and door frames included), transported to the site, lifted into place by a crane and bolted together.
- Prefabrication is used in the manufacture of ships, aircraft and all kinds of vehicles and machines where sections previously assembled at the final point of manufacture are assembled elsewhere instead, before being delivered for final assembly.
- The **theory** behind the method is that time and cost is saved if similar construction tasks can be grouped, and assembly line techniques can be employed in prefabrication at a location where skilled labour is available, while congestion at the assembly site, which wastes time, can be reduced. The method finds application particularly where the structure is composed of repeating units or forms, or where multiple copies of the same basic structure are being constructed. Prefabrication avoids the need to transport so many skilled workers to the construction site, and other restricting conditions such as a lack of power, lack of water, exposure to harsh weather or a hazardous environment are avoided. Against these advantages must be weighed the cost of transporting prefabricated sections and lifting them into position as they will usually be larger, more fragile and more difficult to handle than the materials and components of which they are made.

Uses:

- Prefabrication techniques are used in the construction of apartment blocks, and housing developments with repeated housing units. The quality of prefabricated housing units had increased to the point that they may not be distinguishable from traditionally built units to those that live in them. The technique is also used in office blocks, warehouses and factory buildings. Prefabricated steel and glass sections are widely used for the exterior of large buildings.
- Detached houses, cottages, log cabin, saunas, etc. are also sold with prefabricated elements.
- Prefabrication of modular wall elements allows building of complex thermal insulation, window frame components, etc. on an assembly line, which tends to improve quality over on-site construction of each individual wall or frame.
- Prefabrication saves engineering time on the construction site in civil engineering projects. This can be vital to the success of project such as bridges where weather conditions may only allow brief periods of construction.
- Prefabricated bridge elements and systems offer bridge designers and contractors significant advantages in terms of construction time, safety, environmental impact, constructibility, and cost.
- Prefabrication can also help minimize the impact on traffic from bridge building. Additionally, small, commonly used structures such as concrete pylons are in most cases prefabricated.
- Radio towers for mobile phone and other services often consist of multiple prefabricated sections. Modern lattice towers and guyed masts are also commonly assembled of prefabricated elements.
- Prefabrication has become widely used in the assembly of aircraft and spacecraft, with components such as wings and fuselage sections often being manufactured in different countries or states from the final assembly site.

Advantages:

- Moving partial assemblies from a factory often costs less than moving pre-production resources to each site
- Deploying resources on-site can add costs; prefabricating assemblies can save costs by reducing on-site work
- Factory tools - jigs, cranes, conveyors, etc. - can make production faster and more precise
- Factory tools - shake tables, hydraulic testers, etc. - can offer added quality assurance
- Consistent indoor environments of factories eliminate most impacts of weather on production
- Cranes and reusable factory supports can allow shapes and sequences without expensive on-site falsework.
- Higher-precision factory tools can aid more controlled movement of building heat and air, for lower energy consumption and healthier buildings
- Factory production can facilitate more optimal materials usage, recycling, noise capture, dust capture, etc.

Disadvantages:

- Transportation costs may be higher for voluminous prefabricated sections than for their constituent materials, which can often be packed more densely.
- Large prefabricated sections may require heavy-duty cranes and precision measurement and handling to place in position.

Classification :

The Prefabrication is classified as follow from the view of degree of Precast construction.

1. Small prefabrication
2. Medium Prefabrication
3. Large Prefabrication
4. Off-Site (or) factory Prefabrication
5. Open system of prefabrication
6. Closed system of prefabrication
7. Partial prefabrication
8. Total prefabrication

1.Small Prefabrication :

Elements using in the construction for ex-brick is a small unit precast and used in building. This is called as small prefabrication. That the degree of precast element is very low.

2.Medium Prefabrication :

Suppose the roofing systems and horizontal members are provided with prestressed elements those construction are known as medium prefabricated construction here the degree of precast elements are moderate.

3.Large Prefabrication :

In large prefabrication most of the members like wall panels, roofing /flooring Systems, beams and columns are prefabricated. Here degree of precast elements are high.

4. Off – site (factory) prefabrication :

One of the main factor which affect the factory prefabrication is transport. The mode of transport, vehicles are the factors which prefabrication is to be done on site on factory.

Suppose the factory situated at a long distance from the construction site and the vehicle have to cross a congested traffic with heavy weighed elements the cost in site prefabrication is preferred even though the same condition are the cast in site prefabrication is preferred only when number of houses and more for small elements the conveyance is easier with normal type of lorry and trailers. Therefore we can adopt factory (or) OFF site prefabrication for this type of construction.

5.Open system of prefabrication :

In the total prefabrication systems, the space framers are casted as a single unit and erected at the site. The

wall fitting and other fixing are done on site. This type of construction is known as open system of prefabrication.

6. Closed system of prefabrication :

In this system the whole things are casted with fixings and erected on their position.

7. Partial prefabrication :

In this method of construction the building element (mostly horizontal)required are precast and then erected. Since the costing of horizontal elements (roof/ floor) often take there time due to erection of from work the completion of the building is delayed and hence this method is restored. In most of the building sites this method is popular more. This method is efficient when the elements are readily available when the building reached the roof level. The delay caused due to erection of formwork, delaydue to removal eliminated completely in this method of construction Suitable for any type of building provided lifting and erection equipments are available.

8. Total Prefabrication :

Very high speed can be achieved by using this method of construction. The method can be employed for frame type of construction or for panel type of or the total prefabrication can be on site or off-site. The choice of these two methods depend on the situations when the factory produced elements are transported and erected site we call if off-site prefabrication. If this method is to be adopted then we have a very good transportation of the products to site. If the elements are cast near the building site and erected, the transportation of elements can be eliminated, but we have consider the space availability for establish such facilities though it is temporary. The choice of the method of construction also depends on the following

- a. Type of equipment available for erection and transport.
- b. Type of structural scheme (linear elements or panel)
- c. Type of connections between elements.
- d. Special equipment devised for special method construction

Modular coordination

Modular coordination means the interdependent arrangement of a dimension based on a primary value accepted as a module. The strict observance of rules of modular coordination facilitated,

1. Assembly of single components into large components.
2. Fewest possible different types of component.
3. Minimum wastage of cutting needed.

Modular coordination is the basis for a standardization of a mass production of component.

A set of rules would be adequate for meeting the requirements of conventional and prefabricated construction. These rules are adaptable for,

- a. The planning grid in both directions of the horizontal plan shall be
 1. 3M for residential and institutional buildings,
 2. For industrial buildings,
 - 15M for spans up to 12m
 - 30M for spans between
 - 12m and 18m60M for spans over 18m

The centre lines of load bearing walls shall coincide with the grid lines

b. In case of external walls the grid lines shall coincide with the centre line of the wall or a line on the wall 5 cm from the internal face of the wall.

c. The planning module in the vertical direction shall be 1M up to and including a height of 2.8M.

d. Preferred increments for the still heights, doors, windows and other fenestration shall be 1M.

e. In case of internal columns the grid lines shall coincide with the centre lines of columns. In case of external columns, the grid lines shall coincide with the centre lines of the columns in the storey or a line in the column from the internal face of the column in the topmost storey.

Systems of prefabrication:

System is referred to a particular method of construction of buildings using the prefabricated components which are inter related in functions and are produced to a set of instructions. With certain constraints, several plans are possible, using the same set of components, the degree of flexibility varies from system to system. However in all the systems there is a certain order and discipline. The system of prefabricated construction depends on the extent of the use of prefab components, their characteristics to be considered in devising a system:

- i. Intensified usage of spaces
- ii. Straight and simple walling scheme
- iii. Limited sizes and numbers of components
- iv. Limited opening in bearing walls
- v. Regulated locations of partitions
- vi. Standardized service and stair units
- vii. Limited sizes of doors and windows with regulated positions
- viii. Structural clarity and efficiency
- ix. Suitability for adoption in low rise and high rise blocks
- x. Ease of manufacturing storing and transporting

Principles of Prefabrication

The main reasons to choose Prefabrication Construction method over conventional in situ method.

1. Economy in large scale project with high degree of repetition in work execution.
2. Special architectural requirement in finishing.
3. Fast speed of construction.
4. Constraints in availability of site resources ex-materials & labour etc
5. Other space & environmental constraints.
6. Overall assessment of some or all of the above factors which points to the superiority of adopting precast construction over conventional method.

Earthquake:

- They are natural disasters of a generally unpredictable nature
- It is the shaking of earth due to the movement of earth's crust
- A sudden, rapid shaking of the earth caused by the breaking and shifting of rocks beneath the earth surface.

Earthquake Resistant Structure

If a building is enough to resist earthquake then such building is called earthquake resistant structure.

Earthquake Resistant Structure Techniques:

1. Base isolation:



Figure 13
Piers with the lead-rubber bearings at Bhuj District Hospital

- Introduces flexibility to the structures
- Building is rested on flexible pads (Base Isolators)
- When earthquake strikes the building does not move
- It is suitable for hard soil only

TYPES OF BASE ISOLATOR

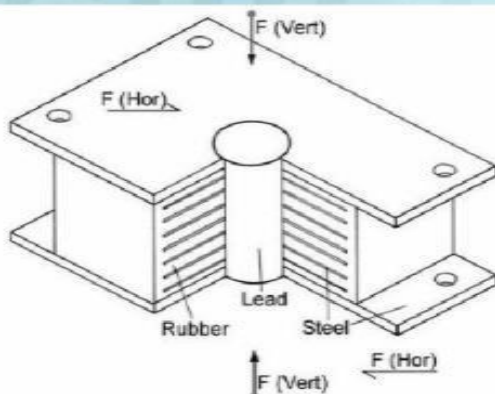

➤ **Lead-Rubber Bearing:-**

- ❖ Frequently used for base isolation
- ❖ made from layers of rubber sandwiched together with layers of steel
- ❖ Very stiff and strong in the vertical direction
- ❖ Flexible in horizontal direction.

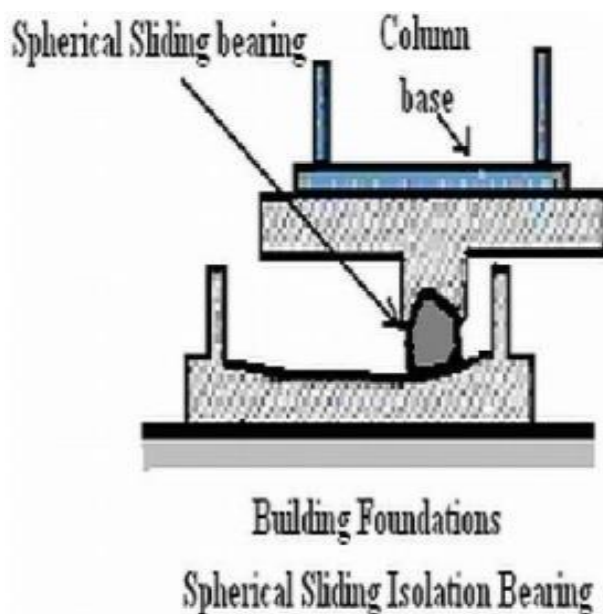

➤ **Spherical Sliding Isolation:-**

- ❖ It uses bearing pads that have a curved surface and low-friction materials similar to Teflon
- ❖ During an earthquake the building is free to slide both horizontally and vertically
- ❖ It will return to its original position after the ground shaking stops.

2. Energy Dissipation Device-Sesimic dampers:

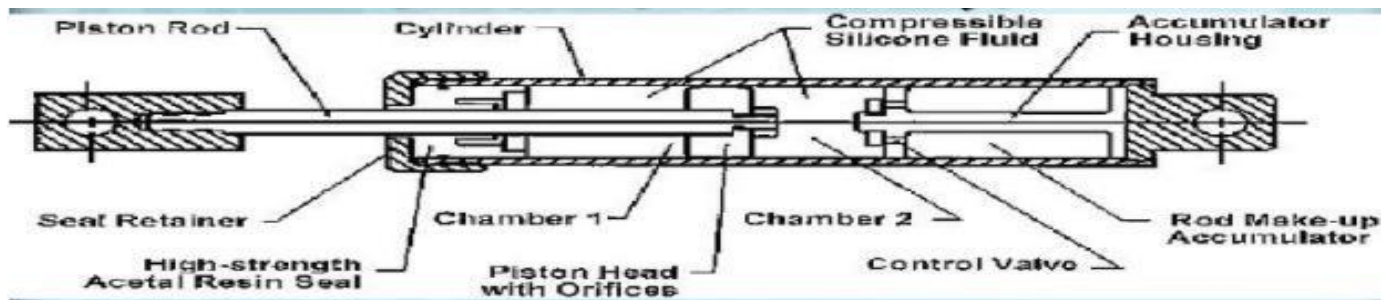

- These are used in place of structural elements such as diagonal braces
- Acts like the hydraulic shock absorbers in cars
- When seismic energy is transmitted through them, dampers absorb part of it, and thus damp the motion of the building.

TYPES OF SEISMIC DAMPERS

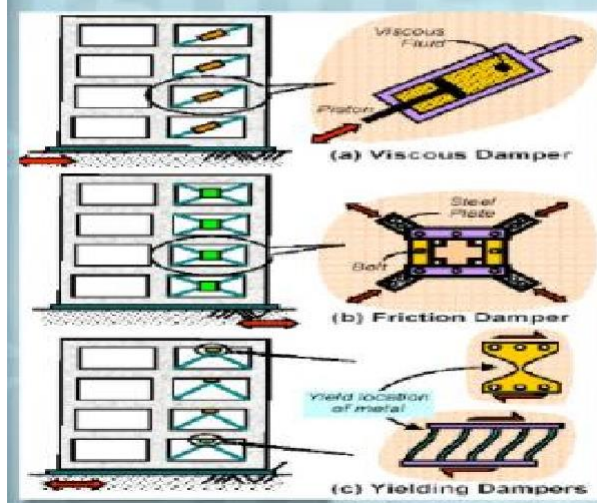

- **Viscous Dampers** (energy is absorbed by silicone-based fluid passing between piston cylinder arrangement)
- **Friction Dampers** (energy is absorbed by surfaces with friction between them rubbing against each other),
- **Yielding Dampers** (energy is absorbed by metallic components that yield).
- **Viscoelastic Dampers** (energy is absorbed by utilizing the controlled shearing of solids)

3. Keeping Building Upright:

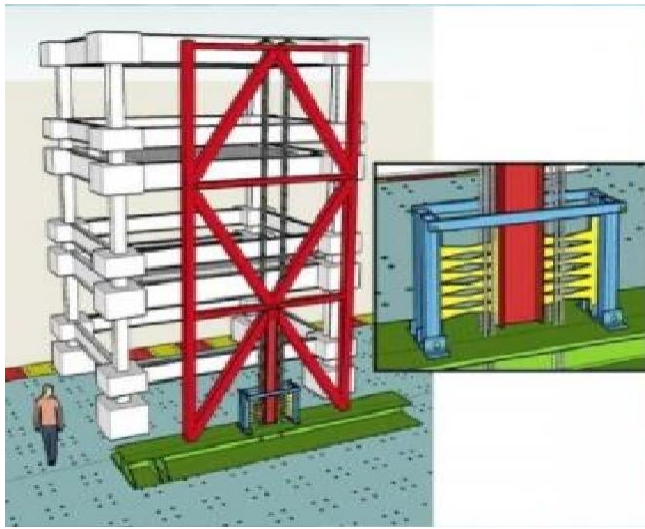

- Recently discovered technique of Japan
- It has found to be survived even in extreme earthquakes

CONCEPT

- When the quakes strikes the system dissipates energy in the building cores and exteriors
- The frames are free to rock up and down within fittings fixed at their bases

Building Characteristics for Eathquake Resistant

Structure

1. The quality of the soil

For designing a construction which will be earthquake resistant, the first thing to consider is the soil quality which will be able to withstand the pressure of the earthquake. The soil should have good flexibility and capability.

The soils which have coarse components like argillaceous sands, sandy gravels and consolidated soils. These soils are usually exposed to compact, hard and natural phenomena and are great for seismic resistant structures. Refrain from soils which are soft, sandy, clayey, loose as these are not appropriate for construction. Plastic soils in tend to lose their mechanical capacity and strength and become deformed after receiving water. As a result, they are in no way suitable for construction. Also refrain from steep slopes, dispersive clays and soils with organic fillings.

2. Foundation matters

The foundation of a building is one of the most important things to be kept into consideration, particularly while building a seismic resistant structure. In case there are unsuitable features in the soil, try replacing a section of the soil. Foundation is the key strength of a building. With the proper foundation, the structure can transmit the charges and weights to the nearby land and distribute them. This prevents damage to the main building. The structure, size and characteristic of the foundation will depend on the initial study of the terrain and the adjustments that need to be made. The best foundations are those which are larger than the structure which they will be supporting. Preferably the foundation should be made of reinforced steel and concrete.

3. Height of the structure

The numbers of storeys in the building and the height of the building will be a major factor in determining the load that will be borne by the foundation and the soil. Proper calculation should be done in this regard before making the design and planning of the structure. It has been seen that with proper planning and designing, buildings with many storeys have been safe during an earthquake and other natural calamities.

4. Distribution of load and symmetry

There should be symmetry in the structural designing of the building. This not only helps in proper distribution of the load over the foundation but also helps in maintaining a constant balance. Architect will make design plans which will make the structure attractive without compromising with the foundation and other important details.

5. Structural design

Structures should have the capacity of withstanding dynamic as well as static forces and be flexible enough to absorb them easily. This is applicable right from the foundation to enclosures, from load walls to delays etc. Buildings that lack flexibility and are rigid have high chances of breaking and cracking during earthquakes. If there is flexibility, the weight will be shifted accordingly and prevent the building from damage. With precise balance, it is possible to deal with an earthquake as compression, flexion and traction are absorbed and the building remains safe. It is also important to have greater numbers of structural elements right at the

base, on the first floor, on columns and girders, etc. This might be slightly expensive, but it can assure stability and resistance of buildings to seismic movements.

6. Quality of building materials

The quality of building materials used in the construction of the structure is an important thing to consider for establishing strength and toughness in a building. Materials which are certified help in absorbing the energy generated during an earthquake and prevent damage to the building in the best manner. The ideal combination is use of reinforced steel with concrete. This combination is not only strong and resistant, but extremely flexible at the same time. Also, the choice of the steel should be proper with exact calibres. Mechanical tests should be done on the materials to determine their authenticity and their strength for creating seismic resistant structures.

7. Maintenance post construction

After the construction of the structure, it is important that it should be maintained and taken care of well. After an earthquake, it is possible to understand how well the structure has been maintained. This is one of the basics of having a seismic proof building. Maintenance includes things like reinforcement of columns and gutters in case of detachments and separations, checking deck slabs, insulation restoration in walls, roofs and foundations, checking internal and external leakages etc.

Lateral Load Resisting Structure

During an earthquake, a wave propagates from the rock to the soil and then into the structure, creating a sway in the structure. The key to designing an earthquake-resistant structure is to build a ductile structure rather than a stiff structure. The extent of damage to a structure during an earthquake depends upon the distance of the epicentre from the structure horizontally as well as vertically below the ground. If the epicentre is closer to the surface, the damage tends to be larger in structures that are not resistant to earthquakes. It also depends on the type of soil. During earthquakes, certain soil such as sandy soil or deposited layers undergo soil liquefaction, causing greater damage to structures. Soil liquefaction is essentially when the soil bubbles, heaves or surges to the top surface under great

pressure. Generally during an earthquake, load bearing structures have brittle failure while well-designed reinforced cement concrete (RCC) structures have ductile failure. Earthquake-resistant design is essentially about ensuring that the damage to buildings during earthquakes is of an acceptable variety, with zero human loss and also that they occur at the right places and within acceptable ranges. All legally built structures are either load bearing or RCC structures. In load bearing structures, the brick walls are thick (between 9 inches to 1 foot) and carry the load to the foundation. It may have beams and the slab is typically made of concrete with steel reinforcement. RCC structures, referred to as framed structures, are made of concrete and steel and the load is carried by columns or shear walls to the foundation resting on concrete piles.

Load bearing structures were typically built prior to the 1970s, and have low resistance to earthquake. The bricks are stiff and have no way to either pull the structure in the direction opposite of the sway or be ductile enough to allow for small movement in the structure. Load bearing structures exhibit instantaneous failure and fall like a pack of cards. One way to avoid such catastrophic failure in load bearing structures is to create a disconnect between the foundation of the building and the rest of the above ground structure by using the base isolation method or levitating the building during earthquake from its base by having an air compressor fill air between the foundation and upper storeys. Such methods have been recently adopted in USA and Japan, but so far in India, the system is not very prevalent.

RCC framed buildings are typically about 30 ft to a few 100 ft long. Most two to fifteen storey buildings in India have stilt parking. There are no walls provided on the stilt floor creating larger flexibility in the ground structure. In an earthquake, such buildings sway like a reverse pendulum with rigidity being provided at the bottom and in such a case, the top portion of the building sways more than the bottom portion. Also, often the ground storey is a weak structure due to limited ability to carry horizontal forces. Such stilt parkings greatly reduce the earthquake resistance of a building and can fall during the earthquake. It is essential to have properly constructed in-fill walls so as to strengthen the buildings. Another method to reduce

failure during earthquakes is to design a strong core shear wall in seven to 20 storey RCC structures. Typically, this is designed in the elevator area. If the shear wall is designed as per relevant code, it can provide necessary stiffness to reduce excessive sway during the earthquake. For 20+ storey buildings, it necessary to provide a combination of vibration controlled systems to avoid catastrophic failures. This is typically done by providing proper core walls as well as by providing base isolation systems. Another way to reduce vibration in tall buildings is to provide tuned mass dampers and shock absorbers. Tuned mass dampers are essentially a pendulum with a specific viscous fluid which moves the building in the opposite direction of the structure's natural frequency, thereby avoiding catastrophic failures. Other types of energy dissipation devices such as friction dampers and yielding dampers are also adopted to reduce damage during earthquakes.

TYPES OF IRREGULARITIES

The Irregularity in the building structures may be due to irregular distributions in their mass, Strength and stiffness along the height of building. When such buildings are constructed in high Seismic zones, the analysis and design becomes more complicated. There are two types of Irregularities :-

1. Plan irregularities
2. Vertical irregularities.

Vertical irregularities are one of the major reasons of failures of structures during earthquakes. Vertical Irregularities are mainly of five types :-

- i) **Stiffness Irregularity** :- Under stiffness irregularity the stiffness of the members in a frame are not equal and they vary according to the floor height, modulus of elasticity of concrete and moment of inertia of that member.

ii) Mass Irregularity :- Mass irregularity shall be considered to exist where the seismic weight of any storey is more than 200 percent of that of its adjacent storeys. In case of roof irregularity need not be considered.



iii) Vertical Geometric Irregular :- A structure is considered to be vertical geometric irregular when the horizontal dimension of the lateral force resisting system in any storey is more than 200 percent of that in its adjacent storey. In case of roofs irregularity need not be considered.

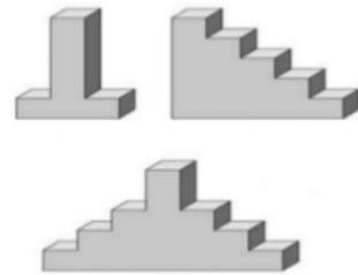

iv) In-Plan Discontinuity in Vertical Lateral Force -Resisting Element:-An in-plane offset of the lateral load resisting elements greater than the length of those elements.

v) Discontinuity in Capacity (Weak Storey):-A weak storey is one in which the storey strength is less than 80% of that in the storey above the total strength is the total strength of all seismic resisting elements sharing the storey shear for the direction under consideration.

Plan Irregularity:

Structures having one or more of the irregular features below listed shall be designated as having a plan irregularity.

i) Torsional Irregularity (to be considered when diaphragms are not flexible):

Torsional irregularity shall be considered to exist when the maximum storey drift, computed including accidental torsion, at one end of the structure transverse to an axis is more than 1.2 times the average of the storey drifts of the two ends of the structure.

ii) Reentrant Corners:

Plan configurations of a structure and its lateral force resisting system contain reentrant corners, where both projections of the structure beyond a reentrant corner are greater than 1.5% of the plan dimension of the structure in the given direction.

iii) Nonparallel Systems:

The vertical lateral load resisting elements are not parallel to or symmetric about major orthogonal axes of the lateral force-resisting system.

Alteration of existing Buildings:

Alteration can be defined as work intended to change the function or appearance of a place. Existing buildings often undergo alterations during their life to change, modify or improve their performance or the nature of their use.

Common examples of alterations include:

- Total or partial change of use.
- Extension.
- Partial demolition.
- Linking or separating spaces.
- Making or closing openings.
- Retrofitting a new a component or feature.
- Refurbishing an existing a component or feature.
- Renovating an existing component or feature.
- Repairing an existing component or feature.
- Maintenance.
- Decoration.

Safety Consideration During Additional Construction

● Hearing Protection

It is compulsory to wear hearing protection equipment near any equipment, tool or machinery which makes loud noises. As per standard practice if we are 2 foot away from somebody and we need to shout to talk, putting hearing protection is necessary.

● Respiratory Protection

Sometimes as voluntary respiration policy dust mask is supplied, any employee looking for additional comfort or safety while working with fiber glass, fire proofing, cleaning the floors or handling debris.

● Face shields

A full face shield should be worn along with safety glasses when working in a high debris, operating grinder or any spark producing activity or similar activities or when done on site. An approved welding shield is compulsory to wear during all welding operations.

- **Safety Harness**

The safety harness is an attachment between a fixed and mobile object and is usually fabricated from rope, cable and locking hardware. Full body safety harness to be used as a procedure for fall protecting system, ignorance can result in severe physical harm. Safety harnesses keep workers safe and are helpful in freeing their hands for work even while hanging on the side of a building.

- **Material Storage**

Material on the job site should be stored properly when not in use to prevent injury and wastage of materials. Ensure proper storage and good housekeeping. Proper storage can prevent the falls of the materials leading to material damage and accidents. Weight of the material stored should be within safe loading limits of the building floor. Keep the passageway always clear for walking of personal and prevent injuries. Always store the material away from traffic. Store material at least 6 feet away from the openings in the floor and 10 feet from the edge of the floor if the wall is not built on edge of floor.

- **Manual Material Handling**

The personnel should be aware of his weight lifting capacity and if required take the help of another person if required instead of taking all load himself and use proper lifting techniques. Always need to wear the safety equipment's while working on construction site.

- **Mechanical Material Handling**

Mechanical material handling also requires same amount of safety as in case of manual material handling. Equipment Operator needs to take care of the weight lifting capacity of the equipment like forklifts, cranes and other similar to avoid accidents. Ground personnel should be in machine operator's vision always and should be aware of the safety procedures while working around the heavy mechanical equipments.

Additional Strengthening Measures in Masonry Building:

- **Corner reinforcement**

Corner reinforcement are also called as torsional reinforcement. It shall be provided at corner of two way slab. The torsional moment are high near the corner therefore, torsional reinforcement is essential to prevent corner slab from lifting and prevents cracks. However, torsional reinforcing bar have three different requirement for three different types of corner C1, C2 and C3 as shown in fig given below:

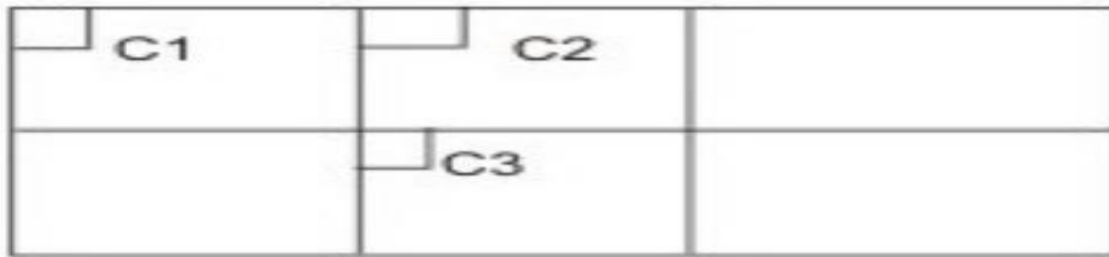

- **At corner C1** - The slab is discontinuous on both the sides, the torsion reinforcement shall consist of top and bottom bars each with layers of bar placed parallel to the sides of the slab and extending a minimum distance of one fifth of the shorter span from the edges. The amount of reinforcement in each of the four layers shall be 75 per cent of the area required for the maximum mid span moment in the slab.
- **At corner C2** - Contained by edges over one of which is continuous, the torsional reinforcement shall be half of the amount required for corner C1.
- **At Corner C3** - Contained by edges over both of which the slab is continuous, torsional reinforcement need not to be provided.

- **Lintel band**

It is a horizontal member which is placed at the top of the opening like door and window to support the portion of the unsupported wall above it continuously throughout the length of wall. It is the most important band.

Function

- ❖ The lintel band ties all the masonry walls together and create a support for adjoining masonry walls loaded along the weak direction from walls loaded in the strong direction.
- ❖ They also reduce the unsupported height of the walls, hence improves the stability of masonry walls in the weak direction.
- ❖ Lintel band also provides support to chhajja, and sill band support the load of the window frame.
- ❖ During an earthquake, bands sustain the shaking and hence minimize damage to load-bearing masonry building.
- ❖ They provide ductility and crack proof masonry building, as masonry buildings are as such brittle structure.

- **Roof Band**

These bands are mainly employed in buildings with roofs made of flat timber or CGI sheets. If the building roof is made of reinforced concrete slabs or brick roofs then there is no need of these bands. As R.C slabs itself behave as a horizontal band.

- **Gable Band**

A gable band is a horizontal member which is placed at the top of the ridge of the sloping slab to support the ends of the rafters and transferring loads to posts or gable end walls.

- **Plinth Band**

This type of horizontal bands is essential in those areas where the soil on which the building has to be constructed is weak. The soil will be soft with uneven properties. This problem is mainly found in soils found in hilly areas. This band is hence not necessary if we have a stronger soil and substructure.

- **Sill band**

It is a horizontal member which is placed at the bottom of the opening to support the load of the window frame. It is discontinued at the door opening.

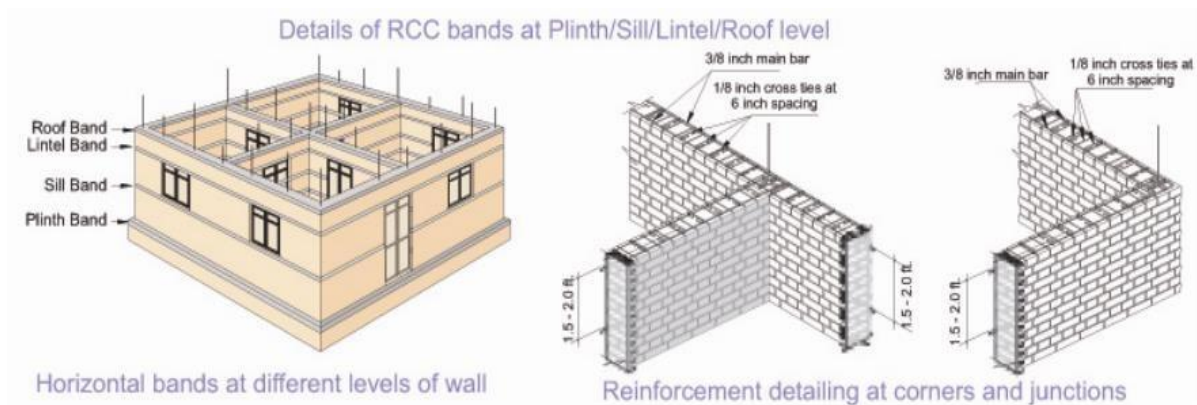

Retrofitting:

Retrofitting is the Science and Technology of strengthening the existing structures or structural elements to enhance their performance with new technology, features and components. Retrofitting of an existing reinforced concrete structure includes either repair, rehabilitation (or) strengthening terms.

Seismic Retrofitting

It is a collection of mitigation technique for Earthquake engineering. It is of utmost importance for historic monuments, areas prone to severe earthquakes and tall or expensive structures.

Seismic Retrofitting of Concrete Structures:

It is the modification of existing structures to make them more resistant to seismic activity, ground motion, or soil failure due to earthquakes. The retrofit techniques are also applicable for other natural hazards such as tropical cyclones, tornadoes, and severe winds from thunderstorms.

Seismic Retrofitting Techniques for Concrete Structures:

Seismic Retrofitting Techniques are required for concrete constructions which are vulnerable to damage and failures by seismic forces. In the past thirty years, moderate to severe earthquakes occurs around the world every year. Such events lead to damage to the concrete structures as well as failures. Thus the aim is to focus on a few specific procedures which may improve the practice for the evaluation of seismic vulnerability of existing reinforced concrete buildings of more importance and for their seismic retrofitting by means of various innovative techniques such as base isolation and mass reduction.

Need for Seismic Retrofitting:

- To ensure the safety and security of a building, employees, structure functionality, machinery and inventory
- Essential to reduce hazard and losses from non-structural elements.
- Predominantly concerned with structural improvement to reduce seismic hazard.
- Important buildings must be strengthened whose services are assumed to be essential just after an earthquake like hospitals.

Classification of Retrofitting Techniques:

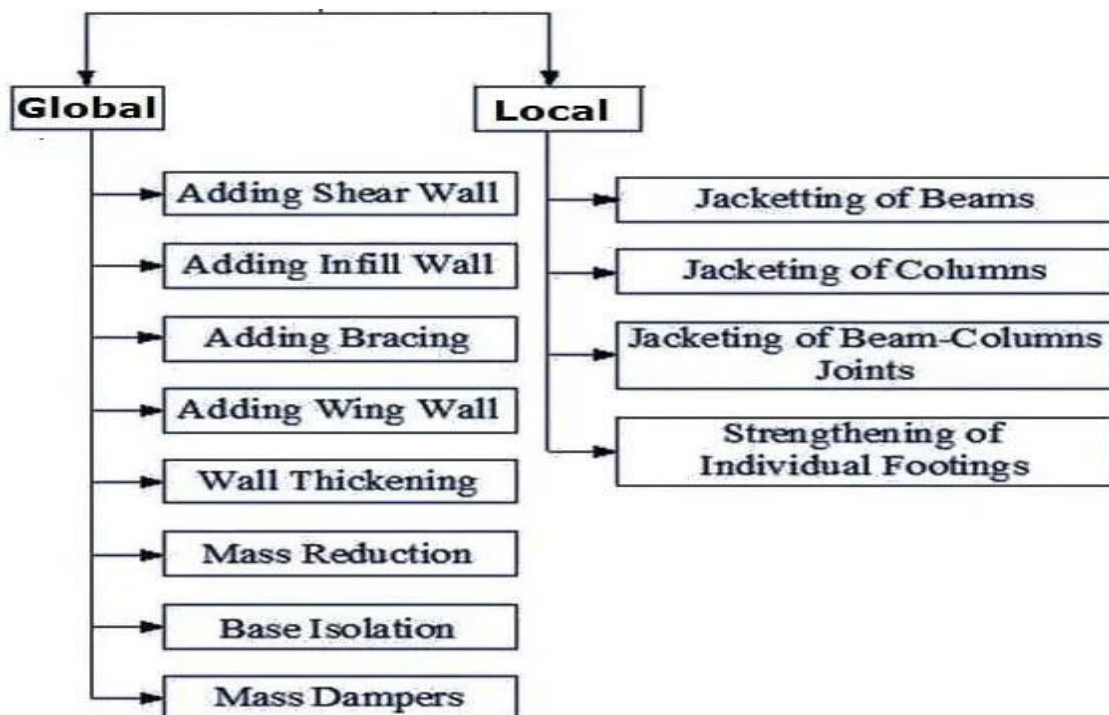

Adding Shear Walls:

- Frequently used for retrofitting of non-ductile reinforced concrete frame buildings.
- The added elements can be either cast in place or precast concrete elements.
- New elements preferably be placed at the exterior of the building.
- Not preferred in the interior of the structure to avoid interior mouldings.



Adding Steel Bracings

- An effective solution when large openings are required.

Potential advantages due to higher strength and stiffness, opening for natural light can be provided, amount of work is less since foundation cost may be minimized and adds much less weight to the existing structure

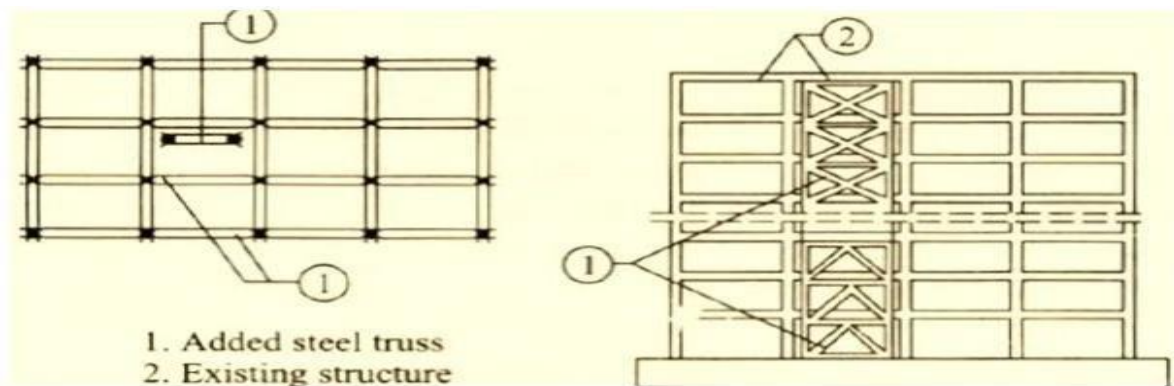

Wall Thickening :

The existing walls of a building are added certain thickness by adding bricks, concrete and steel aligned at certain places as reinforcement, such that the weight of wall increases and it can bear more vertical and horizontal loads, and also its designed under special conditions that the transverse loads does not cause sudden failure of the wall.



Base Isolation (or Seismic Isolation):

Isolation of superstructure from the foundation is known as base isolation. It is the most powerful tool for passive structural vibration control technique.

Advantages of Base Isolation

- Isolates Building from ground motion – Lesser seismic loads, hence lesser damage to the structure, -Minimal repair of superstructure.
- Building can remain serviceable throughout construction.
- Does not involve major intrusion upon existing superstructure

Disadvantages of Base Isolation

- Expensive
- Cannot be applied partially to structures unlike other retrofitting
- Challenging to implement in an efficient manner



Base Isolated Structures (a) Model Under Test, (b) Diagrammatical Representation

Mass Reduction Technique of Retrofitting:

This may be achieved, for instance, by removal of one or more storey's . In this case it is evident that the removal of the mass will lead to a decrease in the period, which will lead to an increase in the required strength.

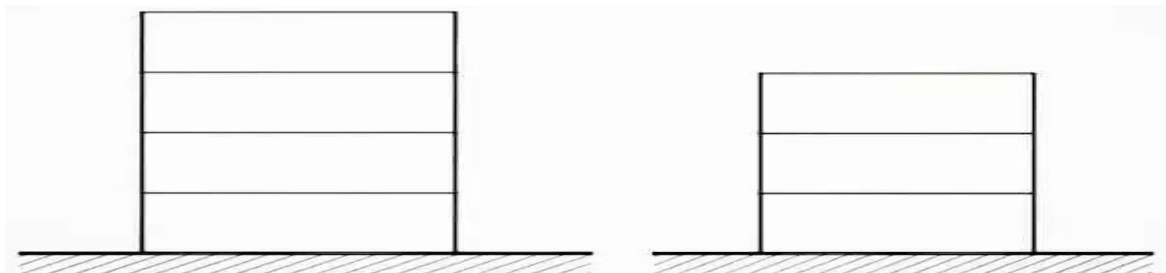

Seismic Retrofitting by Mass reduction (removal of Storey)

Adding Infill walls

- Masonry infills contribute significant lateral stiffness, strength, overall ductility and energy dissipation capacity.
- The structural load transfer mechanism is changed from frame action to predominant truss action.
- The frame columns now experience increased axial forces but with reduced bending moments and shear forces.
- When infills are non-uniformly placed in a building, cause soft storey effect, short-column effect, torsion and out-of-plane collapse.

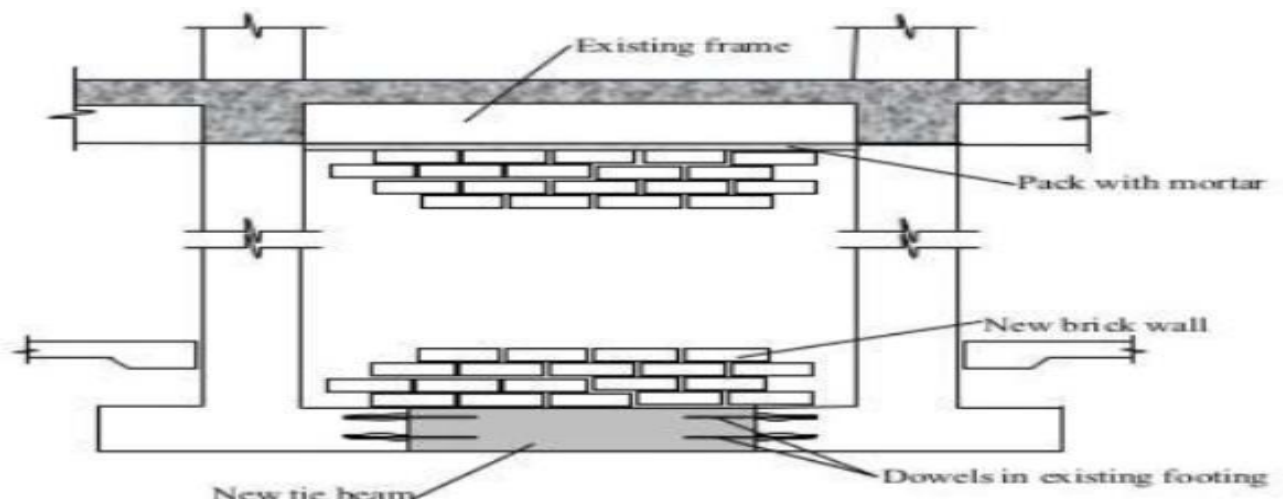

Adding Wing wall & Buttress

- To increase lateral strength, ductility and stiffness of structure.
- The wing wall are placed on the exterior side of an existing frame.



Mass Dampers

- Seismic dampers are used in place of structural elements, like diagonal braces, for controlling damage in structures.
- It partly absorbs the seismic energy and reduces the motion of buildings.
- Types of mass dampers:
 1. **Viscous dampers** (energy is absorbed by silicon-based fluid passing between piston-cylinder arrangement),
 2. **Friction dampers** (energy is absorbed by surfaces with friction between them rubbing against each other), and
 3. **Yielding dampers** (energy is absorbed by metallic components that yield).

Jacketing (Local Retrofitting Technique)

This is the most popular method for strengthening of building columns.

Types of Jacketing:

1. Steel jacket,
2. Reinforced Concrete jacket,
3. Fibre Reinforced Polymer Composite (FRPC) jacket

Purpose for jacketing:

- To increase concrete confinement
- To increase shear strength
- To increase flexural strength

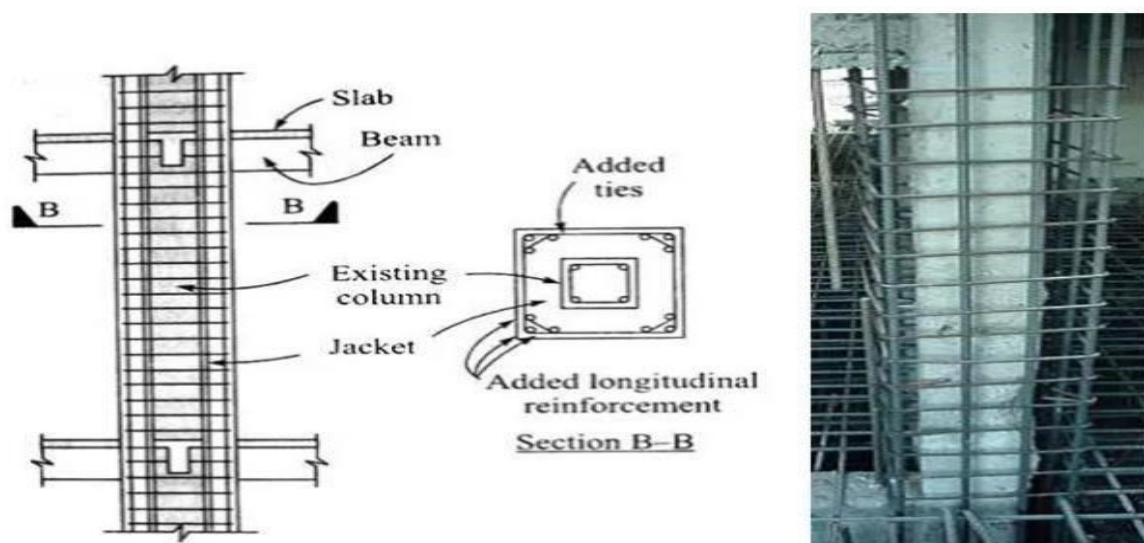

Column Jacketing

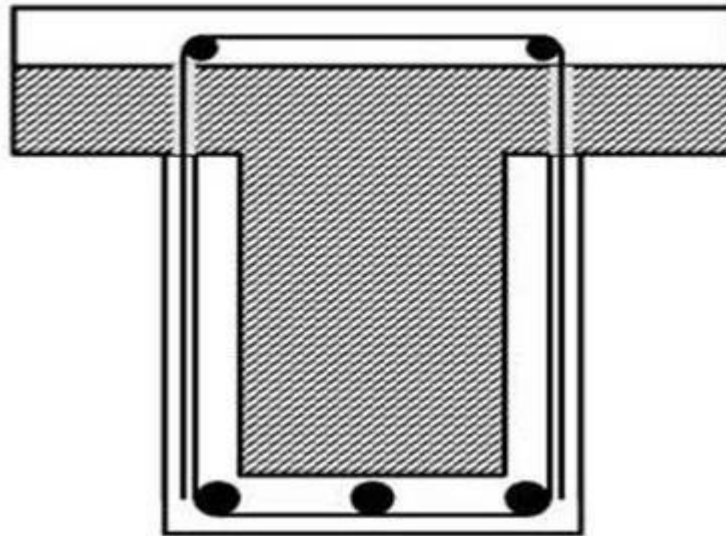

Beam Jacketing

Sources of Weakness in RC Frame Building

- Discontinuous load path/ interrupted load path/irregular load path
- Lack of deformation compatibility of structural members
- Quality of workmanship and poor quality of material

1. Discontinuous Load Path/interrupted load path/Irregular loadpath

- Every structure must have two load resisting systems vertical load resisting system for transferring the vertical load to ground (b) horizontal load resisting system for transferring the horizontal load to vertical load system
- It is imperative that the seismic forces should be properly collected by the horizontal framing system and transferred into vertical lateral resisting system
- Any discontinuity/irregularity in this load path or load transfer may cause one of the major contributions to structural damage during strong earthquakes
- In addition it must be ensured that each member both of horizontal or vertical load resisting system must be strong enough and not fail during an earthquake
- All the structural and non-structural elements must have sufficient strength and ductility and should be well connected to the structural system so that the load path must be complete and sufficiently strong

2. Structural Damage due of lack of Deformation

- Due to limited amount of ductility and the inability to redistribute load
- The most common regions of failure in an existing reinforced concrete frame are

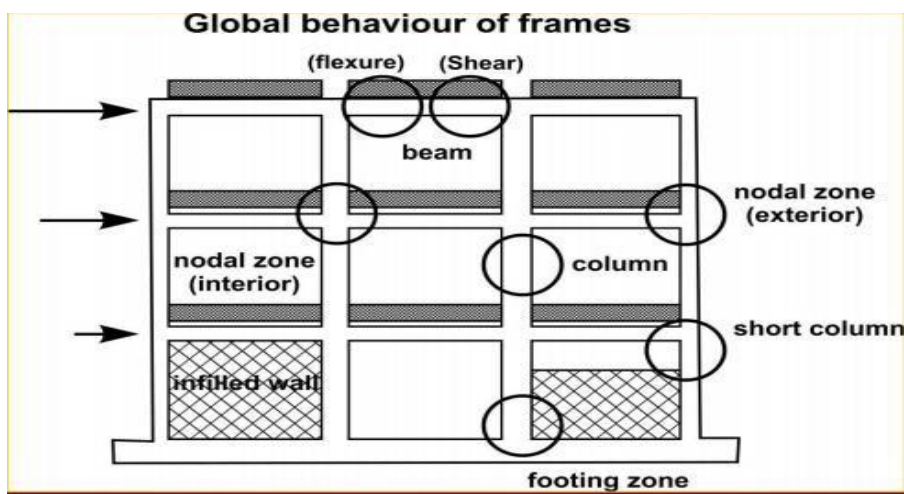

- **Columns**

- In reinforced concrete columns several interaction mechanism influences its lateral load behaviour.
- The main actions that concern are associated with axial, flexure, shear, and bond

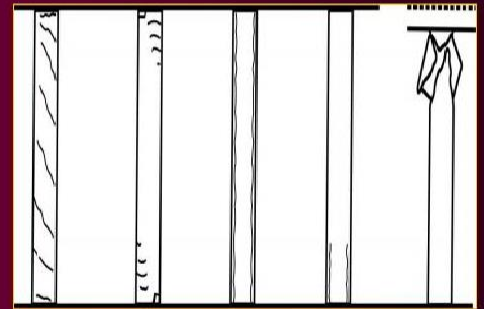
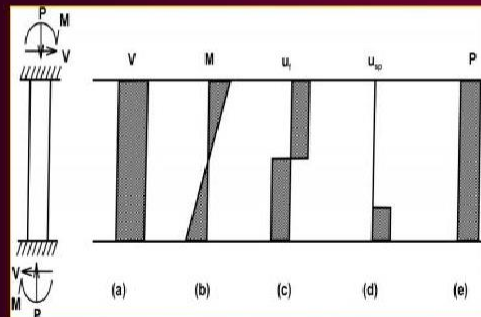

Action of concern force and its mode of failure in column

- **Beams**

- In reinforced concrete beams, the major problems exist at the right end, considering seismic forces left to right
- A brittle shear failure could occur due to superposing of shear forces caused by vertical loading and seismic loading

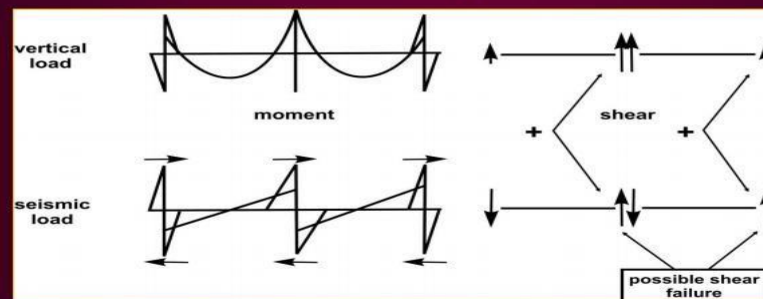

Behaviour of beams for vertical and seismic loading

3. Quality of Workmanship & Materials

- **There are numerous instances where faulty construction practices and lack of quality control have contributed to the damage**
- **The faulty construction practices may be like, lack of amount and detailing of reinforcement as per requirement of code particularly when the end of lateral reinforcement is not bent by 135 degrees as the code specified**
- **Many buildings have been damaged due to poor quality control of design material strength as specified, spalling of concrete by the corrosion of embedded reinforcing bars, porous concrete, age of concrete, proper maintenance etc.**

DISTRIBUTION SYSTEMS IN HIGH-RISE STRUCTURES

1. Direct Supply System
2. Direct Pumping Systems
3. Hydro-pneumatic Systems
4. Overhead Tank Distribution (Down Feed Arrangement)

1. DIRECT SUPPLY SYSTEM

- Useful when pressure is available round the clock at the topmost floor.
- The pressure may not be available so generally floors above 2nd or 3rd storey face shortfall of water pressure.

2. DIRECT PUMPING SYSTEMS

- Water is pumped directly into the distribution system without the aid of any over head tank except for flushing purposes.
- Pumps - controlled by pressure switch installed on the line.
- Useful in buildings where a certain amount of constant use of water occurs.
- The system requires a constant and reliable supply of power.
- Power failure – the breakdown of the water supply system.

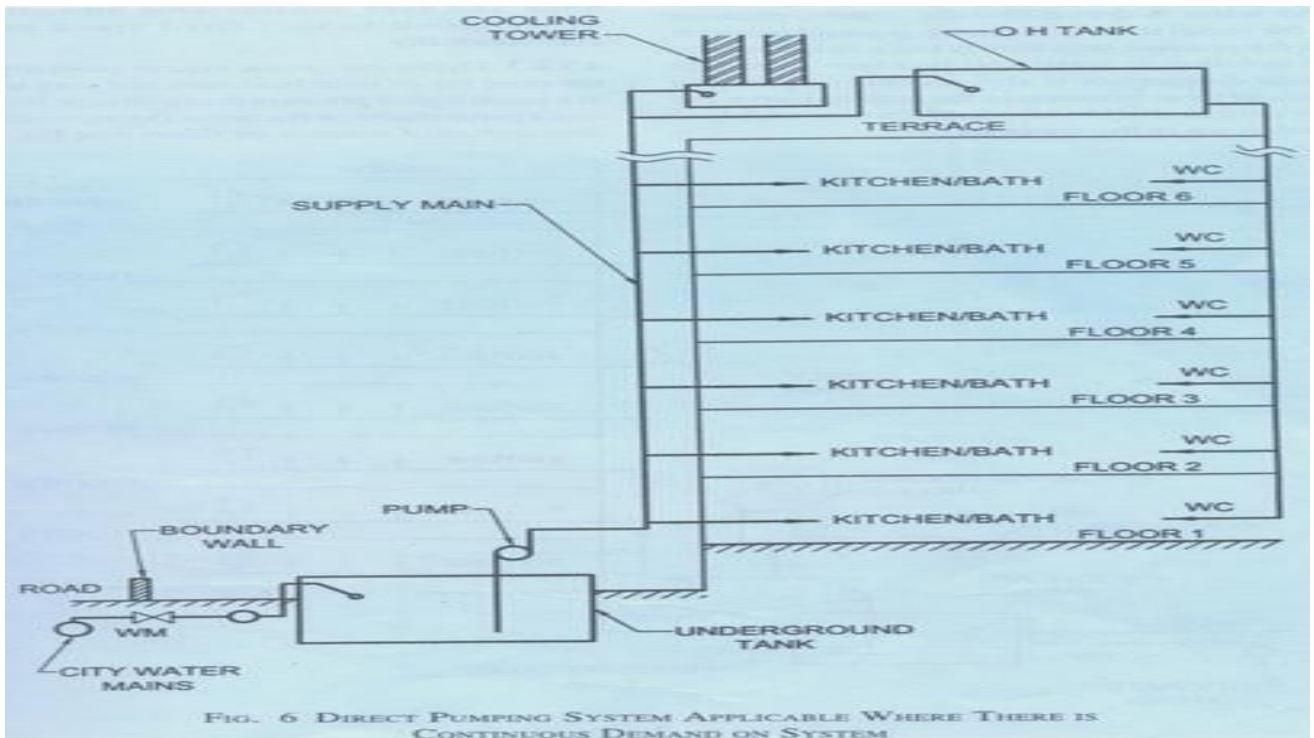

3. HYDRO-PNEUMATIC SYSTEM

- Variation of the direct pumping system.
- An airtight pressure vessel is installed on the line to regulate the operation of the pumps.
- The pressure switch installed in the pressure vessel/tank switches off after reaching the predetermined pressure when the operating pump is put to stop.
- An Air compressor is necessary to feed the water with air to maintain the air-water ratio.
- This system eliminates the need for an OHT and supplies water at a much higher pressure resulting in even distribution of water on all floors

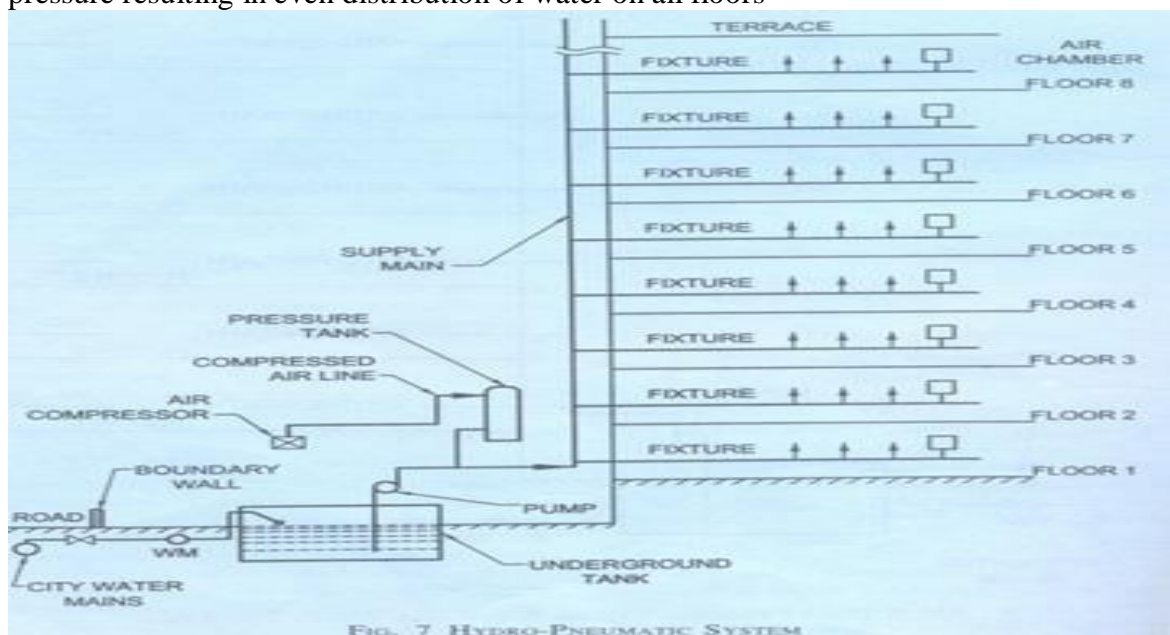

4. OVERHEAD TANK DISTRIBUTION

- The system comprises water to one or more OHT placed at the topmost location of the hydraulic zone.
- Water distribution- through pipes generally located on the terrace through gravity (down feed)

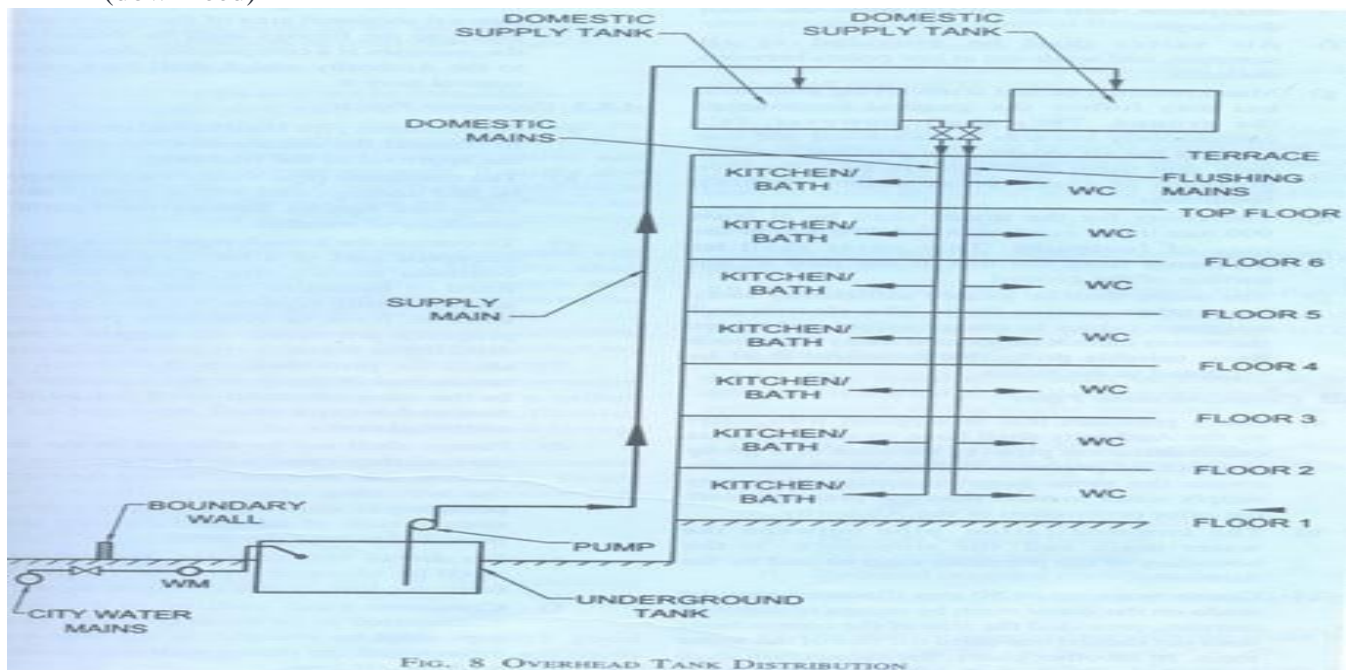

Hot Water Installation

Layout of pipelines -connection of hot water storage tank and collectors to be of shortest possible distance.

-Pipes should not be exposed to the weather if possible. (keep pipes inside the house where possible).

-All connections must be of good quality.

-Adequate spacing must be left for insulation (insulation thickness: 30 to 50 mm).

-Air valves and drainage valves must be in accessible places.

-Layout must allow complete drainage of the entire system.

Diameter-pipe diameter depends on different factors, such as:

- Consumption/time unit
- Total quantity/time
- Length

Earth Moving Machinery

1 EXCAVATION EQUIPMENTS

Following are the various equipments used for excavation purpose :

- (1) Bulldozers.
- (2) Scrapers
- (3) Graders
- (4) Power shovels.
- (5) Draglines
- (6) JCB
- (7) Hoses
- (8) Dredgers
- (9) Rippers.

1. Bulldozers

A bulldozer is very useful equipment on construction work for many purposes. Main functions (uses) of a bulldozer are :

- (1) Shallow excavations upto 300 mm deep either on level ground or side hill cutting.
- (2) Clearance of shrubs and small trees.
- (3) Clearance of tree by using raised mould blade as a pusher arm.
- (4) Clearing the floors of borrows and quarry pits.
- (5) Backfilling of trenches.
- (6) Spreading of earth fill.
- (7) Prepare pilot road through mountains and hard ground like rocky terrain.
- (8) Acting as a towing tractor.
- (9) Acting as a pusher to scraper machines.

Classification of Bulldozers

- (1) Depending upon control :
 - (a) Cable controlled
 - (b) Hydraulic controlled.
- (2) Depending upon mountings :
 - (a) Crawler-mounted
 - (b) Wheel-mounted.
- (3) Depending upon nature of blades :
 - (a) Front casting.
 - (b) Angle-dozer.

1. Depending upon control

Cable controlled bulldozer	Hydraulic controlled bulldozer
1. Blade is controlled by winding and unwinding of cable; passing over sheaves fitted at the back of blade.	1. Blade or push arm is controlled by piston rod.
2. Power for operation is taken from power control unit mounted on a tractor.	2. Power for operation is taken from hydraulic pump placed at the front of engine.
3. These can be lifted with only limited amount of forces, otherwise, there are chances of breaking cable.	3. These can be used for applying greater force smoothly.
4. Operation is complicated and requires more care.	4. Operation is easy and effective.
5. Maintenance is more.	5. Maintenance is very less.
6. Efficiency is less.	6. Efficiency is more.

2. Depending upon Mountings

Crawler-mounted bulldozer	Wheel-mounted bulldozer
1. It cannot be used for jobs, where high speed is required.	1. It can take high speed at the job.
2. When it moves on pavements, it causes damage to them.	2. It moves smoothly without causing any damage to pavements.
3. It is difficult to handle on steep gradients and sharp curves.	3. It is suitable on steep gradients and can work on sharp curves also.

3. Depending upon nature of Blades

Front casting dozer	Angle-dozer
1. Such dozers consist of a blade fixed perpendicular to the direction of travel.	1. Blade can be fixed at any angle with the direction of travel.
2. It will move the earth in forward direction by pushing it.	2. It will move the earth on sides i.e. right or left to the forward direction.
3. Used for levelling the heap of material.	3. Used for levelling the ground.

Power Shovels

A power shovel (also stripping shovel or front shovel or electric mining shovel or electric rope shovel) is a bucket-equipped machine, usually electrically powered, used for digging and loading earth or fragmented rock and for mineral extraction. Power shovels are a type of rope/cable excavator, where the digging arm is controlled and powered by winches and steel ropes, rather than hydraulics like in the more common hydraulic excavators. Basic parts of a power shovel include the track system, cabin, cables, rack, stick, boom foot-pin, saddle block, boom, boom point sheaves and bucket. The size of bucket varies from 0.73 to 53 cubic meters.

Uses

Power shovels are used principally for excavation and removal of overburden in open-cut mining operations; they may also be used for the loading of minerals, such as coal. They are the modern equivalent of steam shovels, and operate in a similar fashion.

Other uses of the power shovel include:

1. Close range work.
2. Digging very hard materials.
3. Removing large boulders.
4. Excavating material and loading trucks.
5. Various other types of jobs such as digging in gravel banks, in clay pits, cuts in support of road work, road-side berms, etc

Operations

The shovel operates using several main motions including:

- Hoisting - Pulling the bucket up through the bank of material being dug.
- Crowding - Moving the dipper handle in or out in order to control the depth of cut or to position for dumping.
- Swinging - Rotating the shovel between the dig site and dumping location.
- Propelling - Moving the shovel unit to different locations or dig positions.

Dragline

A dragline excavator is a piece of heavy equipment used in civil engineering and surface mining. Most crawler cranes, with an added winch drum on the front, can act as a dragline. These units (like other cranes) are designed to be dismantled and transported over the road on flatbed trailers which are used for road, port construction, pond and canal dredging, and as pile driving rigs.

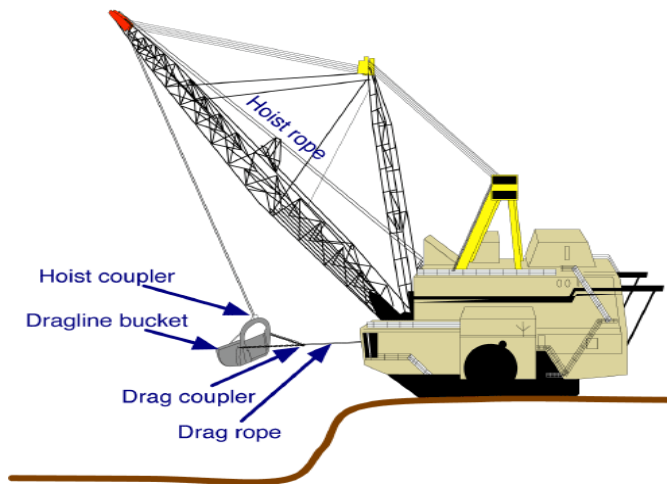

A large dragline system used in the open pit mining industry. A typical bucket has a volume ranging from 40 to 80 cubic yards (30 to 60 cubic metres), though extremely large buckets have ranged up to 168 cubic metres. The length of the boom ranges from 45 to 100 metres . In a single cycle, it can move up to 450 tonnes of material.

Most mining draglines are not diesel-powered like most other mining equipment. Their power consumption on order of several megawatts is so great that they have a direct connection to the high-voltage grid at voltages of between 6.6 and 22 kV. A typical dragline weighing 4000 to 6000 tons, with a 55-cubic-metre bucket, can use up to 6 megawatts during normal digging operations.

Limitations

- The boom height and boom length, of dragline which limits where the dragline can dump the waste material.
- Their dig depth, which is limited by the length of rope the dragline can utilize. Inherent with their construction, a dragline is most efficient excavating material below the level of their base. While a dragline can dig above itself, it does so inefficiently and is not suitable to load piled up material (as a rope shovel or wheel loader can).
- It has high extremely high capital cost.

Scraper

The scraper is a large piece of equipment which is used in mining, construction, agriculture and other earthmoving applications. The rear part has a vertically moveable hopper (also known as the bowl) with a sharp horizontal front edge. The hopper can be hydraulically lowered and raised. When the hopper is lowered, the front edge cuts into the soil or clay like a plane and fills the hopper. When the hopper is full (8 to 34 m³ or 10 to 44 cu yd heaped, depending on type) it is raised, and closed with a vertical blade (known as the apron). The scraper can transport its load to the fill area where the blade is raised, the back panel of the hopper, or the ejector, is hydraulically pushed forward and the load tumbles out. Then the empty scraper returns to the cut site and repeats the cycle.



Compaction

The main purpose of compaction is to prepare an area of soil or gravel for building over.

The main objectives are to:

- Increase shear strength and the bearing capacity.
- Increase stiffness which reduce future settlement.
- Decrease voids ratio and so permeability which reduces potential frost heave.

Different Types of Soil Compaction Equipments:

The soil compaction equipments can be divided into two groups:

1. Light soil compacting equipments
2. Heavy soil compacting equipments

1. Light Soil Compacting Equipments:

These equipments are used for soil compacting of small areas only and where the compacting effort needed is less. Below are light equipments for soil compaction:

- **Rammers:**

Rammers are used for compacting small areas by providing impact load to the soil. This equipment is light and can be hand or machine operated. The base size of rammers can be 15cm x 15cm or 20cm x 20cm or more. For machine operated rammers, the usual weight varies from 30kg to 10 tonnes (6 lbs to 22000 lbs). These hammers with 2- 3 tonnes (4400 to 6600 lbs) weights are allowed to free fall from a height of 1m to 2m (3ft to 7ft) on the soil for the compaction of rock fragments. Rammers are suitable for compacting cohesive soils as well as other soils. This machine in areas with difficulty in access.

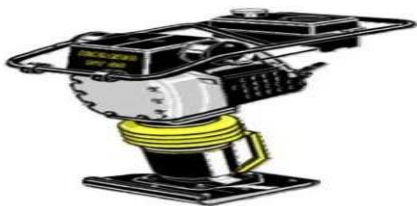

- **Vibrating Plate Compactors:**

Vibrating plate compactors are used for compaction of coarse soils with 4 to 8% fines. These equipments are used for small areas. The usual weights of these machines vary from 100 kg to 2 tonne with plate areas between 0.16 m² and 1.6 m².

- **Vibro Tampers:**

Vibro tampers is used for compaction of small areas in confined space. This machine is suitable for compaction of all types of soil by vibrations set up in a base plate through a spring activated by an engine driven reciprocating mechanism. They are usually manually guided and weigh between 50 and 100 kg .

2. Heavy Soil Compaction Equipments:

These compacting machines are used for large areas for use on different types of soils. The heavy compaction equipments are selected based on moisture content of soil and types of soil. Following are different types of these equipments:

A. Smooth Wheeled Rollers:

Smooth wheeled rollers are of two types:

- i) Static smooth wheeled rollers
- ii) Vibrating smooth wheeled rollers

i) Static smooth wheeled rollers

The most suitable soils for these roller type are well graded sand, gravel, crushed rock, asphalt etc. where crushing is required. These are used on soils which does not require great pressure for compaction. These rollers are generally used for finishing the upper surface of the soil. These roller are not used for compaction of uniform sands. The performance of smooth wheeled rollers depend on load per cm width it transfers to the soil and diameter of the drum. The load per cm width is derived from the gross weight of the drum. The smooth wheeled rollers consists of one large steel drum in front and two steel drums on the rear. The gross weight of these rollers is in the range of 8-10 tonnes (18000 to 22000 lbs). The other type of smooth wheel roller is called Tandem Roller, which weighs between 6-8 tonne (13000 to 18000 lbs). The performance of these rollers can be increased by increasing the increasing the weight of the drum by ballasting the inside of drums with wet sand or water. Steel sections can also be used to increase the load of the drum by mounting on the steel frame attached with axle. The desirable speed and number of passes for appropriate compaction of soil depends on the type of soil and varies from location to location. About 8 passes are adequate for compacting 20 cm layer. A speed of 3-6 kmph is considered appropriate for smooth wheel rollers.

ii) Vibrating smooth wheeled rollers

In case of vibrating smooth wheeled rollers, the drums are made to vibrate by employing rotating or reciprocating mass. These rollers are helpful from several considerations like:-

- Higher compaction level can be achieved with maximum work
- Compaction can be done up to greater depths
- Output is many times more than conventional rollers

B. Sheepsfoot Roller:

Sheepsfoot rollers are used for compacting fine grained soils such as heavy clays and silty clays. Sheepsfoot rollers are used for compaction of soils in dams, embankments, subgrade layers in pavements and rail road construction projects. Sheepsfoot rollers are of static and vibratory types. Vibratory types rollers are used for compaction of all fine grained soils and also soil with sand-gravel mixes. Generally this roller is used for compaction of subgrade layers in road and rail projects.

Sheepsfoot rollers consist of steel drums on which projecting lugs are fixed and can apply a pressure upto 14kg/sq cm or more. Different types of lugs are namely spindle shaped with widened base, prismatic and clubfoot type. The weight of drums can be increased as in the case of smooth wheeled rollers by ballasting with water, wet sand or by mounting steel sections. The efficiency of sheepsfoot rollers compaction can be achieved when lugs are gradual walkout of the roller lugs with successive coverage. The efficiency is affected by the pressure on the foot and coverage of ground obtained per pass. For required pressure and coverage of ground, the parameters such as gross weight of the roller, the area of each foot, the number of lugs in contact with the ground at any time and total number of feet per drum are considered. The compaction of soil is mainly due to foots penetrating and exerting pressure on the soil. The pressure is maximum when a foot is vertical.



C. Pneumatic Tyred Rollers:

Pneumatic tyred rollers are also called as rubber tyred rollers. These rollers are used for compaction of coarse grained soils with some fines. These rollers are least suitable for uniform coarse soils and rocks. Generally pneumatic tyred rollers are used in pavement subgrade works both earthwork and bituminous works. Pneumatic rollers have wheels on both axles. These wheels are staggered for compaction of soil layers with uniform pressure throughout the width of the roller. The factors which affects the degree of compaction are tyre inflation pressure and the area of the contact. The latest rollers have an arrangement to inflate the tyre to the desired pressure automatically. The total weight of the roller can be increased from 11.0 tonne to 25.0 tonne or more by ballasting with steel sections or other means.



D. Grid Rollers:

Grid rollers are used for compaction of weathered rocks, well graded coarse soils. These rollers are not suitable for clayey soils, silty clays and uniform soils. The main use of these rollers are in subgrade and sub-base in road constructions. These rollers have a cylindrical heavy steel surface consisting of a network of steel bars forming a grid with square holes. The weight of this roller can be increased by ballasting with concrete blocks. Typical weights vary between 5.5 tonnes net and 15 tonnes ballasted. Grid rollers provide high contact pressure but little kneading action and are suitable for compacting most coarse grained soils.



Factors Affecting Selection Of Construction Equipment

- **Scope of work to be carried out-** since the first concern is getting the job done, the time frame within which the work is required to be carried out, the specification of work and the methodology adopted will be of primary concern
- **Use of available-** for a work where full utilization of new equipment for its entire working life is not foreseen and its utilization on further project is uncertain it may be desirable to utilize existing old equipment even though its operation would be somewhat more expensive. The depreciation cost of new machine is likely to be high and this would rise the owning cost of the machine and consequently unit cost of work. Economic should be worked out.
- **Suitability for job conditions-**the equipment selected should suit the demands of the job conditions. Climate of region and working conditions should be kept in view while selecting the type of equipment.
- **Uniformity in type-** it is desirable to have minimum number of types so that there is uniformity in the type of equipment on a project. It is desirable to select common type of engine for different machine such as excavators, dump trucks, tractor and scrapers purchased on the projects.
- **Size of equipment** - while large size of machines are capable of giving large outputs on full load, the cost of production is usually greater than that of smaller units if worked out on part loads. Large size of equipment requires corresponding large size of matching equipment. And shutting down of one primary unit may result in making several other equipment idle. Transportation and shipment are usually difficult and expensive. However large equipment's are more sturdy and suitable for tough working conditions. It is also desirable to have equipment of same size on the project. If there are standbys the cost of smaller equipment as standby may be less than that of larger size of equipment.
- **Use of standard Equipments** - standard equipments are commonly manufactured and are commonly available and are moderately priced. The spare parts of standard equipment are easily available and less expensive. After the work is over, it is generally easier to dispose of standard equipment.
- **Unit cost production** - the economics is one of the most important considerations in selection of equipment. While working out owning cost all items of expenses, such as freight, packaging and forwarding, insurance, erection and commissioning etc. should be included with the price paid to supplier.
- **Country of origin** - when imports are unavoidable, it is preferable to import from a soft currency than from a hard currency area, if equipment quality is available.

- **Availability of spare parts** - Down time for want of necessary spare parts commonly accounts for long idle periods during working life of equipment, especially of imported equipment. Availability of spare parts at reasonable cost during the entire working life should be assured while selecting a particular type of equipment.

- **Versatility** – the equipment selected should be if possible, be capable of performing more than one function and should have feature of inter convertibility as far as possible.

- **Selection of manufacturer-** it is desirable to have equipment of the same manufacturer on a project as far as possible and to have minimum number of different makes of equipment. The quality of local dealers is also important.

- **Suitability of local labour** - available operators and technicians should be able to handle selected equipment.

Soil Reinforcing

Soil Reinforcing: The soil is very weak in tension and when it is loaded by any type of structures over it then it is not able to transfer all the forces arising in a structure. Hence it becomes necessary to reinforce the soil by using some reinforcing materials. is known as soil reinforcing.



3.4 SOIL REINFORCING TECHNIQUES

W-2009; S-2010

3.4.1 Necessity of Soil Reinforcing Techniques

S-2009

- The soil is very weak in tension and when it is loaded by any type of structures over it then it is not able to transfer all the forces arising in a structure. Hence it becomes necessary to reinforce the soil by using some reinforcing materials.
- The soil can be stabilized by introducing geotextiles and fabrics, which are made of synthetic materials, such as polyethylene, polyester, and nylon. The geotextile sheets are manufactured in different thickness ranging from 10 to 300 mils (1 mil = 25.4 μ).
- The width of the sheet can be upto 10 m. These are available in rolls of length upto about 600 m. Geotextiles are manufactured in different patterns, such as woven, non-woven, grid, and hybrid. The woven geotextiles are made from continuous mono-filaments of slit film fibers.

Soil Reinforcing Techniques

(1) Geotextiles as separators :

- Geotextiles are commonly used as separators between two layers of soils having a large difference in particle sizes to prevent migration of small-size particles into the voids of large-size particles.
- The main use as separators is in the construction of highways on clayey soils. As the particle size of granular base course of the highways is much larger than that of the subgrade (clayey soil in this case), it is the usual practice to provide an intervening soil layer of a soil containing grain-sizes intermediate between that of the subgrade and the base course to prevent migration of clay particles into the base course.
- Instead of the intervening soil layer, geotextile can be provided to serve the same purpose. The size of perforations should be according to the requirement. Thus, a geotextile sheet is used between the subgrade and the base course (Refer Fig. 3.26).

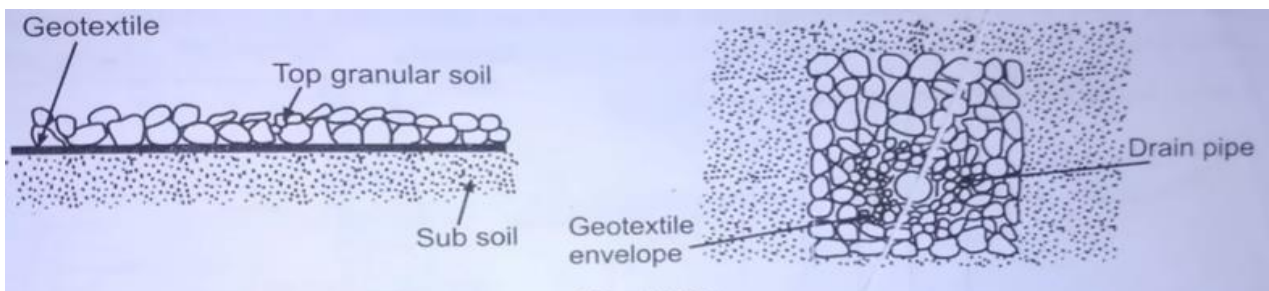

(2) Geotextile as filter :

- « It is the usual practice to provide a properly graded filter to prevent the movement of soil particles due to seepage forces. The filter is so designed, that the particle size of the filter is small enough to hold the protected material in place.
- If the filter material is not properly selected, the particles of the soil move into the pores of the filter and may prevent proper function of the drainage. It may also lead to piping.
- Geotextiles can be used as filters instead of conventional filter. When the silt-laden turbid water passes through the geotextiles, the silt particles are prevented from movement by the geotextile.
- The modification in the soil and void of the geotextiles occurs, and after some time an equilibrium stage is reached. For relatively thin geotextile sheet, most of the filtration occurs within the soil just upstream of the geotextile fabric. Fig 3.27 shows the use of geotextile as filter on the upstream and downstream of the core of the earth dam. It prevents the migration of the particles of the core into the shells.

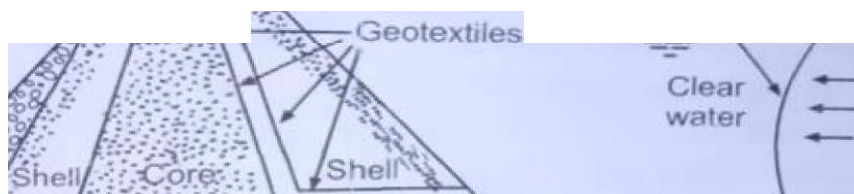

{3} Geogtextiles as drain :

- A drain is used to convey water safely from one place to another. Geotextiles are pervious, they themselves function as a drain. They have a relatively higher water-carrying capacity as compared to conventional drains.
- Drainage can be either perpendicular to the plane of the geotextile sheet. In the first case, it functions primarily as a filter. It acts as a water carrier, and a relatively bulky geotextile system is required. Fig. 3.28 shows a geotextile is used for drainage behind a retaining wall.

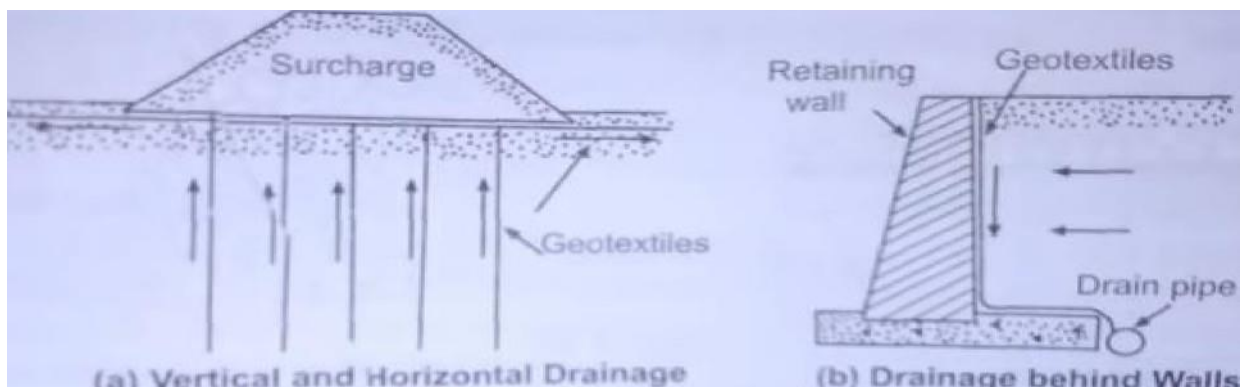

(4) Geotextile as reinforcement for strengthening soil :

- Geotextiles have a high tensile strength. These can be used to increase the load-carrying capacity of the soil.
- Geotextiles are used as reinforcement in the soil, which is poor in tension but good in compression. The action is somewhat similar to that of steel bars in a reinforced concrete slab.
- Geotextiles when used as reinforcement for soils have solved many construction problems on soft and compressible soils. Fig. 3.29 shows the reinforcement of an embankment with geotextiles.
- The geotextiles have been used in the construction of unpaved roads over soft soils. These are laid over the soil and the base course of the road is placed directly over it. When the vehicles pass over the road, the geotextile deforms and its strength is mobilized.

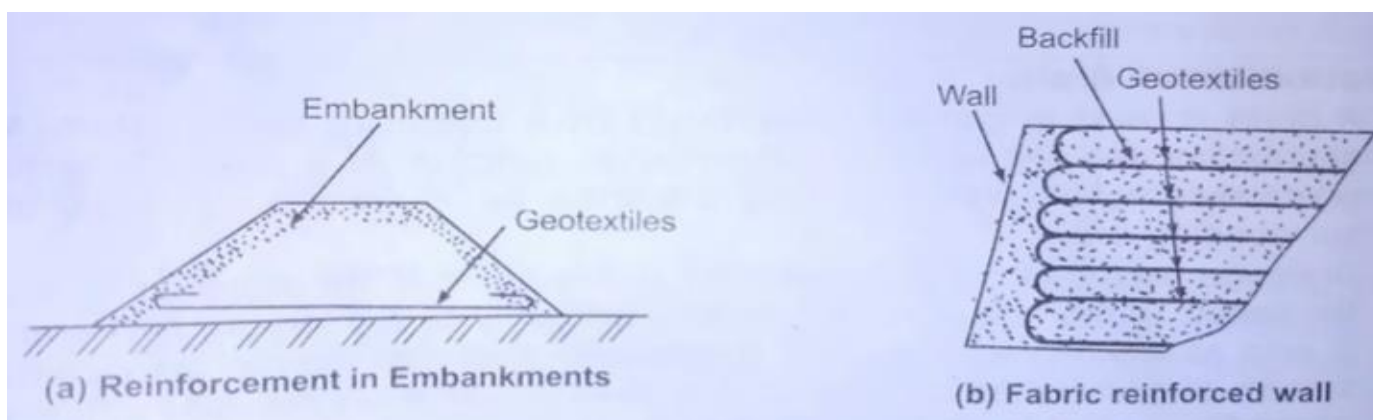

Geosynthetics

- These are synthetic products used to stabilize terrain. They are generally polymeric products used to solve civil engineering problems.
- This includes eight main product categories: geotextiles, geogrids, geonets, geomembranes, geosynthetic clay liners, geofoam, geocells and geocomposites.
- The polymeric nature of the products makes them suitable for use in the ground where high levels of durability are required. They can also be used in exposed applications. Geosynthetics are available in a wide range of forms and materials. These products have a wide range of applications and are currently used in many civil, geotechnical, transportation, geoenvironmental, hydraulic, and private development applications including roads, airfields, railroads, embankments, retaining structures, reservoirs, canals, dams, erosion control, sediment control, landfill liners, landfill covers, mining, aquaculture and agriculture.

1. Geotextiles

It is one of the two largest groups of geosynthetics. They are textiles consisting of synthetic fibers rather than natural ones such as cotton, wool, or silk. This makes them less susceptible to bio-degradation. These synthetic fibers are made into flexible, porous fabrics by standard weaving machinery or are matted together in a random non woven manner. Some are also

knitted. Geotextiles are porous to liquid flow across their manufactured plane and also within their thickness, but to a widely varying degree. There are at least 100 specific application areas for geotextiles that have been developed; however, the fabric always performs at least one of four discrete functions: separation, reinforcement, filtration, and/or drainage.

2. Geogrids

It represent a rapidly growing segment within geosynthetics. Rather than being a woven, nonwoven or knitted textile fabric, geogrids are polymers formed into a very open, grid like configuration, i.e., they have large apertures between individual ribs in the transverse and longitudinal directions. Geogrids are (a) either stretched in one, two or three directions for improved physical properties, (b) made on weaving or knitting machinery by standard textile manufacturing methods (c) by laser or ultrasonically bonding rods or straps together.

3. Geonets

Geonets and the related geospacers by some, constitute another specialized segment within the geosynthetics area. They are formed by a continuous extrusion of parallel sets of polymeric ribs at acute angles to one another. When the ribs are opened, relatively large apertures are formed into a netlike configuration. Two types are most common, either biplanar or triplanar. Alternatively many very different types of drainage cores are available. They consist of nubbed, dimpled or cusped polymer sheets, three-dimensional networks of stiff polymer fibers in different configurations and small drainage pipes or spacers within geotextiles.

4. Geomembranes

It represent the other largest group of geosynthetics. The materials themselves are relatively thin, impervious sheets of polymeric material used primarily for linings and covers of liquids or solid storage facilities. This includes all types of landfills, surface impoundments, canals, and other containment facilities. Thus the primary function is always containment as a liquid or vapour barrier or both. The range of applications, however, is great, and in addition to the environmental area, applications are rapidly growing in geotechnical, transportation, hydraulic, and private development engineering (such as aquaculture, agriculture, heap leach mining, etc.

Wire Mesh

- Functions of wire mesh are separating, screening, structuring, and shielding. The services or functions offered by a wire mesh or wire cloth is beneficial to the agricultural, industrial transportation, and mining sectors.
- Welded wire mesh is designed for building fencing and in other infrastructural purposes. It is a corrosion resistant wire mesh that is largely used in structural building. It is also available in different forms like rolls and panels for industrial uses.

Strengthening of Embankment :

Measures based on the above analyses, strengthening measures suggested are given below:

1. Upstream face

- On the breach portion on the southern side of reservoir, concrete lining with construction joints to be provided after preparation of surface and plate compaction.

2. Downstream face

- Erosion of the downstream slope to be prevented by providing grass turfing. Down stream surface should be properly maintained; all cuts (if any) filled on time and surface well grassed where turfing cannot grow on downstream slope of embankment, for proper growth of turfing selected soil layer may be provided or alternatively 300 mm thick hand placed riprap without filter layers may be provided

- Grass turfing shall consist of the furnishing and laying of live grass of perennial turf on downstream slope.

- Stone pitching with 1:3 cement mortar is to be provided at the slope in vicinity to an office building. Intermediate tie beams of size 200mmx300mm shall be provided at every 3m c/c in both directions.

3. Toe

- On the southern embankment near the breached area and on eastern embankment where there is a space restriction, 2m high RCC retaining wall/Gabion wall is recommended at the toe.

- Toe drains are to be provided all along the periphery details.

4. Top of embankments

- Cracks of the top layer shall be filled with bentonite slurry with 50mm dia. 2m long holes at 3m spacing

- Compaction using plate compactors with adequate sprinkling of water after soil stabilization

- Interlocking pavement blocks to be provided with underlying 75mm thick sand layer and 100 thick Granular sub base (GSB)

- Top level of all embankments to be maintained uniformly at same level before pavement work commences .

5. Mid embankments

- Loose materials in the breached portion shall be removed up to hard soil and compacted using plate compactor. Sides of the breached portion to be trimmed to a slope of 1V:3H and to be protected using 125 thick concrete lining on the sides and bottom to avoid further erosion. If unprotected, this will lead to uncontrolled seepage along the direction of the embankment on northern side, which may further breach.

6. Freeboard

- Freeboard of 1.5m is to be provided for the reservoir during its operation at Full Reservoir Level (FRL) • A parapet wall of height 0.5 m is also proposed on the inner periphery of the embankment.

Soil Reinforcement Techniques

Soil reinforcement techniques can be divided into two major categories

1. In situ soil reinforcement

In the insitu reinforcement technique the reinforcement is placed in an undisturbed soil to form a reinforced soil structure. This includes the technique of soil nailing and soil dowelling. The reinforcement used for in situ structures is usually linear owing to the method of installation.

2. Constructed soil reinforcement

The facing usually comprises of prefabricated concrete or steel panels joined together by an interlocking arrangement. The soil used as backfill in such cases is granular soil with less than 15% fines to enable development of large friction between the reinforcement and soil. The most often used reinforcement is steel strips since they have large tensile strength as well as low extensibility. Construction takes place from bottom upwards and the reinforcement is placed sequentially as layers of soil are compacted, one after the other. The constructed soil reinforcement technique describes the technique where the reinforcement is placed at the same time as an imported and remoulded soil. Such techniques are often called as bottom up process as they involve the placement of a fill and reinforcement simultaneously, these include structures such as reinforced soil embankments and bridge abutments. The reinforcement used for the constructed category is in the form of strips, mats or grids.

Electrical Service requirements in High Rise Buildings:

The main installations for electric service are heating, ventilation, air conditioning and refrigeration, fire protection, protection against burglary, building control system and power distribution. In modern planning, the demands on a high rise building are not simply split up among the individual installations, but have to be coordinated. An optimum solution is created from the networking of the individual requirements. The planning requirements for an energy management system for the high rise building are also integrated. Even if a building is used for 50 years or more, the significantly shorter cycles of changes in the usage, such as hotel refurbishment, new shop owners, new IT equipment in the computer centre and changes to the offices and in the life cycle of equipment and facilities require useful, long-term preliminary planning. This application manual provides an overview of the electrical design installations of a high rise building that are important for the electrical power distribution and describes the basic and preliminary planning of the power distribution for an example.

In the modern world of today and tomorrow, buildings shall provide maximum safety, consume few resources during construction and operation and be flexibly adaptable to future requirements. The intelligent integration of all building services installations offers an optimum to be attained for safety, energy efficiency environmental compatibility and flexibility in combination with maximum comfort.

A tailored total solution for electric power distribution, building automation, fire protection and security systems create the added value the client expects.