



GOVERNMENT POLYTECHNIC, DHENKANAL

Programme: Diploma in Mechanical Engineering

Course: Engineering Materials (Theory)

Course Instructor's Name: Biswajit Mishra

[E-mail- biswajeet.mishra@gmail.com](mailto:biswajeet.mishra@gmail.com)

Contact no- 9178182635

Semester: 3RD

Engineering materials and their properties

Introduction

- Material science and engineering plays a vital role in this modern age of science and technology. Various kinds of materials are used in industry, housing, agriculture, transportation, etc. to meet the plant and individual requirements.
- The knowledge of materials and their properties is of great importance for a design engineer
- A design engineer must be familiar with the effects which the manufacturing processes and heat treatment have on the properties of the materials

The engineering materials are mainly classified as

- Metals and their alloys, such as iron, steel, copper, aluminium etc.
- Non-metals such as glass, rubber, plastic etc.

Metals may further be classified as-

- Ferrous metals -

The ferrous metals are those which have the iron as their main constituent, such as cast iron, wrought iron etc.

- Non-ferrous metals .

The non-ferrous metals are those which have metal other than iron as their main constituent, such as copper, aluminium, brass, tin, zinc etc.

Physical properties

- Physical properties are employed to describe the response of a material to imposed stimuli under conditions in which external forces are not concerned.

- Physical properties include .

- a) Dimensions,
- b) Appearance,
- c) Colour
- d) Density,
- e) Melting point,
- f) Porosity,
- g) structure, etc.

Dimensions

Dimensions of a material implies it's size(length,breadth,width,diameter, etc.) and shape(square,circular,channel,anglesection, etc.)

Appearance

- Metals themselves have got different appearances e.g., aluminium is a silvery white metal

where as copper appears brownish red.

- Appearance include lusture, colour and finish of a material.

Lusture is the ability of a material to reflect light when finely polished. It is the brightness of a surface.

Colour

- The colour of the material is very helpful in identification of a metal. The colour of a metal depends upon the wavelength of the light that the material can absorb.

Density

- The density is the weight of unit volume of a material expressed in metric units.

- Density depends to some extent on the

- a) Purity of material
- b) Pour volume
- c) Treatment, the material has received.

Density helps differentiating between light and heavy metals even if they have same shape and any outer protective coating.

Melting point

- Melting point of a material is that temperature at which the solid metals change into molten state.

- One metal can be distinguished from the other on the basis of its melting point.

Porosity

- A metal is said to be porous if it has pores within it.
- Pores can absorb lubricant as in a sintered self-lubricating bearing.
- It is the ratio of total pore volume to bulk volume

Structure

- It means geometric relationships of material components.
- It also implies the arrangement of internal components of matter(electron structure, crystal structure, and micro structure)

Chemical properties

- A study of chemical properties of materials is necessary because most of engineering materials when they come in contact with other substances with which they can react, tend to suffer from chemical deterioration.

The chemical properties describe the combining tendencies, corrosion characteristics, reactivity, solubilities, etc.of a substance.

- Some of the chemical properties are

1. corrosion resistance
2. chemical composition
3. acidity or alkalinity

Corrosion

- It is the deterioration of a material by chemical reaction with its environment.
- Corrosion degrades material properties and reduces economic value of the material.

- Corrosion attacks metals as well as non-metals. Corrosion of concrete by sulphates in soils is a common problem

Performance requirement

- The material of which a part is composed must be capable of embodying or performing a part's function without failure.

for example – a component part to be used in a furnace must be of that material which can withstand high temperatures.

- While it is not always possible to assign quantitative values to these functional requirements, they must be related as precisely as possible to specified values of most closely applicable mechanical, physical, electrical or thermal properties.

Material's reliability

- Reliability is the degree of probability that a product, and the material of which it is made, will remain stable enough to function in service for the intended life of the product without failure.
- A material if it corrodes under certain conditions, then, it is neither stable nor reliable for those conditions.

Safety

A material must safely perform its function, otherwise, the failure of the product made out of it may be catastrophic in air-planes and high pressure systems. As another example, materials that gives off spark when struck are safety hazards in a coal mine.

Ferrous Materials and alloys

Characteristics of ferrous materials:

- Ferrous materials are metals or metal alloys that contain the iron as a base material.
- Steel is a ferrous alloy, and there are a number of other alloys that contain iron.
- Ferrous metals are good conductors of heat and electricity.
- Metal alloys have high resistance to shear, torque and deformation.
- The thermal conductivity of metal is useful for containers to heat materials over a flame.

The principal disadvantages of many ferrous alloys is their susceptibility to corrosion.

Application:

- Due to the strength and resilience of metals they are frequently used in high-rise building and bridge construction, most vehicles, many appliances, tools, pipes, non-illuminated signs and railroad tracks.
- Corrosion resistance property makes them useful in food processing plants, e.g., steel.
- Cast iron is strong but brittle, and its compressive strength is very high. So used in castings, manhole covers, engine body, machine base etc.
- Mild steel is soft, ductile and has high tensile strength. It is used in general metal products like structural, workshop, household furniture etc.
- Carbon steels are used for cutting tools due to their hardness, strength and corrosion resistance properties.

Classification:

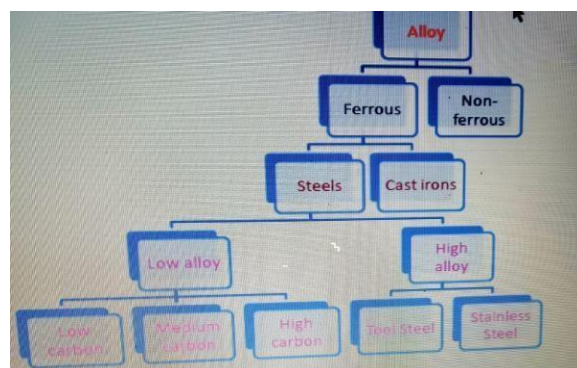

Steel-It is an alloy of iron and carbon in which carbon content is upto 2%.

It may contain other alloying elements.

Cast iron-In cast iron carbon content is 2% to 6.67%

Lower melting point (about 300 °C lower than pure iron) due to presence of eutectic point at 1153

°C and more carbon content.

Types of cast iron: grey, white, nodular, malleable and compacted graphite.

Low carbon steel-Carbon content in the range of 0 – 0.3%.

Most abundant grade of steel is low carbon steel (greatest quantity produced; and least expensive).

Not responsive to heat treatment; cold working needed to improve the strength.

It has good weldability and machinability

Medium carbon steel-Carbon content in the range of 0.3 – 0.8%.

It can be heat treated - austenitizing, quenching and then tempering.

Most often used in tempered condition – tempered martensite

Medium carbon steels have low hardenability

Addition of Cr, Ni, Mo improves the heat treating capacity

Heat treated alloys are stronger but have lower ductility

Typical applications – Railway wheels and tracks, gears, crankshafts.

High carbon steel-High carbon steels – Carbon content 0.8 – 2%

High C content provides high hardness and strength.

Hardest and least ductile.

Used in hardened and tempered condition

Strong carbide formers like Cr, V, W are added as alloying elements to form carbides of these

metals.

Used as tool and die steels owing to the high hardness and wear resistance property

Tool steel- Tool steel refers to a variety of carbon and alloy steels that are particularly well-suited to be made into tools. Their suitability comes from their distinctive hardness, resistance to abrasion, their ability to hold a cutting edge, and/or their resistance to deformation at elevated temperatures. Tool steel is generally used in a heat-treated state. Many high carbon tool steels are also more resistant to corrosion due to their higher ratios of elements such as vanadium. With a carbon content between 0.7% and 1.5%, tool steels are manufactured under carefully controlled conditions to produce the required quality.

Stainless steel-Stainless steel does not readily corrode, rust or stain with water as ordinary steel does, but despite the name it is not fully stain-proof, most notably under low-oxygen, high-salinity, or poor-circulation environments. There are different grades and surface finishes of stainless steel to suit the environment the alloy must endure. Stainless steel is used where both the properties of steel and corrosion resistance are required. Stainless steel differs from carbon steel by the amount of chromium present.

Plain Carbon Steel

Plain Carbon Steel is an alloy of iron and carbon with carbon content up to 1.5% although other elements such as Silicon, Manganese may be present. The properties of carbon steel are mainly due to its carbon content.

Carbon Steel is classified into

- i) Low carbon steel or Mild steel
- ii) Medium carbon steel
- iii) High carbon steel

Low carbon steel or Mild steel:

Low carbon steel or mild steel is further classified into three types basing on their composition i.e percentage of carbon.

- a) Dead mild steel or mild steel containing 0.05 to 0.15% of carbon.
- b) Mild steel containing 0.15 to 0.2% of carbon.
- c) Mild steel containing 0.2 to 0.3% of carbon.

Application of Mild Steel:

- i) Dead mild steel is used for making steel wire, sheet, rivets, screws, pipe, nail, chain, etc.
- ii) Mild steel containing 0.15 to 0.2% carbon is used for making camshafts, sheets, strips for blades, welded tubing, forgings, drag lines, etc.
- iii) Mild steel containing 0.2 to 0.3% carbon is used for making valves, gears, crank shafts, connecting rods, railway axles, fish plates and small forgings, etc.

Medium Carbon Steel

Steel containing 0.3 to 0.7% carbon is known as Medium carbon steel.

Medium carbon steel are of three categories.

- i) Steel containing 0.35 to 0.45% carbon is used for connecting rod, wires & rod, spring clips, gear shaft, key stock, shafts & brakes lever, axle, small & medium forgings, etc.
- ii) Steel containing 0.45 to 0.55% carbon is used for railway coach axles, axles & crank pins on heavy machines, splines shafts, crank shafts, etc.
- iii) Steel containing 0.6 to 0.7% carbon is used for drop forging die & die blocks, clutch discs, plate punches, set screws, valve springs, cushion ring, thrust washers, etc.

High carbon steel

Steel containing 0.7 to 0.1.5% carbon is known as high carbon steel.

Uses

- i) Steel containing 0.7 to 0.8% carbon is used for making cold chisels, wrenches, jaws for vice, pneumatic drill bits, wheels for railway service, wire for structural work, shear blades, automatic clutch disc, hacksaws, etc.

Tool Steel:

Tool steel may be defined as special steel which are used to form, cut or otherwise change the shape of a material into finished or semi-finished product.

Properties of Tool steel:

- i) Slight change of form during hardening.
- ii) Little risk of cracking during hardening.
- iii) Good toughness

- iv) Good wear resistance
- v) Very good machinability
- vi) A definite cooling rate during hardening
- vii) A definite hardening temperature
- viii) Resistance to de-carburization
- ix) Resistance to softening on heating

Classification of Tool steel:

The Joint Industry Conference, U.S.A. has classified tool steel as follows:

Symbol Meaning

- T W-High speed steel
- M Mo-High speed steel
- D High C, high Cr steel
- A Air hardening steel
- O Oil hardening steel
- W Water hardening steel
- H Hot work steel
- S Shock resistance steel

Composition of Tool Steel:

- 1) W-High speed steel
 - T₁: C 0.7 Cr 4 V 1 W 18
 - T₄: C 0.75 Cr 4 V 1 W 18 Co 5
 - T₆: C 0.8 Cr 4.5 V 1.5 W 20 Co 12
- 2) Mo-High speed steel
 - M₁: C 0.8 Cr 4 V 1 W 1.5 Mo 8
 - M₆: C 0.8 Cr 4 V 1.5 W 4 Mo 5 Co 12
- 3) High C, high Cr steel
 - D₂: C 1.5 Cr 12 Mo 1
 - D₅: C 1.5 Cr 12 Mo 1 Co 3
 - D₇: C 2.35 Cr 12 V 4 Mo 1
- 4) Air hardening steel
 - A₂: C 1 Cr 5 Mo 1
 - A₇: C 2.25 Cr 5.25 V 4.75 W 11 Mo 1
 - A₉: C 0.5 Cr 5 Ni 1.5 V 1 Mo 1.4
- 5) Oil hardening steel
 - O₁: C 0.9 Mn 1 Cr 0.5 W 0.5
 - O₂: C 1.45 Si 1 Mo 0.25
- 6) Water hardening steel
 - W₂: C 0.6/1.4 V 0.25
 - W₅: C 1.1 Cr 0.5
- 7) Hot work steel
 - H₁₀: C 0.4 Cr 3.25 V 0.4 Mo 2.5
 - H₁₂: C 0.35 Cr 5 V 0.4 W 1.5 Mo 1.5
- 8) Shock resistance steel
 - S₁: C 0.5 Cr 1.5 W 2.5
 - S₂: C 0.5 Si 1 Mo 0.4
 - S₅: C 0.55 Mn 0.8 Si 2 Mo 0.4
 - S₇: C 0.5 Cr 3.25 Mo 1.4

Stainless Steel:

When 11.5% or more chromium is added to iron, a fine film of chromium oxide forms spontaneously on the surfaces. The film acts as a barrier to retard further oxidation, rust or corrosion. As this steel cannot be stained easily, it is called stainless steel. The stainless steel basing on their micro-structure can be grouped in to three metallurgical classes such as Austenitic stainless steel, Ferritic stainless steel & Martensitic stainless steel.

Austenitic Stainless Steel:

Properties:

- 1) They possess austenitic structure at room temperature.
- 2) They possess the highest corrosion resistance of all the stainless steels.
- 3) They possess greatest strength and scale resistance at high temperature.
- 4) They retain ductility at temperature approaching absolute zero.
- 5) They are non-magnetic.

Composition:

C 0.03 to 0.25% Mn 2 to 10% Si 1 to 2%
 Cr 16 to 26% Ni 3.5 to 22%
 P & S Normal Mo & Ti in some cases

Uses:

- 1) Aircraft industry (Engine parts)
- 2) Chemical processing (heat exchangers)
- 3) Food processing (Kettles, tanks)
- 4) Household items (cooking utensils)
- 5) Dairy industries (milk cans)
- 6) Transportation industry (Trailers & railways cars)

Ferritic stainless steel:

Properties:

- 1) They possess a microstructure which is primarily ferritic.
- 2) They are magnetic & have good ductility
- 3) They do not work harden to any appreciable degree.
- 4) They are more corrosion resistant than martensitic steel.
- 5) They develop their maximum softness, ductility & corrosion resistance in the annealed condition.

Composition:

C 0.08 to 0.20% Si 1% Mn 1 to 1.5% Cr 11 to 27%

Uses:

- 1) Lining for petroleum industry.
- 2) Heating elements for furnaces.
- 3) Interior decorative work.
- 4) Screws & fittings.
- 5) Oil burner parts.

Martensitic stainless steel:

Properties:

- 1) They possess martensitic microstructure.
- 2) They are magnetic in all condition & possess the best thermal conductivity of the stainless types.

- 3) Hardness, ductility & ability to hold an edge are characteristics of martensitic steels.
- 4) They can be cold worked without difficulty, especially with low carbon content, can be machined satisfactorily.
- 5) They have good toughness.
- 6) They have good corrosion resistance to weather and to some chemicals.
- 7) They are easily hot worked.

Composition:

C 0.15 to 1.2% Si 1% Mn 1% Cr 11.5 to 18%

Uses:

- 1) Pumps & valve parts
- 2) Rules & tapes
- 3) Turbine buckets
- 4) Surgical instruments, etc.

Effect of Alloying Elements:

Chromium: It joins with carbon to form chromium carbide, thus adds to depth hardenability with improved resistance to abrasion & wear.

Manganese:

- 1) It contributes markedly to strength and hardness.
- 2) It counteracts brittleness from sulphur.
- 3) Lowers both ductility & weldability if it is present in high percentage with high carbon content in steel.

Nickel: It

- 1) increases toughness & resistance to impact.
- 2) lessens distortion in quenching.
- 3) Lowers the critical temperatures of steel & widens the range of successful heat treatment.
- 4) strengthens steels.
- 5) Renders high-chromium iron alloys austenitic.
- 6) does not unite with carbon.

Vanadium: It

- 1) promotes fine grains in steel.
- 2) increases hardenability.
- 3) imparts strength & toughness to heat-treated steel
- 4) causes marked secondary hardening.

Molybdenum: It

- 1) promotes hardenability of steel.
- 2) makes steel fine grained.
- 3) makes steel unusually tough at various hardness levels.
- 4) counteracts tendency towards temper brittleness.
- 5) raises tensile & creep strength at high temperatures.
- 6) enhances corrosion resistance in stainless steels.
- 7) forms abrasion resisting particles.

Tungsten: It

- 1) increases hardness.
- 2) promotes fine grains.
- 3) resists heat.
- 4) promotes strength at elevated temperature.

Iron – Carbon system

Concept of phase diagram

A phase in a material is defined as a region of spatially uniform macroscopic physical properties like density, atomic arrangement, crystal structure, chemical composition etc.

Example

Iron in bcc structure, fcc structure, in liquid form and in gaseous state are different phases of iron.

In one component materials a phase is stable over a range of temperature and pressure.

A

homogeneous solution of two or more components that may exist over a range of composition, temperature and pressure is considered as the same phase.

Equilibrium phase diagrams are normally used to show the stability of different phases in a material as function of temperature, pressure and composition.

General features of phase diagrams are constrained by conditions of thermodynamic equilibrium. When no chemical reactions occur between different components in a system, then

the phase rule can be stated as $f = C - P + 2$

Where, C is number of components in the system;

P is number of phases in equilibrium,

2 represents temperature and pressure as independent variables,

f is degree of freedom. It is the maximum number of variables that may be independently varied without changing the number of phases in equilibrium.

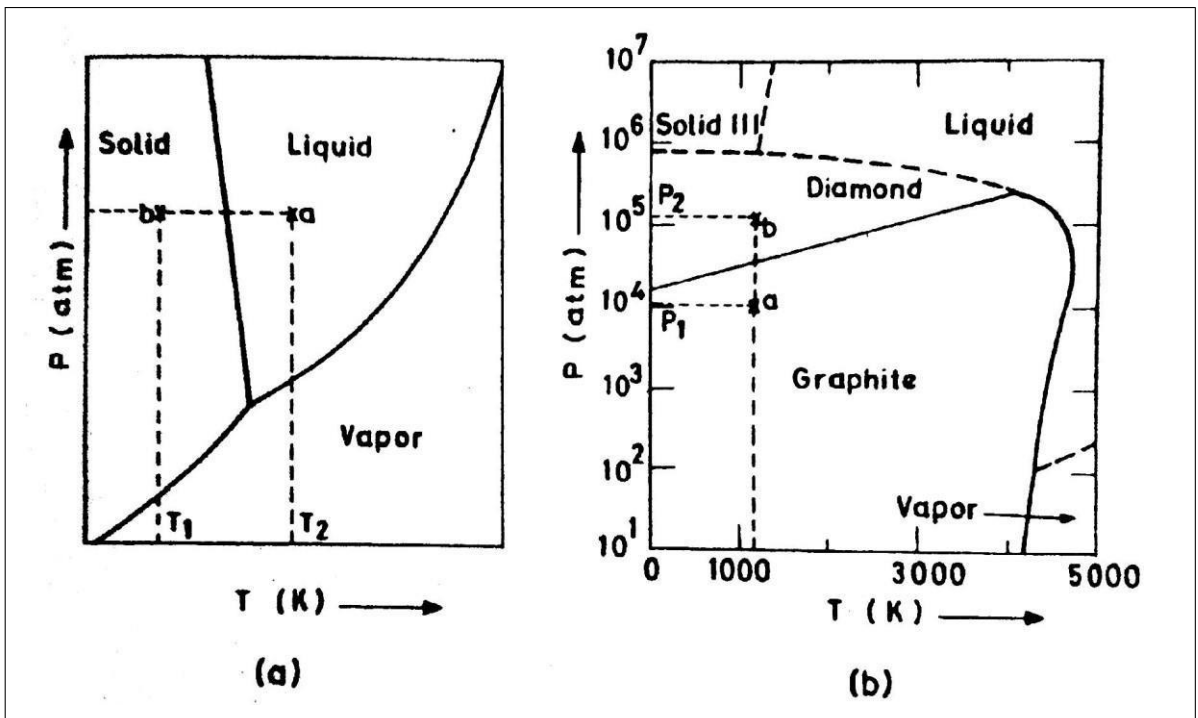

Chalk, Blackboard and PPT

The fig. 3.1 shows phase diagrams of two one component system, H₂O and carbon as a function of temperature and pressure. In a single phase regions both P and T may be independently varies.

In two component (binary) systems, there are three independent variables i.e, temperature,

- pressure and relative concentration of one of the component

Chalk, Blackboard

Colling Curves

Durring heat treatment there phase transferring taken place by colling the steel.

Example

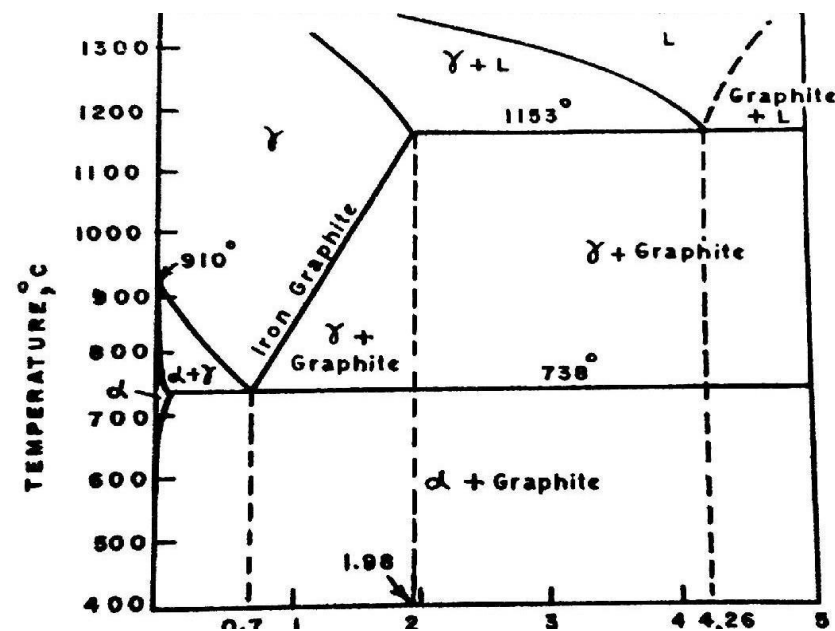
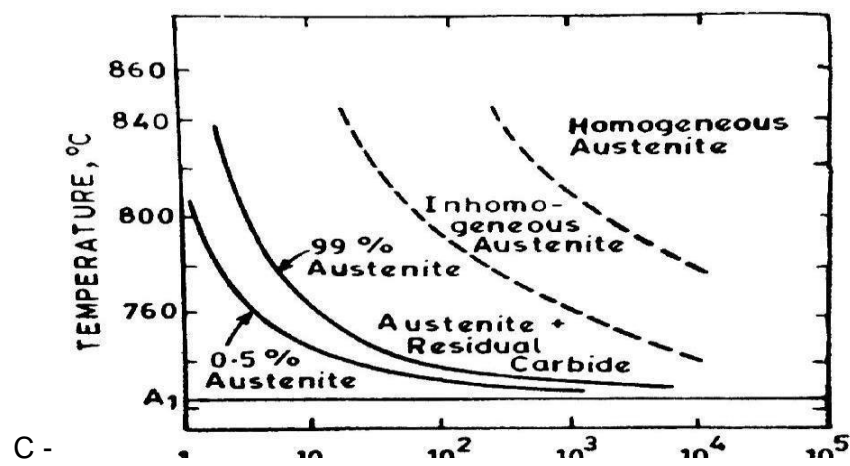

3.2- Features of iron on carbon diagram with silent Micro-constituents of iron and steel

Fig-3.3 –Iron – Carbon phase diagram

At all temperatures, the following reaction takes place : Fe₃C cooling 3Fe + C (graphite)

At higher temperatures, the graphitization of the iron- carbide occurs.

The above figure is an iron-carbon phase diagram. As the liquid alloy cools to 1153°C dendrites

of austenite phase starts forming in the liquid. At 1153°C, the liquid reaches

eutectic composition

and solidifies as a eutectic mixture of austenite and graphite. Upon subsequent

slow cooling, additional

graphite forms from the austenite and eutectoid graphite is formed in the

temperature interval from

738°C to 723°C.

If austenite is super cooled below 723°C it decomposes with the separation of a

ferrite-cementite

mixture. Rapid cooling inhibits precipitation of graphite partially or completely and

promotes

formation of cementite. If liquid cast iron is super cooled below 1147°C cementite

is precipitated.

The precipitation of graphite from the liquid phase is possible only at very slow

cooling rates i.e

when the degree of super cooling does not exceed 5°C.

The rapid cooling prevents graphitization of cementite in white cast iron, but if the

casting is

reheated to about 875°C and held there for long time, then graphite is slowly

produced in the form

of temper carbon. This is called malleable cast iron.

CRYSTAL IMPERFECTIONS

Definition of crystal

Whenever atoms arrange themselves in an orderly repetitive three dimensional pattern a crystal is formed.

It is a solid which consists of atoms arranged in a pattern in 3-D.

A perfect crystal is constructed by the infinite regular repetition in space of identical structural units or building blocks.

The symmetry is an important characteristic of most of the crystals.

e.g cube and octahedrons are simple form of the crystal.

All metals are crystalline, where atoms are arranged in a definite periodic order.

Classification of Crystals

On the basis of periodic arrangement of atoms crystals are grouped into seven systems.

The systems are :

Cubic, tetragonal, orthorhombic, rhombohedral, hexagonal, monoclinic and triclinic.

In the present context, only cubic and hexagonal crystal structures are considered as most

of the metals and alloys belong to these two systems.

In crystal structure, the smallest unit is one unit cell which characterizes the specific

arrangement and location of atoms.

There are three types of unit cells with cubic crystal structure such as SC, BCC, FCC

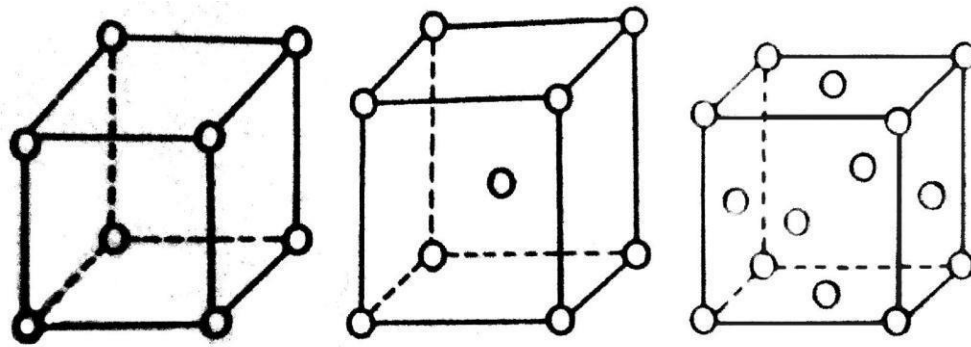

Simple cubic

(FCC)

[FCC

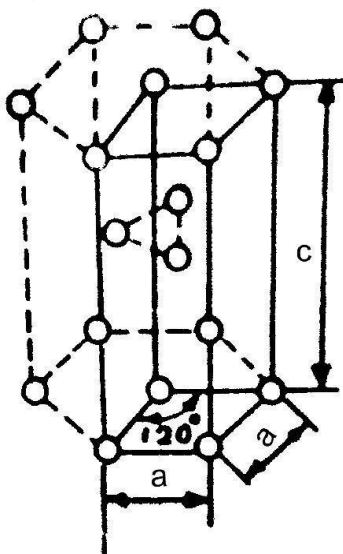

EX ---Be,Tc,Zn

(Hexagonal crystal structure)

Ideal Crystals

In ideal crystals, the angles between the faces required to determine the crystal form are same.

Crystal Imperfections

Crystals are not perfect. An important characteristic which determines some important properties of crystalline materials is the presence of imperfections. Except some ideal crystals most of the crystals have some type of defects or imperfections. All crystals are not composed of identical atoms on identical sites throughout a regularly repeating 3D lattice. These imperfection or defects are used to describe any deviation from an orderly periodic array of atoms and influence the characteristics like mechanical strength, electrical properties and chemical reactions.

4.2 Classification of imperfections

Defects one classified into point, line or plane and volume imperfections

Types and causes of point defects

Point Defects

In crystal lattice, point defect is completely local in its effect. When point defect gets introduced in crystal lattice, internal energy of the crystal increases.

Types

Vacancies, interstitialcies and impurities are example of point defctes.

Causes

A vacant lattice site is a point defect.

Vacancies

The number of vacancies at equilibrium present in a crystal at a given temperature can be determined by the equation.

$$n_0 = N e^{-E/KT}$$

Where n_0 = number of vacancies per mole

N = total number of atomic sites per mole.

E = activation energy for formation of vacancy.

K = Boltzman's constant.

T = Temperature in absolute scale.

Vacancies are atomic sites from which the atoms are missing and exist in metal at all

temperatures above absolute zero. It play a great role in diffusion of atoms in the crystal lattice. It

arises from thermal vibrations and introduced during solidification.

Interstitialcies

When an atom is displaced from a regular site and occupies an interstitial site, an interstitialcy is formed. It also gives rise to lattice distortion because interstitial atom tends to push the surrounding atoms apart. The smaller the size of interstitial atoms smaller the defect

mpurities

Impurities are foreign atoms which are present in the crystal lattice. Impurity atoms may occupy either interstitial or substitutional position. It is a small atom occupies an interstitial void space between atoms at lattice points of the crystal

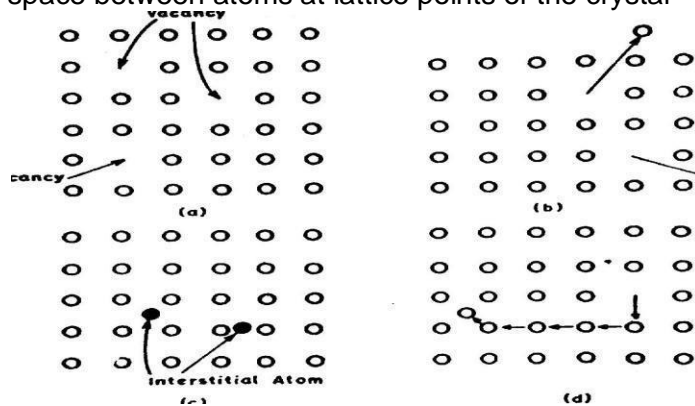
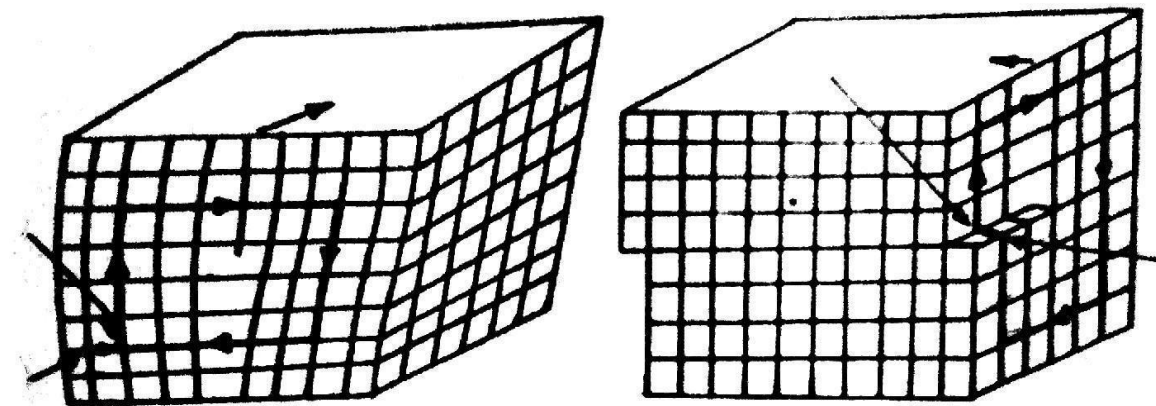

Fig 3.5 Various types of point defects. (a) Vacancy, (b) Schottky defect, (c) Interstitialcy, (d) Frankel defect.

4.4. Types and causes of line defects, Edge dislocation and screw dislocation.

Line Defects

Line defects are also known as dislocations. Dislocation is the region of localized lattice disturbance between slipped and unslipped regions of a crystal. Due to lattice disturbances, elastic strain fields and stresses are associated with dislocations



Types

Dislocations are of two types : (1) Edge dislocation (2) Screw dislocation

Edge dislocation

In the figure of edge dislocation in which a burger's vector lies perpendicular to the dislocation line. A burger circuit is drawn around the dislocation line and the vector required to close the circuit

RS is known as the burger vector of the dislocation. An edge dislocation moves in the direction of the burger vector. It has an extra row of atoms either above or below the slip plane in crystal.

When the extra row of atoms is above the slip plane it is called positive and is denoted by sign \bullet . When the extra row of atoms is below the slip plane, it is called negative edge dislocation and is represented by sign \top . Here the atoms above the edges are in compression and those below are in tension.

Screw dislocation

Here the burger vector is parallel to the dislocation line and distortion is of shear type. It follows a helical path and it may follow right hand or left hand screw rule. Positive and negative dislocations are shown by clockwise and anticlockwise signs, respectively. It shows cross slip, where it moves from one slip plane to another.

Either edge or screw of opposite signs if present in the same line, attract each other and can annihilate each other.

s. Effect of imperfections on material properties.

It affects or influence the characteristics like mechanical strength, electrical properties and chemical reactions. The role of imperfections in heat treatment is very important.

Imperfections

account for crystal growth, diffusion mechanism, annealing and precipitation, besides this, other metallurgical phenomena, such as oxidation, corrosion, yield strength, creep, fatigue and fractures' are governed by imperfections. Imperfections are not always harmful to metals. Sometimes they are generated to obtain the desired properties. For example, carbon is added to steel as interstitial impurity to improve the mechanical properties and this properties are further improved by heat treatment.

deformation by slip and twinning

Slip - Metals deform plastically by slip. Slipping is facilitated in the presence of dislocation.

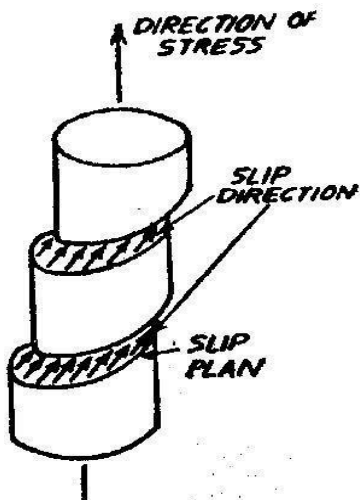

Slip is defined as the process or mechanism by which a large displacement of one part of the crystal relative to another along particular crystallographic planes takes place. There may be one or more slip planes and one or more slip directions in each crystal. Slip

begins when the shearing stress acting along the slip planes in the direction of slip exceeds a

certain value known as critical slip planes are planes of high atomic densities while the direction of slip along these planes is always the direction of highest atomic density.

Twins and Twinning

Other than slip, twinning also gives rise to plastic deformation in crystals. It may be called as

a special case of slip movement. In twinning, instead of whole blocks of atoms moving different

distances along the slipping planes, each plane of atoms concerned moves a definite distance and

the total movement at any point relative to the twinning plane is proportional to the distance from

this plane. In bcc and hcp it occurs frequently.

Effect of deformation on material properties

The mechanical properties are greatly affected by deformation i.e plastic deformation. The deformation process like rolling, forging, extrusion, drawing. Strain hardening takes place, so

hardness changes. Elasticity changes, cracking takes place, grain growth

Heat Treatment

Purpose of heat treatment

Definition- It may be defined as heating and cooling operations applied to metals and alloys in solid state so as to obtain the desired properties.

The object of this process is to make the metal better suited, structurally and physically, for some specific applications. Heat treatment may be undertaken for the following purposes.

- (i) Improvement in ductility
 - (ii) Relieving internal stresses
 - (iii) Refinement of grain size
 - (iv) Increasing hardness or tensile strength and achieving changes in chemical composition of metal surface as in the case of case-hardening.
- Also compress machinability, alteration in magnetic properties, modification of electrical conductivity, improvement in toughness and development of re-crystallized structure in cold-worked metal.

Process of heat treatment

Annealing

Annealing involves heating to predetermined temperature, holding at this temperature and finally cooling at a very slow rate. The temperature to which the steel is heated and the holding time

are determined by various factors such as chemical composition of steel, size and shape and final properties required. The various purposes for this treatment are to

- (i) Relieve interval stresses developed during solidification, machining, forging, rolling or welding.
- (ii) Improve or restore ductility and toughness.
- (iii) Enhance machinability.
- (iv) Eliminate chemical non-uniformity.
- (v) Refine grain size.
- (vi) Reduce the gaseous contents in steel.

| Chalk, Blackboard and PPT |

Normalizing

Normalizing is a process of heating steel to about 40-50°C above upper critical temperature, holding for proper time and then cooling in still air or slightly agitated air to room temperature. After

normalizing the resultant microstructure should be pearlite. This is important for some alloy steels

which are air hardening by nature. Better dispersion of ferrite and cementite in the final structure

results in enhanced mechanical properties. The grain size is finer and refinement of grain size.

Rolled and forged steels possessing coarse grains due to high temperatures involved are subjected

to normalizing. Normalized steels are generally stronger and harder than fully annealed steels.

critical temperature.

Hardening

Hardening consists of heating to hardening temperature, holding at that temperature, followed

by rapid cooling such as quenching in water oil or salt baths. High hardness developed by this

process is due to phase transformation with rapid cooling. For plain carbon steels, it depends on

carbon content. Hypoeutectoid steels are heated to about 30 – 50°C above the critical temperature

where as eutectoid and hyper eutectoid steels are heated to about 30 – 50°C above the lower

- critical temperature.

Tempering

The process which consists of heating hardened steel below the lower critical temperature,

followed by cooling in air or at any other desired rate, is known as tempering. This treatment lowers

hardness strength and wear resistance of the hardened steel marginally. The higher the tempering

temp, the more is the restored ductility and toughen the steel.

Proper tempering treatment results

is optimum combination of mechanical properties. Elastic properties is affected by this. Hardening

followed by tempering will improve elasticity.

5.3- Surface Hardening

In order to process considerable strength to with stand forces acting on them and to withstand

wear on their surface, the parts must be made of tough materials and provided with a hard surface

by introducing carbon or nitrogen on its surface with core remaining soft. Surface hardening or

case-hardening provides us a hard and wear resistant surfaces,

close tolerance in machining parts and tough-core combined with a higher fatigue limit and high mechanical properties in core.

It is carried out by following operations

- (a) carburising (d) Cyaniding
- (b) Nitriding (e) Induction hardening
- (c) Carbonitriding (f) Flame hardening.

Carburising

It is the process of producing a hard surface on low carbon steel parts. There are three methods of carburising such as (a) pack or solid carburising (b) Gas carburising (c) Liquid carburising. Liquid carburising is performed in activated bath of calcium cyanamide, sodium or potassium cyanide and other controlling chemicals which govern the decomposition of the cylinders. The baths are operated at 815.5°C to 898.85°C produce a case of depth of 0.5mm in 90 minutes. The process extremely flexible and easily controlled. The reaction in the bath is $2\text{Na}_2\text{CO}_3 + \text{SiC} \rightarrow \text{Na}_2\text{SiO}_3 + \text{Na}_2\text{O} + 2\text{CO} + \text{C}$.

Nitriding

The introduction of nitrogen into the outer surface of steel parts in order to give an extremely hard, wear resisting surface is called nitriding. It is provided by placing the article in ammonia vapour a temperature between 450°C and 550°C for 10 hours. The core should be brought to its original toughness before nitriding by quenching in oil from about 900°C and tempering from about 600°C to 650°C. It is used for various automotives, airplane and diesel engine parts like cylinders, sleeves, liners etc.-

Hardenability

It is defined as property of a steel to be hardened by quenching and determined the depth and distribution of hardness throughout a section obtained by quenching.

Factors are as follows

The main factors affecting hardenability are:

- (a) Alloying elements
- (b) Carbon content
- (c) Grain size of steel
- (d) The homogeneity of starting steel
- (e) Homogeneity obtained in the austenite before quenching by increasing carbon content, hardness can be increased.

NON - FERROUS ALLOYS

Duralmin

It is one of the oldest and best known alloys of aluminium widely used for aircraft parts. Its composition is 3.5-4.5% copper, 0.4-0.7% manganese, 0.4% silicon and sometimes contain 0.4-

0.7%, magnesium and below 0.5% iron.

It developed maximum properties as a result of heat treatment and age hardening which can be worked readily about 500°C and after quenching ages over a period of 4 to 5 days. Its tensile

strength increase from 1.55-1.86ton/cm² yield point from 1.04-2.325 t/cm² and hardness from 65

brinell to 95 brinell.

Used for highly stressed structural components, aircrafts and automobile parts like front axle, levers, bonnets, connecting rods, chassis from, girders for ships, aeroplane air screws, spares, clips, fitting, levers etc.

Also used for surgical and orthopaedics works for non magnetic and other instrument parts

. Y-alloys

Y-alloys are of the best alloys of this groups is a high strength costing alloy which retains its strength and hardness at high temperature.

Its percentage composition is 4% copper, 1.5% magnesium and 2% nickel, each of silicon, manganese is 0.6%. In the cost and heat treated from its ultimate strength is 2.12 tons/cm² but

chill costing after heat treatment show a strength of 3.1 tonnes/cm². Heat treated forged alloys

give an ultimate strength of 3.565 – 4.185 ton/cm² an elongation of 17 – 22% and brinell hardness of 100-105.

It is extensively used for pistons, cylinder heads and crank case of internal combustion engine

Copper alloys

(a) Copper- Aluminium alloys

Aluminium gets hardened and strengthened by the addition of copper. The most extensively used alloys for castings are those containing 4,5,7,10 and 12% of copper and with ultimate strength

ranging from 1.12 – 4.185 t/cm². It is employed in industry for light casting requiring greater strength

and hardness than ordinary aluminium.

It is used for automobile piston, crank cases, cylinder heads, connecting rods

(b) Copper-Tin

These bearing alloys containing greater proportion of tin with copper and antimony and known

as white metals.

Another alloys of this type having composition of 86% tin, 10.5% antimony, 3.5% copper has a tensile strength of 0.996 t/cm², elongation 7.1% with brinell hardness of 33.3 and compressive yield point of 4.3.

It is used in main bearings of motors and aero-engines.

(c) Babbot

It is a general white metal alloy with soft lead and tin base metals covering a range of alloy having similar characteristics varying composition. Its actual composition is 82.3% tin, 3.9% copper, 7.1% antimony.

A cheaper babbot metal used for bearings subjected to moderate pressure has composition as 59.54% tin, 2.25 to 3.75% copper, 9.5 to 11.5% antimony, 26% lead, 0.08% iron, 0.08% bismuth.

They are use as liners in bronze or steel backing and are prepared for higher speed, excellent embedability, conformability, ability to deform plastically used in IC engine bearing, general machinery purpose bearings.

(d) Phosphorous bronze

The phosphorous bronzes are the alloys of copper and tin with 0.1 to 1.5% phosphorous. Phosphorous is added both for deoxidising the tin oxide and developing the structure and general properties of the metal. In the form of casting phosphorous bronze gives and ultimate strength of

about 18 tonnes /cm² with elongation of 4% brinell hardness number 80-100. It is used for heavy compressive loads and is used for gear wheels and slide valves. Phosphorous bronze in wrought

alloy form containing 10% tin, 0.1 – 0.35% phosphorous has a tensile strength 3.72 t/cm², Bhn 100 – 130. It has good corrosion resistance to sea water and is used for spring and turbine blades.

(e) Brass

These are the alloys of copper and zinc with varying percentage of two metals. If small amount of one or more metals are added they provide more specific properties like colour, strength, ductility, machinability.

- - brasses- 36% zinc and 64% cu.

- • – brasses – 40 to 44% zn and 64 to 55% cu.

- – brasses possess good tensile strength, good ductility, suitable for producing sheet, strips, tubes, wires etc.

- • – brasses are used for hot pressings, stampings.

Copper-Nickel

Nickel forms with copper in varying properties a large number of alloys. The addition of even a small amount of nickel to copper has a marked effect upon its mechanical properties and increase its corrosion resistance.

Cupro-Nickel has a nickel content between 10 – 30% has remarkable drawing properties with tensile strength of 6.2 t/cm² used for sheaths or envelopes of rifle bullet.

A 70/30 cupro nickel used for condenser tubes produced by extrusion process. 8 t/cm² elastic limit, 5.9 t/cm² ultimate strength, Bhn 140.

.

Lead alloys

The tin is replaced by lead base alloys and contains 10 – 15% antimony, 15% Cu, 20% Tin and 60% Lead. These alloys are cheaper than tin base alloys, but not strong and do not possess

the lead carrying capacity strength decreases with increasing in temperature. An alloy containing

80% lead, 15% antimony and 5% tin or 20% antimony generally used for long bearings with medium loads.

Binary copper lead alloys- lead 10 – 20%, 20 – 30% and above 30%.

Zinc alloys

These alloys used in the form of tooling plate and easy and speed of fabrication.

Brasses – Alloys of Cu and Zn.

Nickel alloys

Nickel is one of the most important metals which is used as a pure metal and alloyed with other elements.

Nickel copper, nickel copper silicon alloys.

Nickel copper tin, sometimes with lead.

Nickel chromium- with iron or cobalt.

Nickel molybdenum-also with chromium.

Nickel silicon.

Nickel manganese, nickel aluminium.

Low alloy materials like P-91, P-22 for power plants and other high temperature services,

high alloy materials like stainless steel grades of duplex, stiper duplex materials.

Low alloy materials

Which possess slowly cooled micro structures, similar to those of plain carbon steel in the same condition namely pearlite, pearlite plus ferrite. These low alloy also known as pearlite alloy steel.

High alloy steel

Which possess slowly cooled micro structure, consisting either of martensite, austenite or ferrite plus carbide particle. It is more than 8% in the case of steel.

Bearing Material

Introduction

When a lubricant film cannot completely separate the moving parts of a bearing, friction

and wear increase. The resulting frictional heat combined with high pressure promotes localized

welding of the two rubbing surfaces. These welded contact points break apart with

relative motion and metal is pulled from one or both surfaces decreasing the life of the bearing. This friction and welding is most common when like metals, such as steel or cast iron, are used as bearings – they easily weld together. Compatibility of bearing materials, therefore, and absorption of lubricant upon the bearing surface, is necessary to reduce metallic contact and extend bearing life. **Babbitt** In 1839, Isaac Babbitt received the first patent for a white metal alloy that showed excellent bearing properties. Since then, the name babbitt has been used for other alloys involving similar ingredients. Babbitts offer an almost unsurpassed combination of compatibility, conformability, and embedability. They easily adapt their shapes to conform to the bearing shaft and will hold a lubricant film. Foreign matter not carried away by the lubrication is embedded below the surface and rendered harmless. These characteristics are due to babbitt's hard/soft composition. High-tin babbitts, for example, consist of a relatively soft, solid matrix of tin in which are distributed hard copper-tin needles and tin-antimony cuboids. This provides for "good run-in" which means the bearing will absorb a lubricant on the surface and hold the lubricant film. Even under severe operating conditions, where high loads, fatigue problems, or high temperatures dictate the use of other stronger materials, babbitts are often employed as a thin surface coating to obtain the advantages of their good rubbing characteristics.

Classification of Bearing Material

1. Tin Based Babbitt
2. Lead based Babbitt
3. Cadmium Based Bearing Material
4. Copper based Bearing Material (Cintered Metal)

Composition & uses of different type of Bearing material.

Name Composition(Wt %) Uses

Tin Based Babbitt 85Sn-10Sb-5Cu High speed bearing bushes in steam and gas turbine, electric motor, blower, pumps etc.

Lead Based Babbitt 80Pb-12Sb-8Sn Railway Wagon bearing.

Cadmium Based 95cd-5ag & small amount of iridium Medium loaded bearing

subjected to high temperature

Copper Based 80Cu-10Pb-10Si Heavy duty bearing.

Properties of Bearing Material

A bearing metal should possess the following important properties.

- i) It should have enough compressive and fatigue strength to possess adequate load carrying capacity.
- ii) It should have good plasticity for small variations in alignment & fittings.
- iii) It should have good wear Resistance to maintain a specified fit.
- iv) It should have low co-efficient of frictim to avoid excessive heating.
- v) The material should resist vibration.
- vi) It should have high Thermal conductivity so as to take away the heat produced due to friction between two moving parts.
- vii) It should have the properties to from a continuous thin film of lubricant between the shaft & bearing to avoid direct contact between two rotating surface.

Spring materials

Introduction

Springs are fundamental mechanical components found in many mechanical systems. Developments in material, design procedures and manufacturing processes permit springs to be made with longer fatigue life, reduced complexity, and higher production rate. Most springs are linear which means the resisting force is linearly proportional to its displacement. Linear springs obey the Hooke's Law, $F = k \times Dx$ Where F is the resisting force, k is the spring constant, and Dx is the displacement. Depending on load characteristics spring may be classified as :

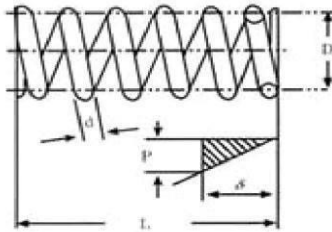

compression

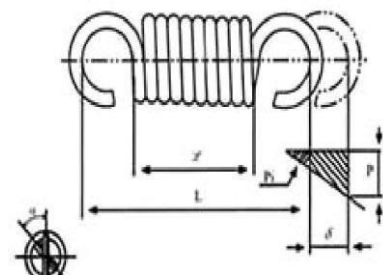

Tension

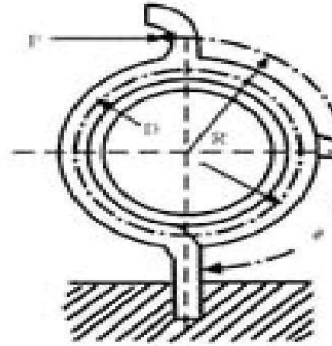

compression

1 Spring Material

Most springs are made with iron-based alloy (high-carbon spring steels, alloy spring steels, stainless spring steels), copper base spring alloys and nickel base spring alloys.

.1.1 Iron-based alloy

i) High Carbon Spring Steel –(C 0.7-1.0, Mn 0.3-0.6 & remaining Fe) These spring steels are the most commonly used of all spring materials because they are the least expensive, are easily worked, and are readily available. They are not suitable for springs operating at high or low temperature or for shock or impact loading.

ii) Alloy Spring Steel –EN-45(C 0.5, Mn 1.0, Cr 0.2-0.9, V 0.12 & remaining Fe), EN-60(C 0.5-0.75, Mn 0.6-1.2 & remaining Fe). These spring steels are used for conditions of high stress, and shock or impact loadings. They can withstand a wider temperature variation than high carbon spring steel and are available in either the annealed or pre-tempered conditions.

iii) Stainless Spring Steel –(Cr 18, Ni 8, C 0.1-0.2 & remaining Fe) The use of stainless spring steels has increased and there are compositions available that may be used for temperatures up to 288°C. They are all corrosion resistant but only the stainless 18-8 compositions should be used at sub-zero temperatures. They are suitable for valve springs.

Copper Base Spring Alloys

Copper base alloys are more expensive than high carbon and alloy steels spring material. However they are frequently used in electrical components because of their good electrical properties and resistance to corrosion. They are suitable to use in sub-zero temperatures.

i) Brasses (Cu 67, Zn 33): Switch control, electrical application.

ii) Nickel Silver (Cu 56, Ni 18, Zn 18): Electrical relays.

iii) Pb Bronze (Cu 92, Sn 8, Pb 0.1): Bushes.

iv) Beryllium Copper (Cu 98, Be 2.0): Relays and Bushes

Nickel Base Spring Alloys

Nickel base alloys are corrosion resistant, and they can withstand a wide temperature fluctuation.

The material is suitable to use in precise instruments because of their non-magnetic characteristic, but they also pose a high electrical resistance and therefore should not be used as an electrical conductor.

- i) Monels (Ni 68, Cu 27 & remaining Fe and Mn)
- ii) Inconels (Ni 76, Cr 16 & Fe 8)
- iii) Chromels (Ni 80, Cr 20)
- iv) Nichrome (Ni 60, Cr 16 & Fe 24)

- v) Elinver (Ni36, Cr12 & rest Fe)
- vi) Inver (Ni35, Fe65)

Properties of Spring Materials

1. It should possess high modulus of elasticity.
2. It should have high elastic limit
3. It should have high fatigue strength
4. It should have high creep strength
5. It should have high notch toughness
6. It should have good resistance to corrosion
7. It should have high electrical conductivity

Spring Resonance

The dynamic behaviors of springs have to be analyzed when they are used in a moving mechanism.

The nominal frequency of operation should be well under the spring's first resonant frequency;

typically about 15-20 times lower for safety reason. The force the spring exerts as it approaches its

resonant frequency will tend to decrease, which could have disastrous implications for the spring assembly.

Polymers

Polymer :

The plastic is an organic substance and it consists of natural or synthetic binders or resins

with or without moulding compounds. The plastic is manufactured by the polymerization.

A polymer consists of thousands of monomers joined together.

Monomer:

The simplest substance consisting of one primary chemical are known as the monomer.

Polymerization:

Monomers are to be combined to form polymers by the process known as polymerization.

The polymer molecule is also called a macromolecule.

A polymeric material consists of a large number of these long chain molecules.

The properties such as strength, rigidity and elasticity are considerably improved by the polymerization and it further leads to the manufacture of plastics in an economy way.

CLASSIFICATION OF PLASTICS

The classification of plastics can be made by considering various aspects and for the purpose

of discussion, they can be classified according to their

1. Behaviour with respect to heating.
2. Structure and
3. Physical and chemical properties.

As case-1 is the topic of our discussion we will concentrate on that.

1. Behaviour with respect to heating

According to this classification the plastics are divided into two groups:

(i) Thermo-Plastic

(ii) Thermo-Setting

The above classification is based on the inherent characteristics of each group.

These two

groups can further be divided into several distinct sub-divisions. These sub-divisions are based on

the raw materials from which plastics are prepared. It is interesting to note that each of above

group contains several hundred different products and with the advance of plastic industry, the

number of sub-divisions under each category is constantly increasing.

(i) Thermoplastic polymer

The thermo-plastic or heat nonconvertible group is the general term applied to the plastics which become soft when heated and hard when cooled. The process of softening and hardening

may be repeated for an indefinite time. Provided the temperature during heat is not so high as to

cause chemical decomposition. It is thus possible to shape and reshape these plastics by means

of heat and pressure. One important advantage of this variety of plastics is that the scrap obtained

from old and worn-out articles can be effectively used again.

(ii) Thermosetting polymer

The thermosetting or heat convertible group is the general term applied to the plastics which become rigid when moulded at suitable pressure and temperature. When they are heated in temperature range of 127°C to 177°C, they set permanently and further application of heat does

not alter their form or soften them. But at temperature of about 343°C, the charring occurs.

This

charring is a peculiar characteristic of the organic substances.

Properties

The thermo setting plastics are soluble in alcohol and certain organic solvents when they are

in thermo-plastic stage. This property is utilised for making paints and varnishes from these plastics.

These plastics are durable, strong and hard. They are available in a variety of beautiful colours. They are mainly used in engineering application of plastics.

Properties of plastics

1. Appearance : Transparent
2. Chemical resistance : The plastics offer great resistance to moisture, chemicals and solvents, excellent corrosion resistance.
3. Dimensional stability.
4. Ductility : The plastic lacks ductility. Hence its members may fail without warning.
5. Durability : The plastics are quite durable, if they possess sufficient surface hardness.
6. Electric insulation : They are far superior to ordinary electric insulators.
7. Finishing : Any surface treatment may be given to the plastics.
8. Fire resistance : All plastics are combustible.
9. Fixing : Can be easily fixed in position.
10. Humidity : PVC plastics offer great resistance to the moisture.
11. Maintenance : It is easy to maintain plastic surfaces. They do not require any protective coat of paints.
12. Melting point : Most of the plastics have low melting point and MP of some plastics is only about 50°C.
13. Optical property : Several types of plastics are transparent and translucent.
14. Recycling : It does not give a serious problem to pollution as generated by a host of other industries. The plastics used for soft drink bottle, milk and juice bottles, bread bags, syrup bottles, coffee cups, plastic utensils etc can be conveniently recycled into carpets, detergent bottles, drainage pipes, fencings, handrails, grocery bags, car battery cases pencil holders, benches, picnic tables, roadside posts etc.

15. Sound absorption : The acoustical boards are prepared by impregnating fibre-glasses with phenolic resins. This material has absorption coefficient of about 0.67.

16. Strength : The tensile members are generally made of plastics as their strength to weight ratio in tension very nearly approaches to that of metals.

17. Thermal property : The thermal conductivity of plastics is low and it can be compared with that of wood.

18. Weather resistance : Certain plastics are seriously affected by sun light, but other plastic can resist weather which is prepared from phenolic resins.

19. Weight : The plastics, whether thermo-plastic or thermo-setting have low specific gravity.

Applications :

The typical use of plastics in building are as follows :

1. Bath and sink units.
2. Cistern ball floats.
3. Corrugated and plain sheets.
4. Decorative laminates and mouldings.
5. Electrical conduits.
6. Electrical insulators.
7. Floor tiles.
8. Foams for thermal insulation.
9. Joint less flooring.
10. Lighting fixtures.
11. Overhead water tanks.
12. Paints and varnishes.
13. Pipes to carry cold water.
14. Roof lights.
15. Safety glass.
16. Wall tiles.

9.2 Properties of Elastomers

These plastics are soft and elastic materials with a low modulus of elasticity. They deform considerably under load at room temperature and return to their original shape, when the load is

released. The extensions can range up to ten times their original dimensions.

Composites and Ceramics

Classification

The composite materials are shortened as composites. They are formed by combining two or more different materials to make better use of their virtues and by minimizing their deficiencies.

Each material retains its physical or chemical properties separate and distinct within the finished product.

Composition

The composites are made from two main constituent materials.

1. Strong load carrying material known as reinforcement or reinforcing fibres.
2. Weaker material known as matrix.

1. Reinforcing fibres

Following are the functions of reinforcing fibres :

- (i) It provides strength and rigidity.
- (ii) It helps to support structural load.

There are three most common types of reinforcing fibres.

- (i) Glass fibres
- (ii) Carbon fibres
- (iii) Aramid fibres

Glass fibers are the heaviest having greatest flexibility and the lowest cost. Aramid has moderate stiffness and cost.

Carbon is moderate to high in cost, slightly heavier than aramid but lighter than glass fibres. Carbon is the strongest.

2. Matrix

Following are the functions of matrix.

- (i) It works as a binder
- (ii) It maintains the position and orientation of the reinforcement.
- (iii) It balances the loads between the reinforcement.
- (iv) It protects the reinforcement degradation.
- (v) It provides shape and form to the structure.

The most common type of matrix is thermosetting resins.

Epoxy resins are the most widely used thermo setting resins in advanced composites. Others resins used as matrix are polyester, vinyl ester, phenolic, bismaleimide, epoxy novolar.

Examples :

Composites natural

Wood - Cellulose fibres plus polysaccharide.

Bones, teeth and mollusc shells = Hard ceramic + organic polymer

Man made composites

1. Mud + straw
2. Bricks made up straw + mud
3. Plywood
4. Concrete, plastic, MMC, CMC

Classification and Uses of Ceramics

The term ceramics is used to indicate the potter's art or articles made by the potter.

The ceramics are divided into the following three categories.

1. Clay products
2. Refractories
3. Glass

Clay products

The clay products which are used are tiles, terra-cotta, porcelain, bricks, stoneware's & earth wares.

Tiles are of two types

- (1) Common tile
- (2) Encaustic tiles

Types of common tiles

- (i) Drain tiles
- (ii) Floor or paving tiles
- (iii) Roof tiles

Types of roof tiles

Allahabad tiles, Corrugated tiles, Flat tiles, Flemish tiles, Guna tiles, Mangalore tiles, pan tiles.

Refractories

The term refractories is used to indicate substances that are able to resist high temperatures.

Classification

- (i) According to chemical properties.
- (ii) According to resistance to temperature.

According to chemical properties

- (a) Acidic
- (b) neutral and
- (c) Basic

(a) Acidic

Fire clay: It is used for the manufactured of fire bricks, crucibles, hollow tiles.

Quarizite- For making the silica bricks.

Silica- Coke over and lining for glass furnaces.

(b) Neutral refractory materials

Bauxite- For tire bricks

Carbon- Lining material for furnaces

Chromite- Powerful neutral refractory material.

Forsterite- Used in furnaces for melting copper.

(c) Basic Refractory materials

Dolomite- For making refractory bricks.

Magnesia- Magnesia bricks.

According to resistance to temperature

- (a) Low quality
- (b) High quality

High quality - Used in modern aeroplanes, rockets, jets etc. Molybdenum, tungsten, zirconium and their alloys are used as the refractory materials.

Cermet - Refractory material containing a combination of clay and metal.

Surface Preparation and Industrial Painting

11.1 – Reasons of corrosion and surface wear.

The term corrosion is defined as an act or process of gradual wearing away of a metal due to

chemical or electro-chemical reaction by its surroundings such that the metal is converted into an oxide.

The corrosion indicates the deterioration and loss of material due to chemical attack.

Following are the factors responsible for corrosion :

- (i) Congested reinforcement in small concrete sections.
- (ii) Excessive water-cement ratio.
- (iii) Improper construction methods.
- (iv) Inadequate design procedure
- (v) Incompetent supervising staff or contractor.
- (vi) Initially rusted reinforcement before placing concrete.
- (vii) Insufficient cover to steel from the exposed concrete surfaces.
- (viii) Presence of moisture in concrete.
- (ix) Presence of salt.
- (x) Unequal O₂ distribution over the steel surfaces.

Factors influencing corrosion

- (i) Blow holes, inclusions trapped gases.
- (ii) Chemical nature of the metals.
- (iii) Eddy electric currents.
- (iv) Presence of dust, dirt.

11.2- Purpose of painting and methods of industrial pointing:

Purposes

- (i) To protect the surface from weathering effects of the atmosphere and actions by other liquids, fumes and gases.
- (ii) To prevent decay of wood and corrosion in metal.
- (iii) To give good appearance to the surface. The decorative effects may be created by painting and the surface becomes hygienically good, clear, colourful and attractive.
- (iv) To provide a smooth surface for easy cleaning