



GOVERNMENT POLYTECHNIC, DHENKANAL

Programme: Diploma in Mechanical Engineering

**Course: Hydraulic Machines and Industrial Fluid Power
(Theory)**

Course Instructor's Name: Suwendu Panda

[E-mail-suwendu.panda@gmail.com](mailto:suwendu.panda@gmail.com)

Contact no- 7008362373

Semester: 6th

HYDRAULIC TURBINES

Turbines are defined as the hydraulic machines which convert hydraulic energy into mechanical energy. This mechanical energy is used in running an electric generator which is directly coupled to the shaft of the turbine. Thus mechanical energy is converted into electrical energy. The electric power which is obtained from the hydraulic energy is known as the Hydro-electric power.

Efficiency of a Turbine: The following are the important efficiencies of a turbine.

- a) Hydraulic Efficiency, η_h
- b) Mechanical Efficiency, η_m
- c) Volumetric Efficiency, η_v
- d) Overall Efficiency, η_o

a) **Hydraulic Efficiency (η_h)** it is defined as the ratio of power given by the water to the runner of a turbine (runner is a rotating part of a turbine and on the runner vanes are fixed) to the power supplied by the water at the inlet of the turbine. The power at the inlet of the turbine is more and this power goes on decreasing as the water flows over the vanes of the turbine due to hydraulic losses as the vanes are not smooth. Hence power delivered to the runner of the turbine will be less than the power available at the inlet of the turbine.

$$\eta_h = \frac{\text{Power delivered to the runner}}{\text{Power supplied at inlet}} = \frac{\text{R.P}}{\text{W.P}}$$

$$\text{R.P} = \text{Power delivered to the runner} = \frac{W}{g} \frac{[V_{w1} + V_{w2}] \times u}{1000} \text{ kW} \text{----- for Pelton Turbine}$$

$$= \frac{W}{g} \frac{[V_{w1} u_1 + V_{w2} u_2] \times u}{1000} \text{ kW} \text{----- Radial flow Turbine.}$$

$$\text{W.P} = \text{power supplied at inlet to turbine} = \frac{W \times H}{1000} \text{ kW}$$

Where W = weight of water striking the vanes of the turbine per second = $\rho g Q$

Q = Volume of water per second

V_{w1} = Velocity of whirl at inlet.

V_{w2} = Velocity of whirl at outlet u

= Tangential velocity of vane

u_1 = Tangential velocity of vane at inlet of radial vane. u_2

= Tangential velocity of vane at outlet of radial vane. H = Net

head on the Turbine.

Power supplied at the inlet of the turbine in SI units is known as Water Power.

$$W.P = \frac{\rho \times g \times Q \times H}{1000} \quad \text{K.W} \quad (\text{For water } \rho = 1000 \text{ Kg/m}^3)$$

$$= \frac{1000 \times g \times Q \times H}{1000} = g \times Q \times H \text{ kW}$$

b) **Mechanical Efficiency (η_m)** The power delivered by the water to the runner of a turbine is transmitted to the shaft of the turbine. Due to mechanical losses, the power available at the shaft of the turbine is less than the power delivered to the runner of the turbine. The ratio of power available at the shaft of the turbine (Known as S.P or B.P) to the power delivered to the runner is defined as Mechanical efficiency.

$$\eta_m = \frac{\text{Power at the shaft of the turbine}}{\text{Power delivered by the water to the runner}} = \frac{S.P}{R.P}$$

c) **Volumetric Efficiency (η_v)** The volume of the water striking the runner of the turbine is slightly less than the volume of water supplied to the turbine. Some of the volume of the water is discharged to the tailrace without striking the runner of the turbine. Thus the ratio of the volume of the water supplied to the turbine is defined as Volumetric Efficiency.

$$\eta_v = \frac{\text{Volume of water actually striking the Runner}}{\text{Volume of water supplied to the Turbine}}$$

d) **Overall Efficiency (η_o)** It is defined as the ratio of power available at the shaft of the turbine to the power supplied by the water at the inlet of the turbine.

$$\eta_o = \frac{\text{Power available at the shaft of the turbine}}{\text{Power supplied at the inlet of the turbine}} = \frac{\text{Shaft power}}{\text{Water power}}$$

$$= \frac{S.P}{W.P} = \frac{S.P}{W.P} \times \frac{R.P}{R.P}$$

$$= \frac{S.P}{R.P} \times \frac{R.P}{W.P}$$

$$\eta_o = \eta_m \times \eta_h$$

If shaft power (S.P) is taken in kW, Then water power should also be taken in kW. Shaft power is represented by P.

Water power in kW = $\frac{\rho \times g \times Q \times H}{1000}$ Where $\rho = 1000 \text{ Kg/m}^3$

$$\eta_o = \frac{\text{Shaft Power in kW}}{\text{Water Power in kW}} = \frac{P}{\frac{\rho \times g \times Q \times H}{1000}} \quad \text{Where } P = \text{Shaft Power}$$

CLASSIFICATION OF HYDRAULIC TURBINES:

The Hydraulic turbines are classified according to the type of energy available at the inlet of the turbine, direction of flow through the vanes, head at the inlet of the turbine and specific speed of the turbine. The following are the important classification of the turbines.

1. According to the type of energy at inlet:
 - (a) Impulse turbine and
 - (b) Reaction turbine
2. According to the direction of flow through the runner:
 - (a) Tangential flow turbine
 - (b) Radial flow turbine.
 - (c) Axial flow turbine
 - (d) Mixed flow turbine.
3. According to the head at inlet of the turbine:
 - (a) High head turbine
 - (b) Medium head turbine and
 - (c) Low head turbines.
4. According to the specific speed of the turbine:
 - (a) Low specific speed turbine
 - (b) Medium specific speed turbine
 - (c) High specific speed turbine.

If at the inlet of turbine, the energy available is only kinetic energy, the turbine is known as **Impulse turbine**. As the water flows over the vanes, the pressure is atmospheric from inlet to outlet of the turbine. If at the inlet of the turbine, the water possesses kinetic energy as well as pressure energy, the turbine is known as **Reaction turbine**. As the water flows through runner, the water is under pressure and the pressure energy goes on changing into kinetic energy. The runner is completely enclosed in an air-tight casing and the runner and casing is completely full of water.

If the water flows along the tangent of runner, the turbine is known as **Tangential flow turbine**. If the water flows in the radial direction through the runner, the turbine is called **Radial flow turbine**. If the water flows from outward to inwards radially, the turbine is known as **Inward** radial flow turbine, on the other hand, if the water flows radially from inward to outwards, the turbine is known as **outward** radial flow turbine. If the water flows through the runner along the direction parallel to the axis of rotation of the runner, the turbine is called **axial flow** turbine. If the water flows through the runner in the radial direction but leaves in the direction parallel to the axis of rotation of the runner, the turbine is called **mixed flow** turbine.

PELTONWHEEL(Turbine)



It is a tangential flow impulse turbine. The water strikes the bucket along the tangent of the runner. The energy available at the inlet of the turbine is only kinetic energy. The pressure at the inlet and outlet of turbine is atmospheric. This turbine is used for high heads and is named after L.A. Pelton an American engineer.

The water from the reservoir flows through the penstocks at the outlet of which a nozzle is fitted. The nozzle increases the kinetic energy of the water flowing through the penstock. At the outlet of the nozzle, the water comes out in the form of a jet and strikes the buckets (vanes) of the runner. The main parts of the Pelton turbine are:

1. Nozzle and flow regulating arrangement (spear)
2. Runner and Buckets.
3. Casing and
4. Breaking jet

1. Nozzle and flow regulating arrangement: The amount of water striking the buckets (vanes) of the runner is controlled by providing a spear in the nozzle. The spear is a conical needle which is operated either by hand wheel or automatically in an axial direction depending upon the size of the unit. When the spear is pushed forward in to the nozzle, the amount of water striking the runner is reduced. On the other hand, if the spear is pushed back, the amount of water striking the runner increases.

2. Runner with buckets: It consists of a circular disc on the periphery of which a number of buckets evenly spaced are fixed. The shape of the buckets is of a double hemispherical cup or bowl. Each bucket is divided into two symmetrical parts by a dividing wall, which is known

assplitter.

The jet of water strikes on the splitter. The splitter divides the jet into two equal parts and the jet comes out at the outer edge of the bucket. The buckets are shaped in such a way that the jet gets deflected through an angle of 160° or 170° . The buckets are made of cast Iron, cast steel, Bronze or stainless steel depending upon the head at the inlet of the turbine.

3. Casing: The function of casing is to prevent the splashing of the water and to discharge the water to tail race. It also acts as safeguard against accidents. It is made of Cast Iron or fabricated steel plates. The casing of the Pelton wheel does not perform any hydraulic function.

4. Breaking jet: When the nozzle is completely closed by moving the spear in the forward direction, the amount of water striking the runner reduces to zero. But the runner due to inertia goes on revolving for a long time. To stop the runner in a short time, a small nozzle is provided, which directs the jet of water on the back of the vanes. This jet of water is called

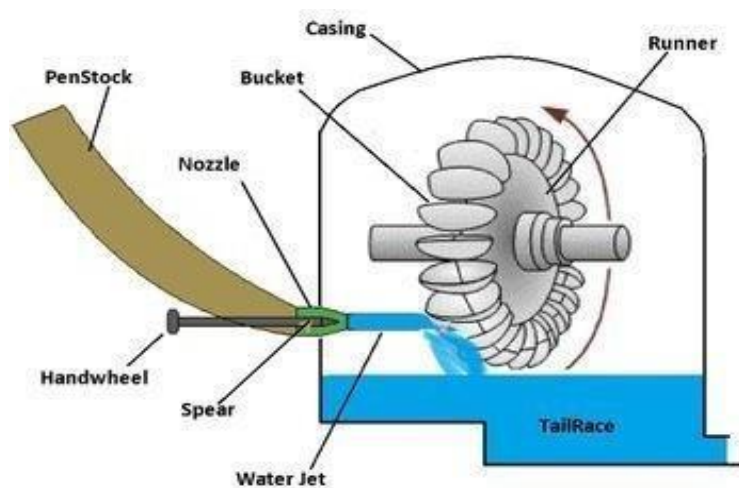

Breaking jet.

Velocity triangles and work done for Pelton wheel:

The jet of water from the nozzle strikes the bucket at the splitter, which splits up the jet into two parts. These parts of the jet, glide over the inner surfaces and come out at the outer edge. The splitter is the inlet tip and outer edge of the bucket is the outlet tip of the bucket. The inlet velocity triangle is drawn at the splitter and outer velocity triangle is drawn at the outer edge of the bucket.

Let

H = Net head acting on the Pelton Wheel

$$= H_g - h_f$$

Where H_g = Gross Head

$$h_f = \frac{4fLV^2}{D^5 \times 2g}$$

Where D = diameter of penstock,

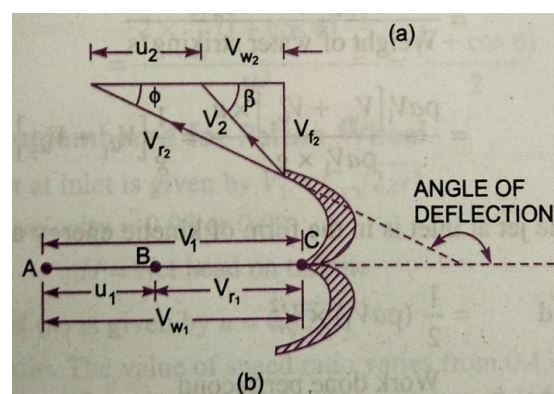

D^*

D =Diameter of wheel, d

= Diameter of Jet,

N = Speed of the wheel in r.p.m

Then V_1 =Velocity of jet at inlet

$$= \sqrt{2gH} \quad u = u_1 = u_2 = \frac{\pi DN}{60}$$

The Velocity Triangle at inlet will be a straight line where

$$V_{r_1} = V_1 - u_1 = V_1 - u$$
$$V_{w_1} = V_1 \quad \alpha = 0^\circ \quad \text{and } \theta = 0^\circ$$

From the velocity triangle at outlet, we have

$$V_{r_2} = V_2 \quad \text{and } V_{w_2} = V_{r_2} \cos \phi - u_2$$

The force exerted by the Jet of water in the direction of motion is

$$F_x = \rho a V_1 [V_{w_1} + V_{w_2}] \quad (1)$$

As the angle β is an acute angle, +ve sign should be taken. Also this is the case of series of vanes, the mass of water striking is $\rho a V_1$ and not $\rho a V_{r_2}$. In equation (1), „a“ is the area of the jet = $\frac{\pi}{4} d^2$

Now work done by the jet on the runner per second

$$= F_x \times u = \rho a V_1 [V_{w_1} + V_{w_2}] \times u \quad \text{Nm/s}$$

$$\text{Power given to the runner by the jet} = \frac{\rho a V_1 [V_{w_1} + V_{w_2}] \times u}{1000} \text{ kW}$$

Work done/s per unit weight of water striking/s

$$= \frac{\rho a V_1 [V_{w_1} + V_{w_2}] \times u}{\rho a V_1 \times g} = \frac{\rho a V_1 [V_{w_1} + V_{w_2}] \times u}{\text{Weight of water striking}} = \frac{1}{g} [V_{w_1} + V_{w_2}] \times u \quad (3)$$

The energy supplied to the jet at inlet is in the form of kinetic energy

$$\therefore \text{K.E. of jet per second} = \frac{1}{2} m V^2 = \frac{1}{2} (\rho a V_1) \times V_1^2$$

$$\therefore \text{Hydraulic efficiency, } \eta_h = \frac{\text{Work done per second}}{\text{K.E. of jet per second}}$$

$$= \frac{\rho a V_1 [V_{w_1} + V_{w_2}] \times u}{\frac{1}{2} (\rho a V_1) \times V_1^2}$$

$$= \frac{2 [V_{w_1} + V_{w_2}] \times u}{V_1^2} \quad (4)$$

Now

$$V_{w_1} = V_1 \text{ and } V_{r_1} = V_1 - u_1 = (V_1 - u)$$

∴

$$V_{r_2} = (V_1 - u)$$

And

$$V_{w_2} = V_{r_2} \cos \phi - u_2$$

$$= V_{r_2} \cos \phi - u$$

$$= (V_1 - u) \cos \phi - u$$

Substituting the values of V_{w_1} and V_{w_2} in equation (4)

$$\eta_h = \frac{2[V_1 + (V_1 - u) \cos \phi - u] \times u}{V_1^2} = \frac{2[V_1 - u + (V_1 - u) \cos \phi] \times u}{V_1^2}$$

$$= \frac{2(V_1 - u)[1 + \cos \phi] u}{V_1^2} \quad \text{----- (5)}$$

The efficiency will be maximum for a given value of V_1 when

$$\frac{d}{du} (\eta_h) = 0 \text{ or } \frac{d}{du} \left[\frac{2u(V_1 - u)[1 + \cos \phi]}{V_1^2} \right] = 0$$

$$\text{Or } \frac{(1 + \cos \phi)}{V_1^2} \frac{d}{du} (2uV_1 - 2u^2) = 0$$

$$\text{Or } \frac{d}{du} [2uV_1 - 2u^2] = 0 \quad \left(\because \frac{1 + \cos \phi}{V_1^2} \neq 0 \right)$$

$$\text{Or } 2V_1 - 4u = 0 \quad \text{Or } u = \frac{V_1}{2} \quad \text{----- (6)}$$

Equation (6) states that hydraulic efficiency of a Pelton wheel will be maximum when the velocity of the wheel is half the velocity of the jet water at inlet. The expression for maximum efficiency will be obtained by substituting the value of $u = \frac{V_1}{2}$ in equation (5)

$$\text{Max. } \eta_h = \frac{2 \left(V_1 - \frac{V_1}{2} \right) (1 + \cos \phi) \times \frac{V_1}{2}}{V_1^2}$$

$$= \frac{2 \times \frac{V_1}{2} (1 + \cos \phi) \frac{V_1}{2}}{V_1^2} = \frac{(1 + \cos \phi)}{2}$$

RADIALFLOWREACTIONTURBINE

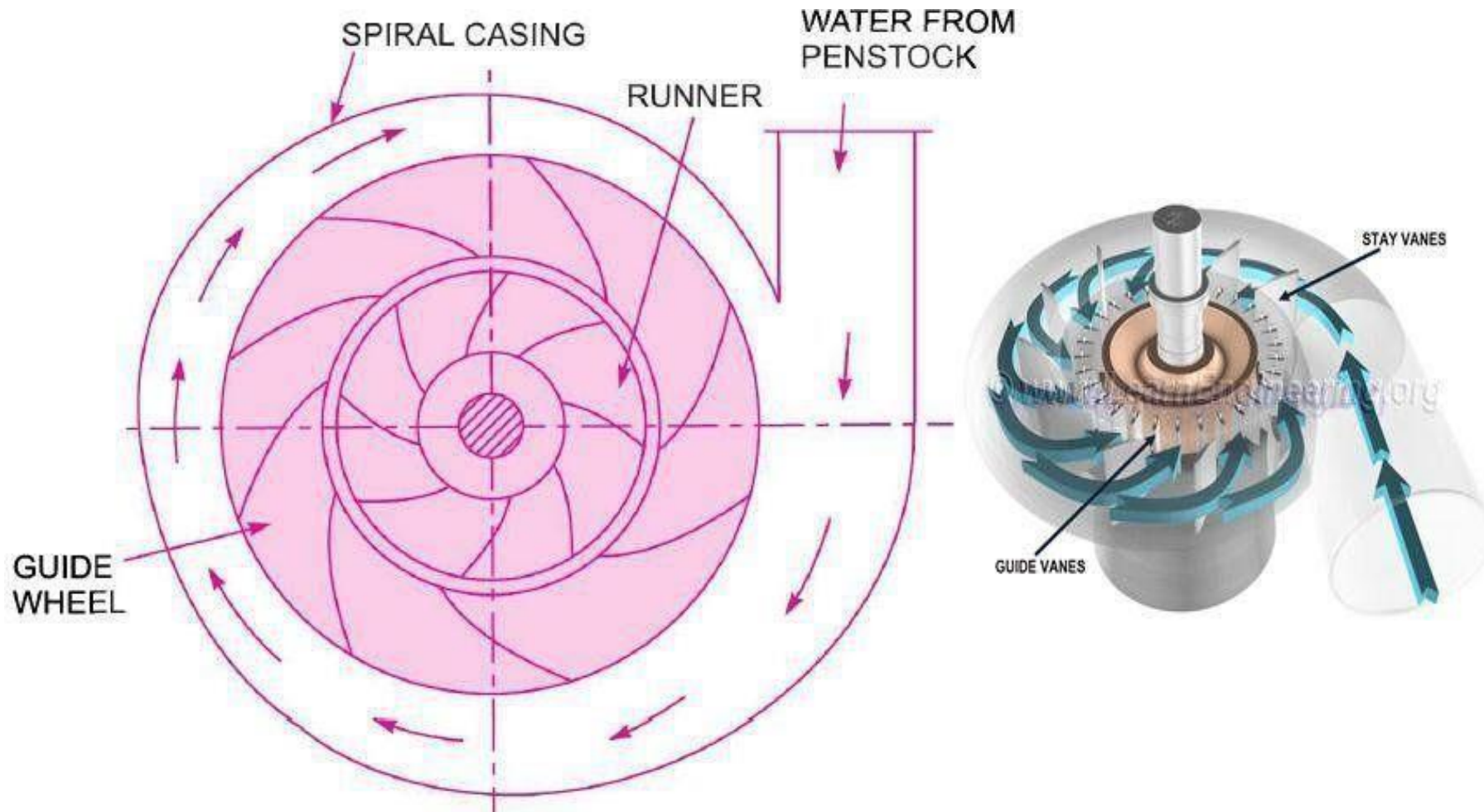

RADIALFLOWREACTIONTURBINE

Radial flow turbines are those turbines in which the water flows in the radial direction. The water may flow radially from outwards to inwards (*i.e.*, towards the axis of rotation) or from inwards to outwards. If the water flows from outwards to inwards through the runner, the turbine is known as inward radial flow turbine. And if the water flows from inwards to outwards, the turbine is known as outward radial flow turbine.

Reaction turbine means that the water at the inlet of the turbine possesses kinetic energy as well as pressure energy. As the water flows through the runner, a part of pressure energy goes on changing into kinetic energy. Thus the water through the runner is under pressure. The runner is completely enclosed in an air-tight casing and casing and the runner is always full of water.

MAINPARTSOFREACTIONTURBINE

1. Casing,
2. Guide mechanism,
3. Runner, and
4. Draft-tube.

1. Casing. As mentioned above that in case of reaction turbine, casing and runner are always full of water. The water from the penstocks enters the casing which is of spiral shape in which area of cross-section of the casing goes on decreasing gradually. The casing completely surrounds the runner of the turbine. The casing as shown in Fig. 18.10 is made of spiral shape, so that the water may enter the runner at constant velocity throughout the circumference of the runner. The casing is made of concrete, cast steel or plate steel.

2. Guide Mechanism. It consists of a stationary circular wheel all round the runner of the turbine. The stationary guide vanes are fixed on the guide mechanism. The guide vanes allow the water to strike the vanes fixed on the runner without shock at inlet. Also by a suitable arrangement, the width between two adjacent vanes of guide mechanism can be altered so that the amount of water striking the runner can be varied.

3. Runner. It is a circular wheel on which a series of radial curved vanes are fixed. The surface of the vanes are made very smooth. The radial curved vanes are so shaped that the water enters and leaves the runner without shock. The runners are made of cast steel, cast iron or stainless steel. They are keyed to the shaft.

4. Draft-tube. The pressure at the exit of the runner of a reaction turbine is generally less than atmospheric pressure. The water at exit cannot be directly discharged to the tail race. A tube or pipe of gradually increasing area is used for discharging water from the exit of the turbine to the tail race. This tube of increasing area is called draft tube.

INWARD RADIAL FLOW TURBINE

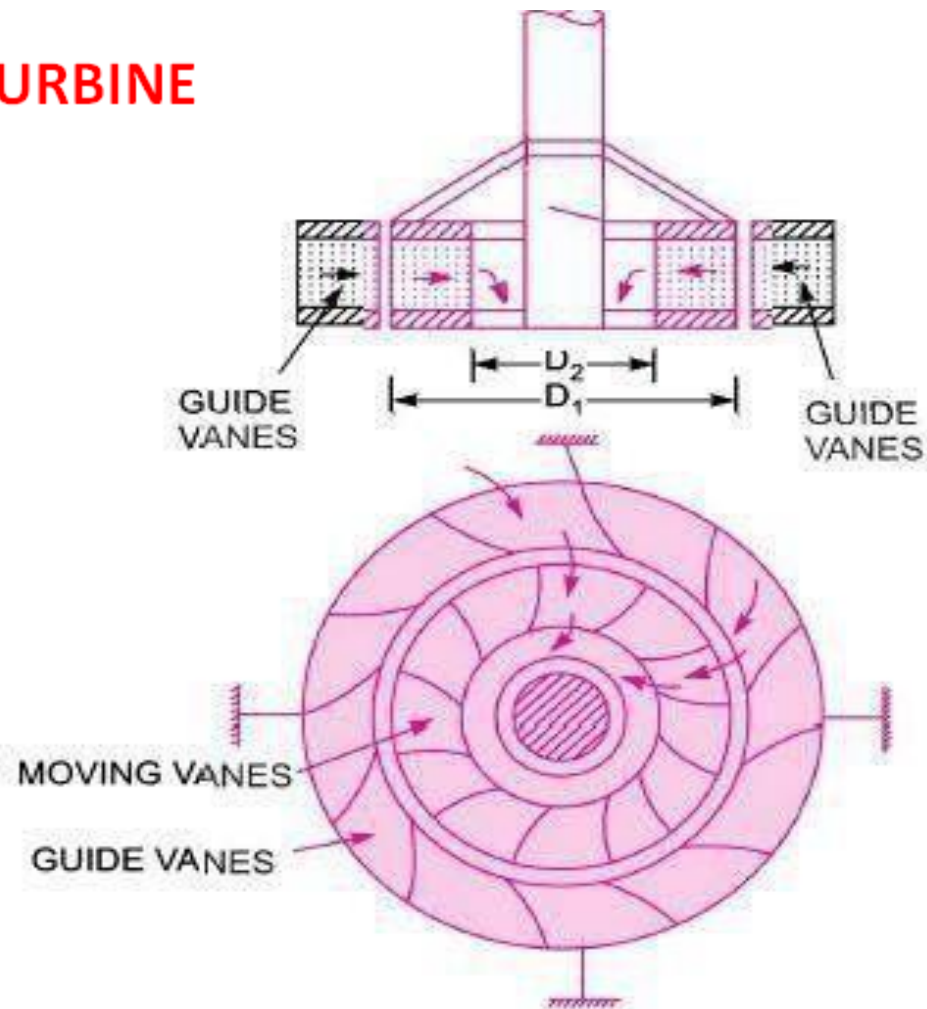

Fig. *Inward radial flow turbine.*

Inward Radial Flow Turbine. Fig. shows inward radial flow turbine, in which case the water from the casing enters the stationary guiding wheel. The guiding wheel consists of guide vanes which direct the water to enter the runner which consists of moving vanes. The water flows over the moving vanes in the inward radial direction and is discharged at the inner diameter of the runner. The outer diameter of the runner is the inlet and the inner diameter is the outlet.

VELOCITY TRIANGLE OF INWARD RADIAL FLOW TURBINE

Outlet velocity triangle

When β is acute angle
 $\beta < 90^\circ$

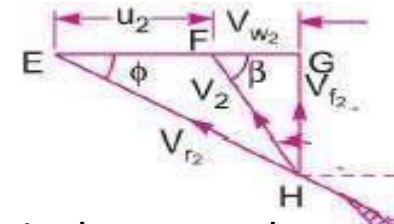

When is obtuse angle
 $\beta > 90^\circ$

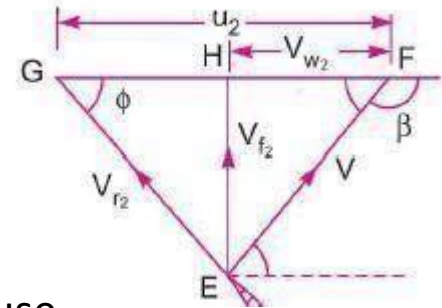

When is obtuse angle
 $\beta = 90^\circ$

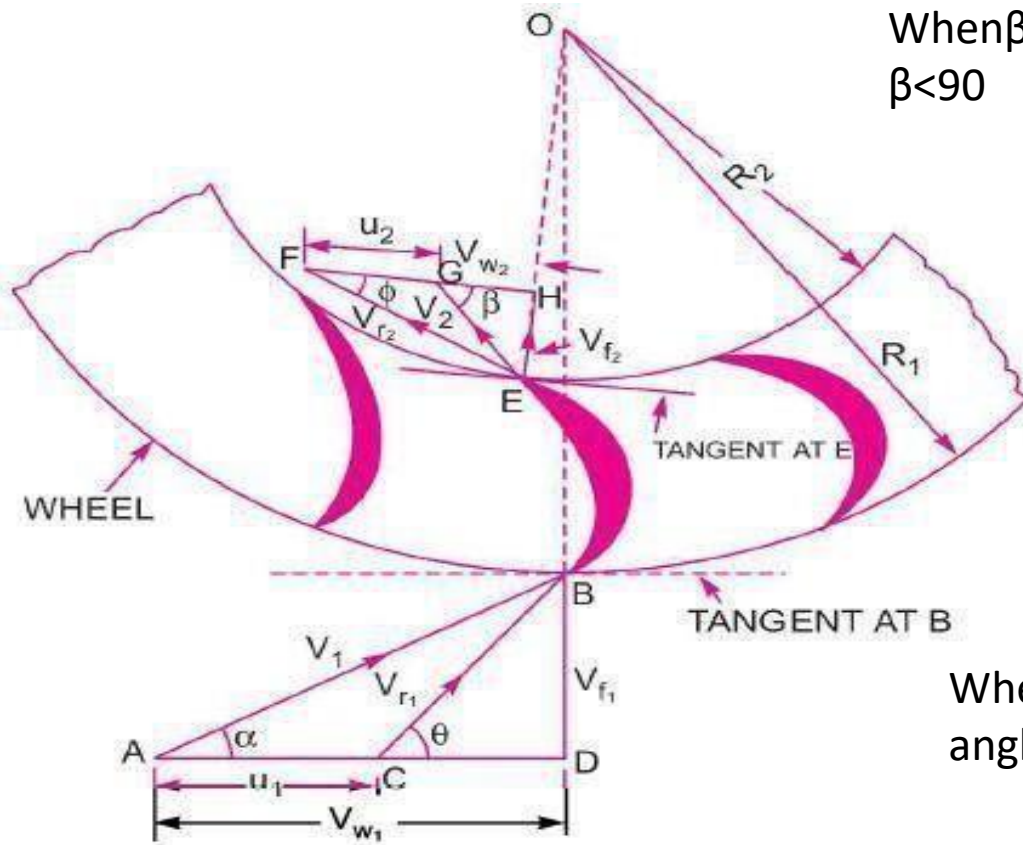
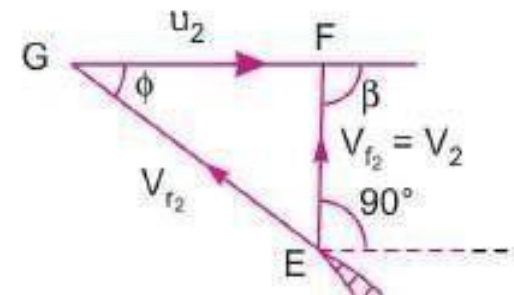

Fig.

Series of radial curved vanes mounted on a wheel

Let $R_1 =$ Radius of wheel at inlet of the vane,
 $R_2 =$ Radius of the wheel at the outlet of the vane,
 $\omega =$ Angular speed of the wheel.

Then $u_1 = \omega R_1$ and $u_2 = \omega R_2$

The velocity triangles at inlet and outlet are drawn as shown in Fig.

The mass of water striking per second for a series of vanes
 $=$ Mass of water coming out from nozzle per second
 $= \rho a V_1$, where $a =$ Area of jet and $V_1 =$ Velocity of jet.

Momentum of water striking the vanes in the tangential direction per sec at inlet
 $=$ Mass of water per second \times Component of V_1 in the tangential direction
 $= \rho a V_1 \times V_{w_1}$ (\because Component of V_1 in tangential direction $= V_1 \cos \alpha = V_{w_1}$)

Similarly, momentum of water at outlet per sec
 $= \rho a V_1 \times$ Component of V_2 in the tangential direction
 $= \rho a V_1 \times (-V_2 \cos \beta) = -\rho a V_1 \times V_{w_2}$ ($\because V_2 \cos \beta = V_{w_2}$)

-ve sign is taken as the velocity V_2 at outlet is in opposite direction.

Now, angular momentum per second at inlet
 $=$ Momentum at inlet \times Radius at inlet
 $= \rho a V_1 \times V_{w_1} \times R_1$

Angular momentum per second at outlet
 $=$ Momentum of outlet \times Radius at outlet
 $= -\rho a V_1 \times V_{w_2} \times R_2$

Torque exerted by the water on the wheel,

$$\begin{aligned}
 T &= \text{Rate of change of angular momentum} \\
 &= [\text{Initial angular momentum per second} - \text{Final angular momentum per second}] \\
 &= \rho a V_1 \times V_{w_1} \times R_1 - (-\rho a V_1 \times V_{w_2} \times R_2) = \rho a V_1 [V_{w_1} \times R_1 + V_{w_2} R_2]
 \end{aligned}$$

Work done per second on the wheel

$$\begin{aligned}
 &= \text{Torque} \times \text{Angular velocity} = T \times \omega \\
 &= \rho a V_1 [V_{w_1} \times R_1 + V_{w_2} R_2] \times \omega = \rho a V_1 [V_{w_1} \times R_1 \times \omega + V_{w_2} R_2 \times \omega] \\
 &= \rho a V_1 [V_{w_1} u_1 + V_{w_2} \times u_2] \quad (\because u_1 = \omega R_1 \text{ and } u_2 = \omega R_2)
 \end{aligned}$$

If the angle β in Fig. 17.23 is an obtuse angle then work done per second will be given as

$$= \rho a V_1 [V_{w_1} u_1 - V_{w_2} u_2]$$

\therefore The general expression for the work done per second on the wheel

$$= \rho a V_1 [V_{w_1} u_1 \pm V_{w_2} u_2] \dots\dots\dots 1$$

If the discharge is radial at outlet, then $\beta = 90^\circ$ and work done becomes as

$$= \rho a V_1 [V_{w_1} u_1] \dots\dots\dots 2 \quad (\because V_{w_2} = 0)$$

The work done per second on the runner by water is given by equation

$$\begin{aligned}
 &= \rho a V_1 [V_{w_1} u_1 \pm V_{w_2} u_2] \\
 &= \rho Q [V_{w_1} u_1 \pm V_{w_2} u_2] \quad (\because a V_1 = Q) \dots
 \end{aligned}$$

The equation also represents the energy transfer per second to the runner.

where V_{w_1} = Velocity of whirl at inlet,

V_{w_2} = Velocity of whirl at outlet,

u_1 = Tangential velocity of wheel at inlet

$$= \frac{\pi D_1 \times N}{60}, \text{ where } D_1 = \text{Outer dia. of runner,}$$

u_2 = Tangential velocity of wheel at outlet

$$= \frac{\pi D_2 \times N}{60}, \text{ where } D_2 = \text{Inner dia. of runner, } N = \text{Speed of the turbine in r.p.m.}$$

The work done per second per unit weight of water per second.

$$\begin{aligned}
 &= \frac{\text{Work done per second}}{\text{Weight of water striking per second}} \\
 &= \frac{\rho Q [V_{w_1} u_1 \pm V_{w_2} u_2]}{\rho Q \times g} = \frac{1}{g} [V_{w_1} u_1 \pm V_{w_2} u_2] \quad \dots\dots 1
 \end{aligned}$$

The equation 1 represents the energy transfer per unit weight/s to the runner. This equation is known by **Euler's equation** of hydrodynamics machines. This is also known as fundamental equation of hydrodynamic machines. This equation was given by Swiss scientist *L. Euler*.

In equation 1 +ve sign is taken if angle β is an acute angle. If β is an obtuse angle then -ve sign is taken. If $\beta = 90^\circ$, then $V_{w_2} = 0$ and work done per second per unit weight of water striking/s become as

$$= \frac{1}{g} V_{w_1} u_1 \dots\dots\dots 2$$

Hydraulic efficiency is obtained from equation (18.2) as

$$\eta_h = \frac{\text{R.P.}}{\text{W.P.}} = \frac{\frac{W}{1000g} [V_{w_1} u_1 \pm V_{w_2} u_2]}{\frac{W \times H}{1000}} = \frac{(V_{w_1} u_1 \pm V_{w_2} u_2)}{gH} \dots\dots\dots 3$$

where R.P. = Runner power *i.e.*, power delivered by water to the runner

W.P. = Water power

If the discharge is radial at outlet, then $V_{w_2} = 0$

$$\eta_h = \frac{V_{w_1} u_1}{gH} \dots\dots\dots 4$$

Definitions. The following terms are generally used in case of reaction radial flow turbines which are defined as :

(i) **Speed Ratio.** The speed ratio is defined as $= \frac{u_1}{\sqrt{2gH}}$
where u_1 = Tangential velocity of wheel at inlet.

(ii) **Flow Ratio.** The ratio of the velocity of flow at inlet (V_{f_1}) to the velocity given $\sqrt{2gH}$ is known as flow ratio or it is given as

$$= \frac{V_{f_1}}{\sqrt{2gH}}, \text{ where } H = \text{Head on turbine}$$

(iii) **Discharge of the Turbine.** The discharge through a reaction radial flow turbine is given by

$$Q = \pi D_1 B_1 \times V_{f_1} = \pi D_2 \times B_2 \times V_{f_2}$$

where D_1 = Diameter of runner at inlet,
 B_1 = Width of runner at inlet,
 V_{f_1} = Velocity of flow at inlet, and

D_2, B_2, V_{f_2} = Corresponding values at outlet.

If the thickness of vanes are taken into consideration, then the area through which flow takes place is given by $(\pi D_1 - n \times t)$

where n = Number of vanes on runner and t = Thickness of each vane

The discharge Q , then is given by $Q = (\pi D_1 - n \times t) B_1 \times V_{f_1}$

(iv) The head (H) on the turbine is given by $H = \frac{p_1}{\rho \times g} + \frac{V_1^2}{2g}$

where p_1 = Pressure at inlet.

(v) **Radial Discharge.** This means the angle made by absolute velocity with the tangent on the wheel is 90° and the component of the whirl velocity is zero. Radial discharge at outlet means $\beta = 90^\circ$ and $V_{w_2} = 0$, while radial discharge at inlet means $\alpha = 90^\circ$ and $V_{w_1} = 0$.

(vi) If there is no loss of energy when water flows through the vanes then we have

$$H - \frac{V_2^2}{2g} = \frac{1}{g} [V_{w_1} u_1 \pm V_{w_2} u_2].$$

Francisturbine

- ❑ As names suggest, this is a type of reaction turbine which is developed by an American engineer, Sir J.B. Francis.
- ❑ Francis turbine is basically an inward flow reaction turbine with radial discharge at its outlet.
- ❑ In modern Francis turbine, the water will enter the runner of the turbine in the radial direction at outlet and will leave in the axial direction at the inlet of the runner. Therefore, the modern Francis turbine will be termed as mixed flow turbine.

Francisturbine

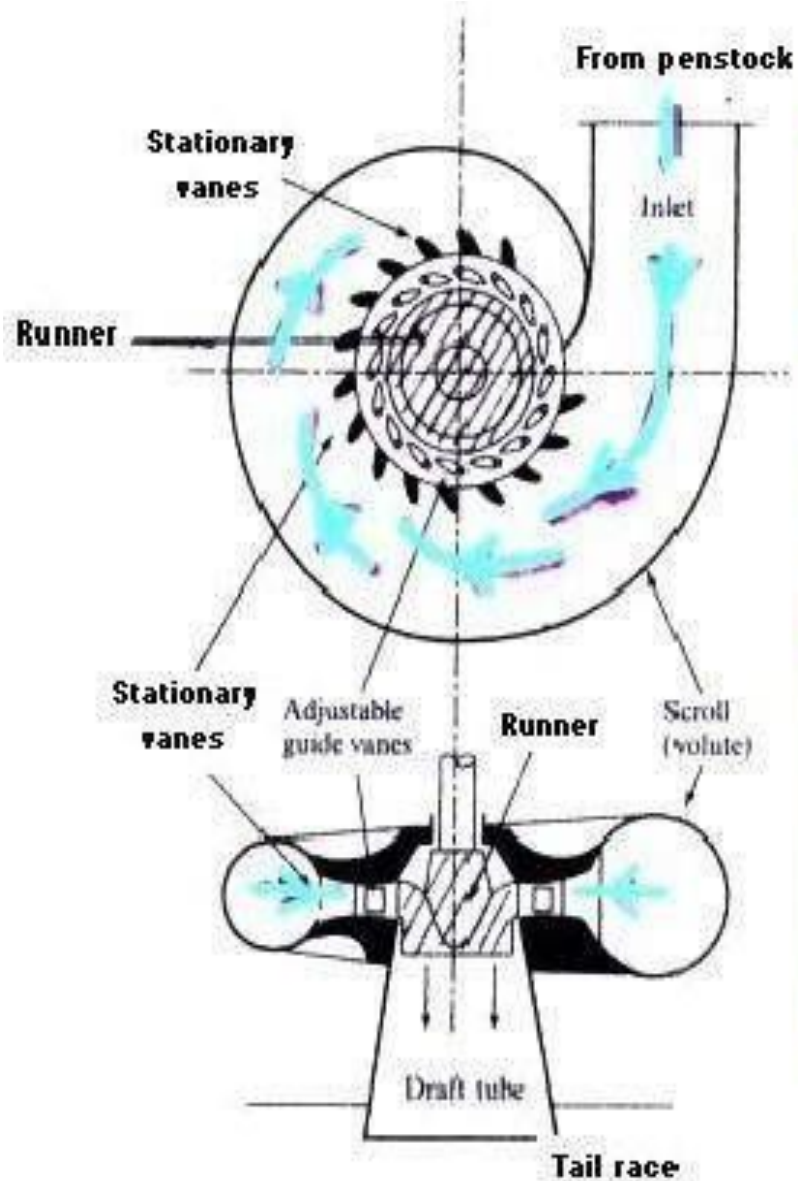

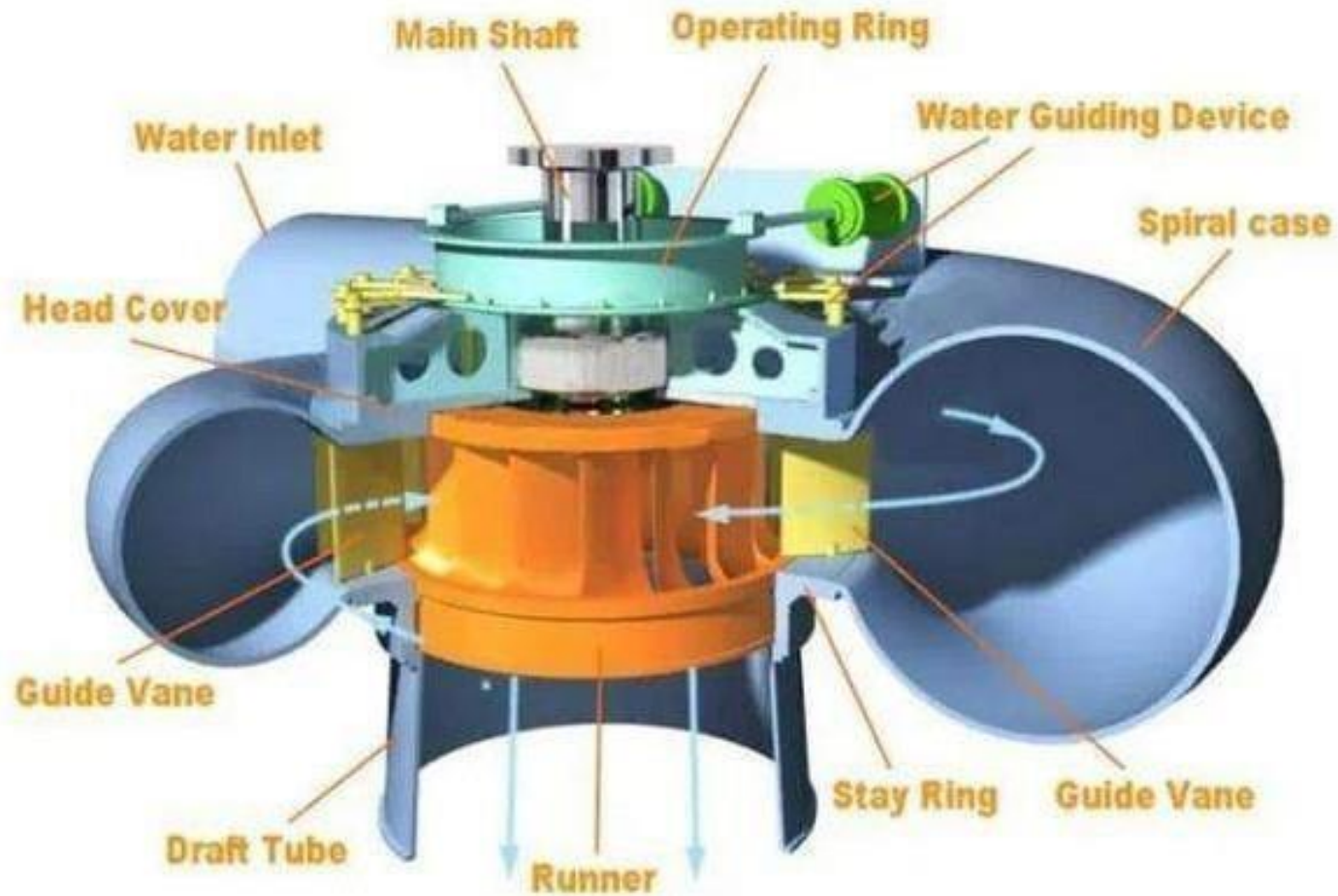

Francis Turbine

Francisturbine

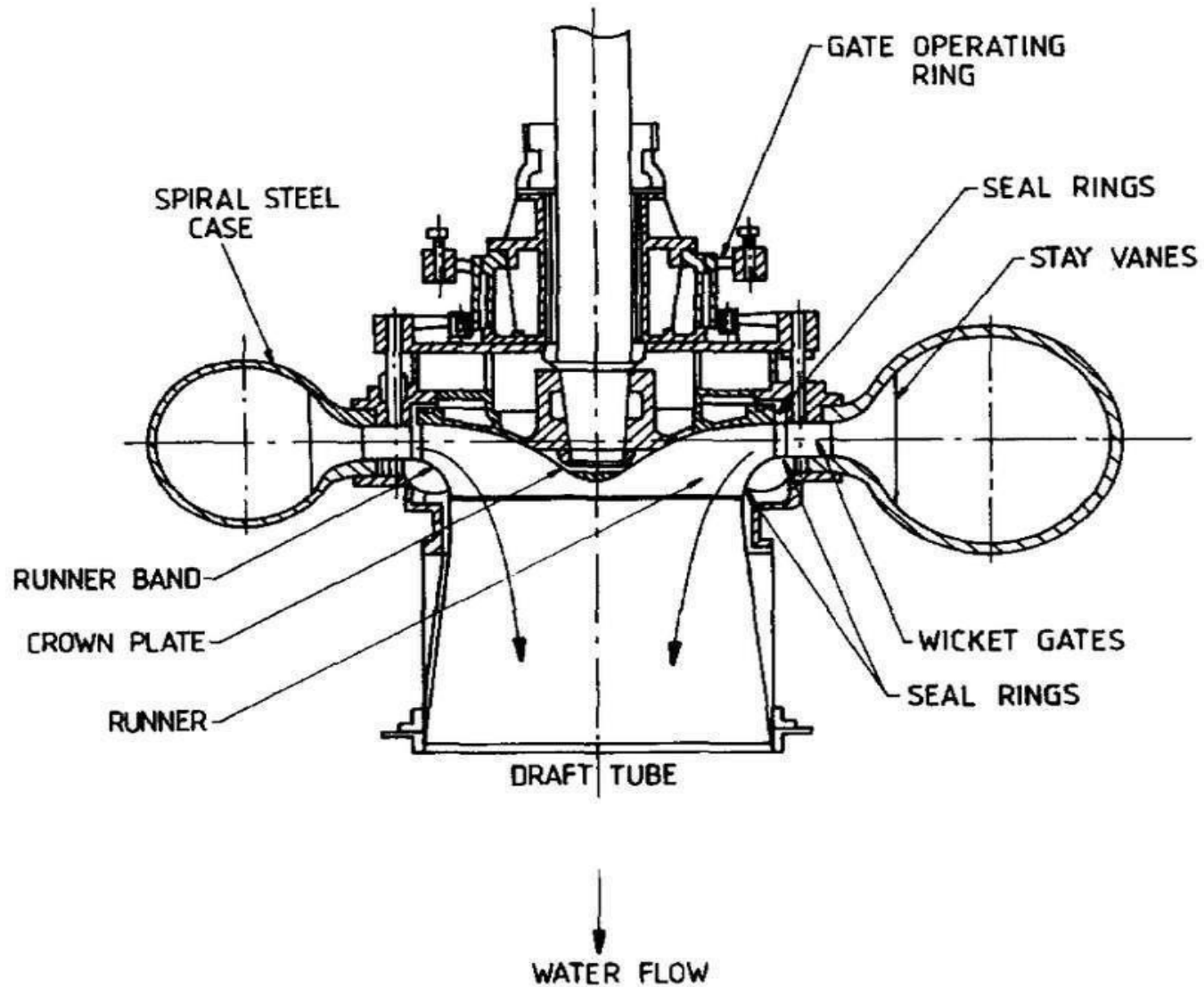



Francisturbine

Francisturbine



PARTSOFFRANCISTURBINE

Spiral casing: The spiral casing around the runner of the turbine is known as the volute casing or scroll case. Throughout its length, it has numerous openings at regular intervals to allow the working fluid to impinge on the blades of the runner. These openings convert the pressure energy of the fluid into kinetic energy just before the fluid impinges on the blades. This maintains a constant velocity despite the fact that numerous openings have been provided for the fluid to enter the blades, as the cross-sectional area of this casing decreases uniformly along the circumference.

Guide and stay vanes: The primary function of the guide and stay vanes is to convert the pressure energy of the fluid into kinetic energy. It also serves to direct the flow at design angles to the runner blades.

Runner blades: Runner blades are the heart of any turbine. These are the centers where the fluid strikes and the tangential force of the impact causes the shaft of the turbine to rotate, producing torque. Close attention to design of blade angles at inlet and outlet is necessary, as these are major parameters affecting power production.

Draft tube: The draft tube is a conduit that connects the runner exit to the tail race where the water is discharged from the turbine. Its primary function is to reduce the velocity of discharged water to minimize the loss of kinetic energy at the outlet. This permits the turbine to be set above the tail water without appreciable drop of available head.

VELOCITY TRIANGLE AND WORK DONE OF FRANCIS TURBINE

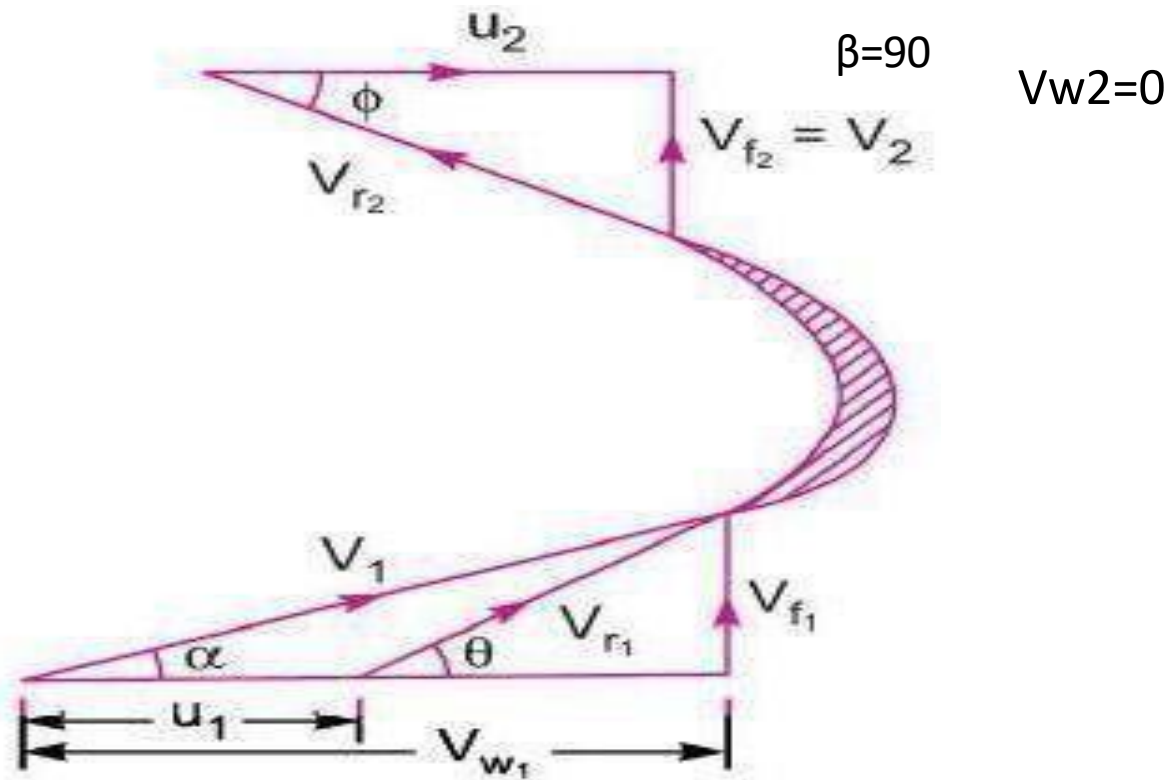

Velocity triangle of francis turbine

The velocity triangle at inlet and outlet of the Francis turbine are drawn in the same way as in case of inward flow reaction turbine. As in case of Francis turbine, the discharge is radial at outlet, the velocity of whirl at outlet (*i.e.*, V_{w_2}) will be zero. Hence the work done by water on the runner per second will be

$$= \rho Q [V_{w_1} u_1]$$

And work done per second per unit weight of water striking/s = $\frac{1}{g} [V_{w_1} u_1]$

Hydraulic efficiency will be given by, $\eta_h = \frac{V_{w_1} u_1}{gH}$.

Important Relations for Francis Turbines. The following are the important relations for Francis Turbines :

1. The ratio of width of the wheel to its diameter is given as $n = \frac{B_1}{D_1}$. The value of n varies from 0.10 to .40.

2. The flow ratio is given as,

Flow ratio = $\frac{V_{f_1}}{\sqrt{2gH}}$ and varies from 0.15 to 0.30.

3. The speed ratio = $\frac{u_1}{\sqrt{2gH}}$ varies from 0.6 to 0.9.

PROBLEM 1

A Francis turbine with an overall efficiency of 75% is required to produce 148.25 kW power. It is working under a head of 7.62 m. The peripheral velocity = $0.26 \sqrt{2gH}$ and the radial velocity of flow at inlet is $0.96 \sqrt{2gH}$. The wheel runs at 150 r.p.m. and the hydraulic losses in the turbine are 22% of the available energy. Assuming radial discharge, determine :

- (i) The guide blade angle, (ii) The wheel vane angle at inlet,
 (iii) Diameter of the wheel at inlet, and (iv) Width of the wheel at inlet.

Solution. Given :

Overall efficiency $\eta_o = 75\% = 0.75$

Power produced, S.P. = 148.25 kW

Head, $H = 7.62$ m

Peripheral velocity, $u_1 = 0.26 \sqrt{2gH} = 0.26 \times \sqrt{2 \times 9.81 \times 7.62} = 3.179$ m/s

Velocity of flow at inlet, $V_{f_1} = 0.96 \sqrt{2gH} = 0.96 \times \sqrt{2 \times 9.81 \times 7.62} = 11.738$ m/s.

Speed, $N = 150$ r.p.m.

Hydraulic losses = 22% of available energy

Discharge at outlet = Radial

$$V_{w_2} = 0 \text{ and } V_{f_2} = V_2$$

Hydraulic efficiency is given as

$$\eta_h = \frac{\text{Total head at inlet} - \text{Hydraulic loss}}{\text{Head at inlet}} = \frac{H - .22 H}{H} = \frac{0.78 H}{H} = 0.78$$

But

$$\eta_h = \frac{V_{w_1} u_1}{gH}$$

\therefore

$$\frac{V_{w_1} u_1}{gH} = 0.78$$

\therefore

$$\begin{aligned} V_{w_1} &= \frac{0.78 \times g \times H}{u_1} \\ &= \frac{0.78 \times 9.81 \times 7.62}{3.179} = 18.34 \text{ m/s.} \end{aligned}$$

(i) The guide blade angle, i.e., α . From inlet velocity triangle,

$$\tan \alpha = \frac{V_{f_1}}{V_{w_1}} = \frac{11.738}{18.34} = 0.64$$

\therefore

$$\alpha = \tan^{-1} 0.64 = 32.619^\circ \text{ or } 32^\circ 37'. \text{ Ans.}$$

(ii) The wheel vane angle at inlet, i.e., θ

$$\tan \theta = \frac{V_{f_1}}{V_{w_1} - u_1} = \frac{11.738}{18.34 - 3.179} = 0.774$$

\therefore

$$\theta = \tan^{-1} .774 = 37.74 \text{ or } 37^\circ 44.4'. \text{ Ans.}$$

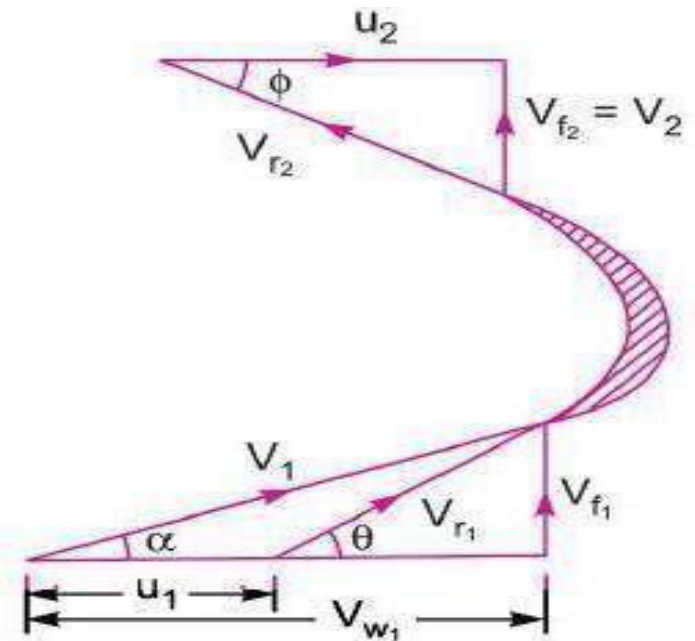

(iii) Diameter of wheel at inlet (D_1).

Using the relation,
$$u_1 = \frac{\pi D_1 N}{60}$$

$$D_1 = \frac{60 \times u_1}{\pi \times N} = \frac{60 \times 3.179}{\pi \times 50} = \mathbf{0.4047 \text{ m. Ans.}}$$

(iv) Width of the wheel at inlet (B_1)

$$\eta_o = \frac{\text{S.P.}}{\text{W.P.}} = \frac{148.25}{\text{W.P.}}$$

But
$$\text{W.P.} = \frac{WH}{1000} = \frac{\rho \times g \times Q \times H}{1000} = \frac{1000 \times 9.81 \times Q \times 7.62}{1000}$$

$$\therefore \eta_o = \frac{148.25}{\frac{1000 \times 9.81 \times Q \times 7.62}{1000}} = \frac{148.25 \times 1000}{1000 \times 9.81 \times Q \times 7.62}$$

or
$$Q = \frac{148.25 \times 1000}{1000 \times 9.81 \times 7.62 \times \eta_o} = \frac{148.25 \times 1000}{1000 \times 9.81 \times 7.62 \times 0.75} = 2.644 \text{ m}^3/\text{s}$$

$$Q = \pi D_1 \times B_1 \times V_{f1}$$

$$2.644 = \pi \times .4047 \times B_1 \times 11.738$$

$$B_1 = \frac{2.644}{\pi \times .4047 \times 11.738} = \mathbf{0.177 \text{ m. Ans.}}$$

OUTWARD FLOW REACTION TURBINE

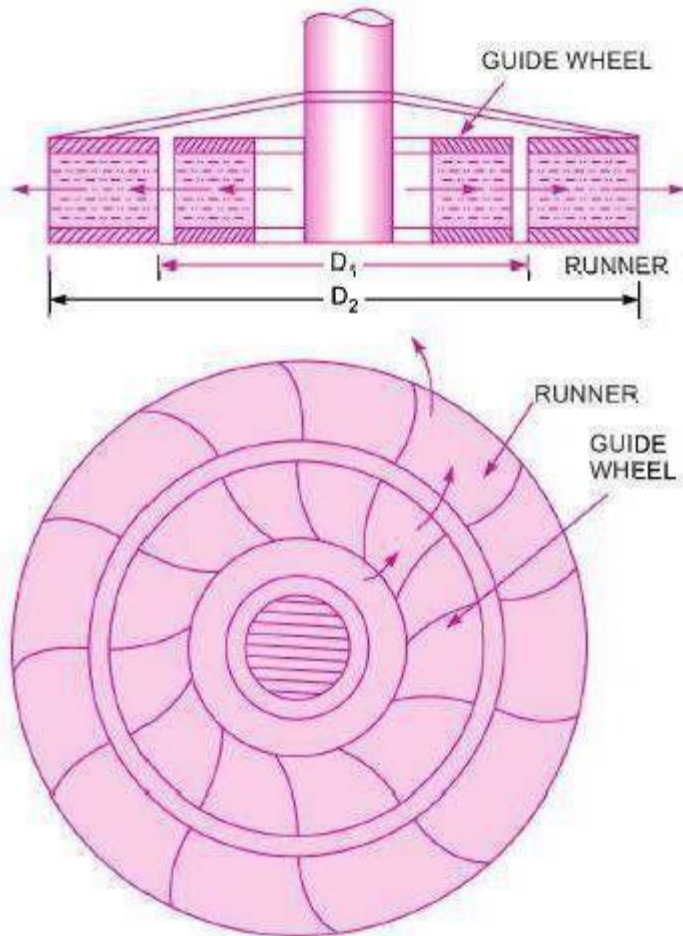

Outward Radial Flow Reaction Turbine. Fig. . . . shows outward radial flow reaction turbine in which the water from casing enters the stationary guide wheel. The guide wheel consists of guide

vanes which direct water to enter the runner which is around the stationary guide wheel. The water flows through the vanes of the runner in the outward radial direction and is discharged at the outer diameter of the runner. The inner diameter of the runner is inlet and outer diameter is the outlet.

The velocity triangles at inlet and outlet will be drawn by the same procedure as adopted for inward flow turbine. The work done by the water on the runner per second, the horse power developed and hydraulic efficiency will be obtained from the velocity triangles. In this case as inlet of the runner is at the inner diameter of the runner, the tangential velocity at inlet will be less than that of at outlet, *i.e.*,

$$u_1 < u_2 \text{ as } D_1 < D_2.$$

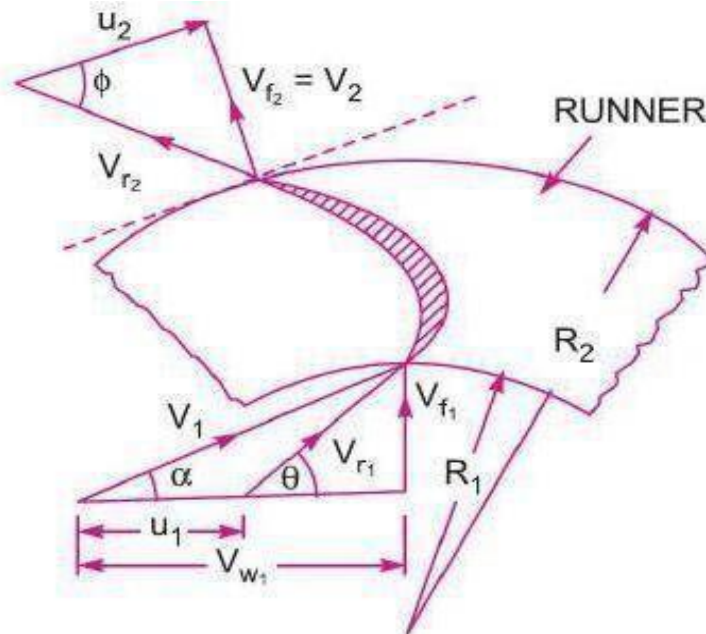

**AXIALFLOW
TURBINE
(KAPLANTURBINE)**

AXIALFLOWTURBINE

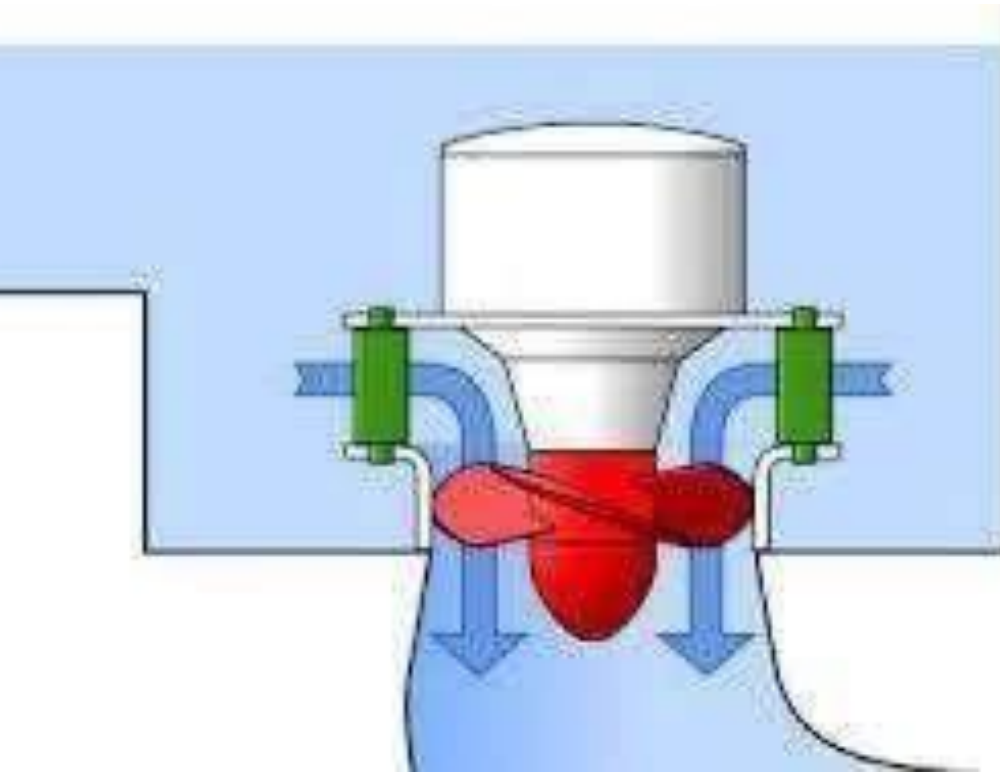

KAPLANTURBINE

If the water flows parallel to the axis of the rotation of the shaft, the turbine is known as axial flow turbine. And if the head at the inlet of the turbine is the sum of pressure energy and kinetic energy and during the flow of water through runner a part of pressure energy is converted into kinetic energy, the turbine is known as reaction turbine.

For the axial flow reaction turbine, the shaft of the turbine is vertical. The lower end of the shaft is made larger which is known as 'hub' or 'boss'. The vanes are fixed on the hub and hence hub acts as a runner for axial flow reaction turbine. The following are the important type of axial flow reaction turbines :

1. Propeller Turbine, and

2. Kaplan Turbine.

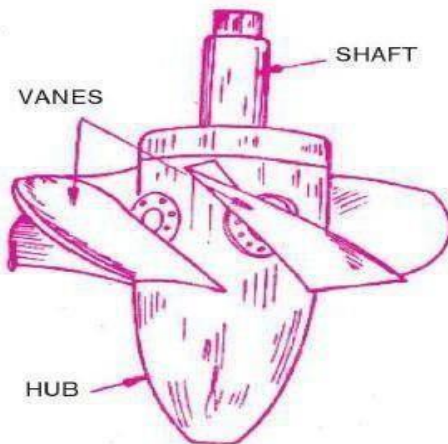

Kaplan turbine runner.

When the vanes are fixed to the hub and they are not adjustable, the turbine is known as propeller turbine. But if the vanes on the hub are adjustable, the turbine is known as a *Kaplan Turbine*, after the name of V Kaplan, an Austrian Engineer. This turbine is suitable where a large quantity of water at low head is available. Fig. shows the runner of a Kaplan turbine, which consists of a hub fixed to the shaft. On the hub, the adjustable vanes are fixed as shown in Fig.

Main parts of Kaplan turbine

1. Scroll casing,
2. Guide vanes mechanism,
3. Hub with vanes or runner of the turbine, and
4. Draft tube.

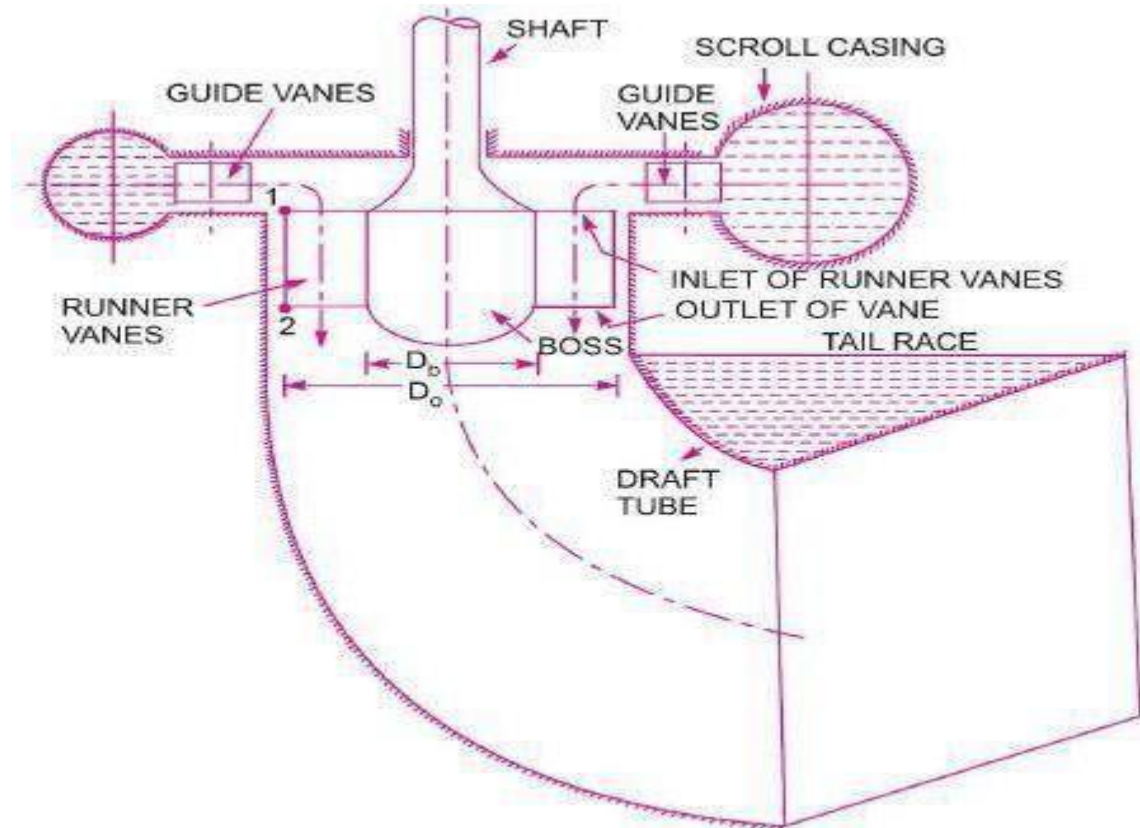

Main components of Kaplan turbine.

Fig. . . . shows all main parts of a Kaplan turbine. The water from penstock enters the scroll casing and then moves to the guide vanes. From the guide vanes, the water turns through 90° and flows axially through the runner as shown in Fig. . . . The discharge through the runner is obtained as

$$Q = \frac{\pi}{4}(D_o^2 - D_b^2) \times V_{f1}$$

where D_o = Outer diameter of the runner,

D_b = Diameter of hub, and

V_{f1} = Velocity of flow at inlet.

Some Important Point for Propeller (Kaplan Turbine). The following are the important points for propeller or Kaplan turbine :

1. The peripheral velocity at inlet and outlet are equal

$$\therefore u_1 = u_2 = \frac{\pi D_o N}{60}, \text{ where } D_o = \text{Outer dia. of runner}$$

2. Velocity of flow at inlet and outlet are equal

$$\therefore V_{f1} = V_{f2}$$

3. Area of flow at inlet = Area of flow at outlet

$$= \frac{\pi}{4}(D_o^2 - D_b^2)$$

VELOCITY TRIANGLE OF KAPLAN TURBINE

The inlet and outlet velocity triangles are drawn at the extreme edge of the runner vane corresponding to the points 1 and 2 as shown in Fig.

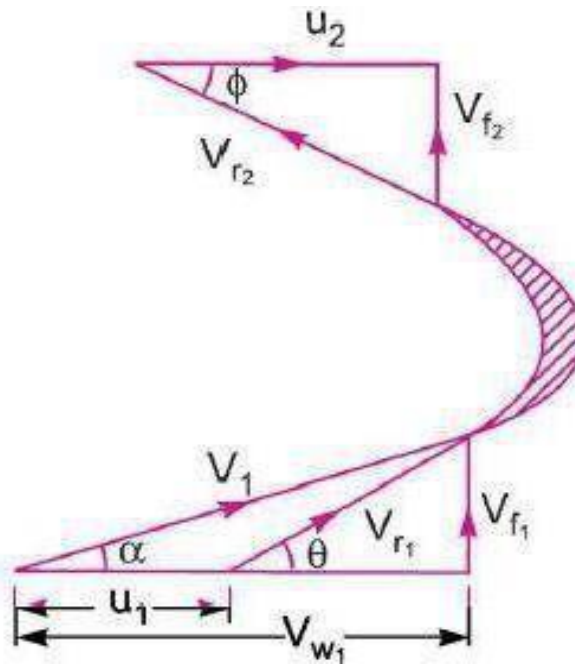

DRAFTTUBE

The draft-tube is a pipe of gradually increasing area which connects the outlet of the runner to the tail race. It is used for discharging water from the exit of the turbine to the tail race. This pipe of gradually increasing area is called a draft-tube. One end of the draft-tube is connected to the outlet of the runner while the other end is sub-merged below the level of water in the tail race. The draft-tube, in addition to serve a passage for water discharge, has the following two purposes also :

1. It permits a negative head to be established at the outlet of the runner and thereby increase the net head on the turbine. The turbine may be placed above the tail race without any loss of net head and hence turbine may be inspected properly.
2. It converts a large proportion of the kinetic energy ($V_2^2/2g$) rejected at the outlet of the turbine into useful pressure energy. Without the draft tube, the kinetic energy rejected at the outlet of the turbine will go waste to the tail race.

Hence by using draft-tube, the net head on the turbine increases. The turbine develops more power and also the efficiency of the turbine increases.

If a reaction turbine is not fitted with a draft-tube, the pressure at the outlet of the runner will be equal to atmospheric pressure. The water from the outlet of the runner will discharge freely into the tail race. The net head on the turbine will be less than that of a reaction turbine fitted with a draft-tube.

TYPES OF DRAFT TUBE

1. Conical draft-tubes,
2. Simple elbow tubes,
3. Moody spreading tubes, and
4. Elbow draft-tubes with circular inlet and rectangular outlet.

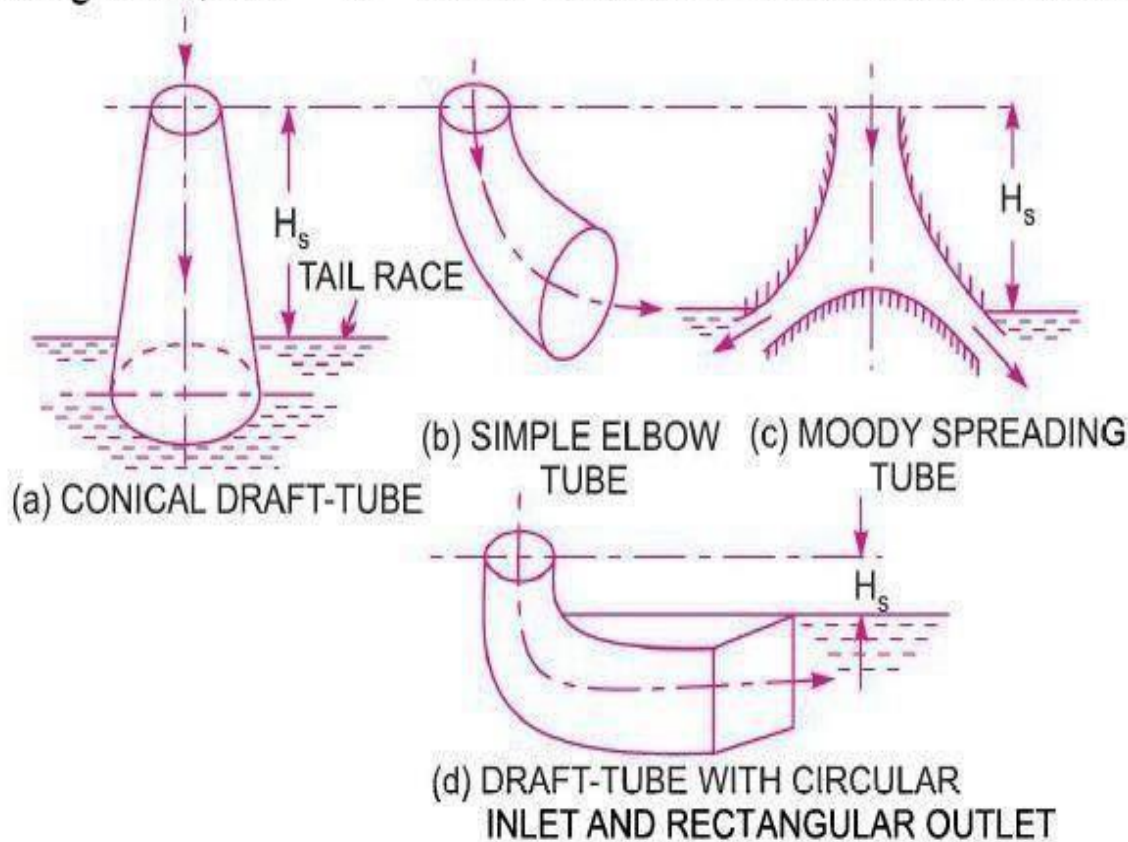

CENTRIFUGALPUM P

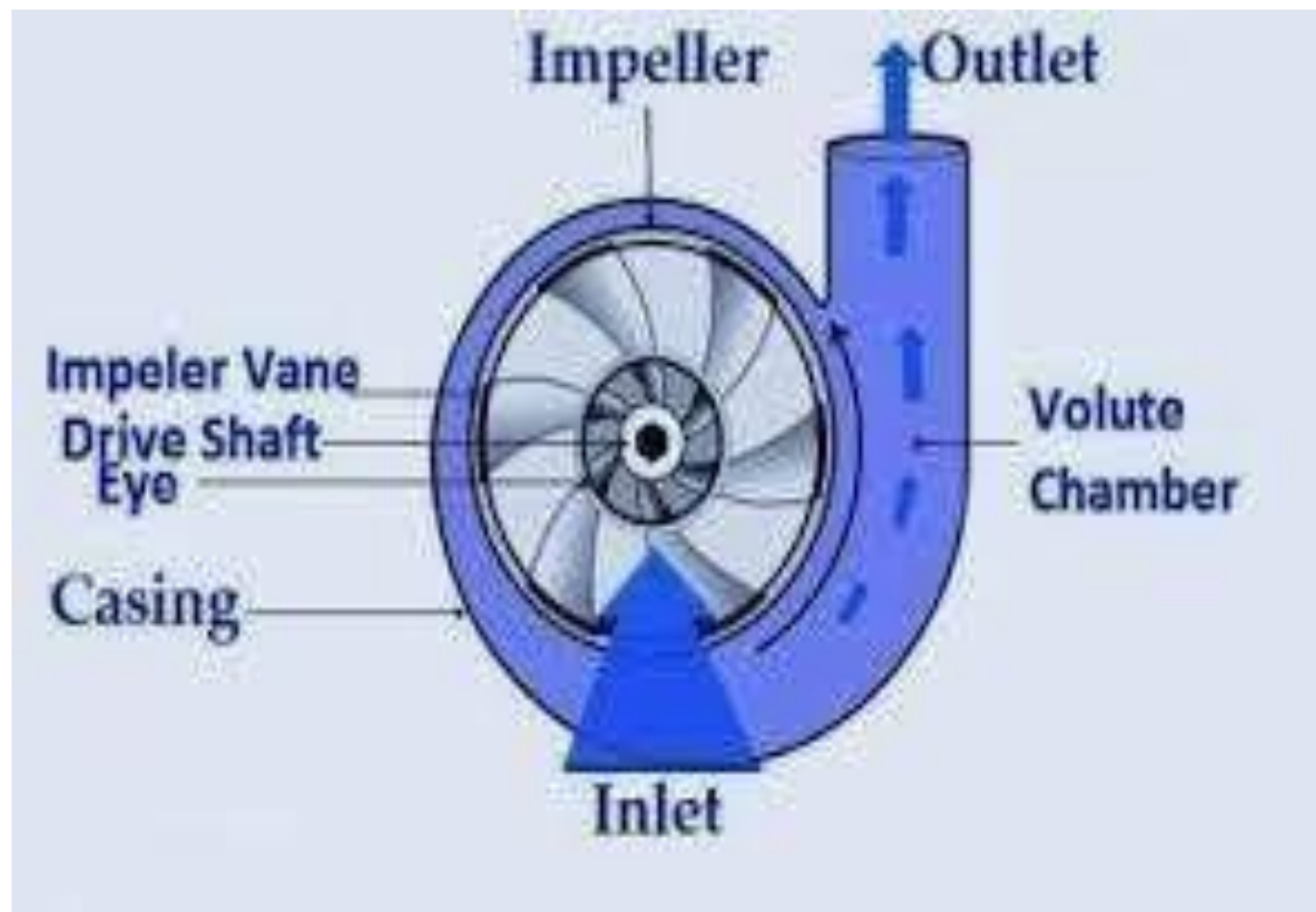



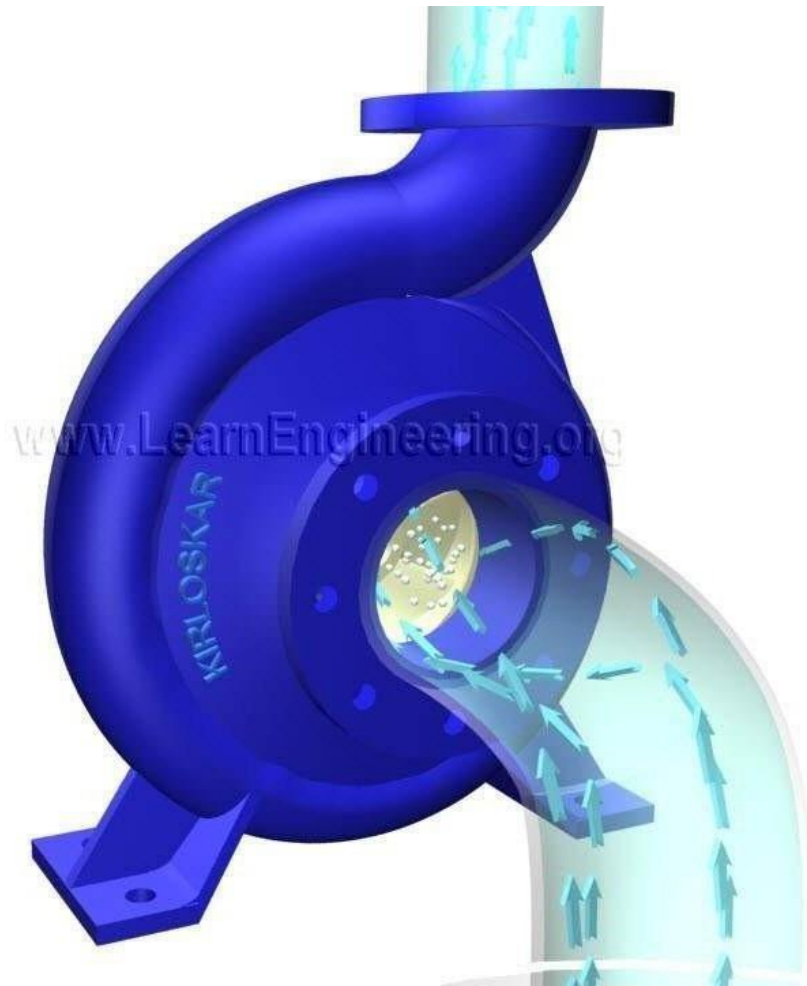

www.LearnEngineering.org

www.LearnEngineering.org

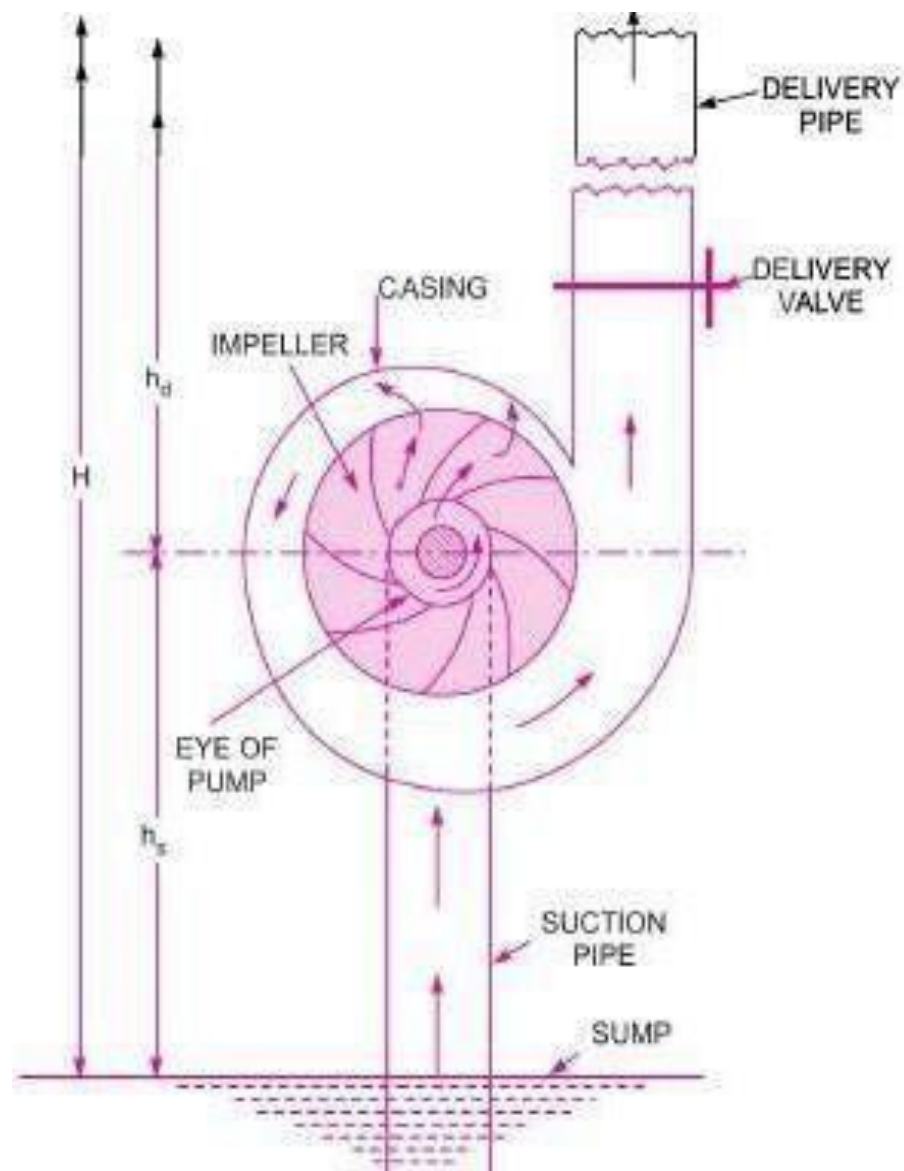

The hydraulic machines which convert the mechanical energy into hydraulic energy are called pumps. The hydraulic energy is in the form of pressure energy. If the mechanical energy is converted into pressure energy by means of centrifugal force acting on the fluid, the hydraulic machine is called centrifugal pump.

The centrifugal pump acts as a reverse of an inward radial flow reaction turbine. This means that the flow in centrifugal pumps is in the radial outward directions. The centrifugal pump works on the principle of forced vortex flow which means that when a certain mass of liquid is rotated by an external torque, the rise in pressure head of the rotating liquid takes place. The rise in pressure head at any point of the rotating liquid is proportional to the square of tangential velocity of the liquid at that point $\left(i.e., \text{rise in pressure head} = \frac{V^2}{2g} \text{ or } \frac{\omega^2 r^2}{2g} \right)$. Thus at the outlet of the impeller, where radius is more, the rise in pressure head will be more and the liquid will be discharged at the outlet with a high pressure head. Due to this high pressure head, the liquid can be lifted to a high level.

MAINPARTSOFCENTRIFUGALPUMP

The following are the main parts of a centrifugal pump :

1. Impeller.
2. Casing.
3. Suction pipe with a foot valve and a strainer.
4. Delivery pipe.

All the main parts of the centrifugal pump are shown in Fig.

1. Impeller. The rotating part of a centrifugal pump is called 'impeller'. It consists of a series of backward curved vanes. The impeller is mounted on a shaft which is connected to the shaft of an electric motor.

2. Casing. The casing of a centrifugal pump is similar to the casing of a reaction turbine. It is an air-tight passage surrounding the impeller and is designed in such a way that the kinetic energy of the water discharged at the outlet of the impeller is converted into pressure energy before the water leaves the casing and enters the delivery pipe. The following three types of the casings are commonly adopted :

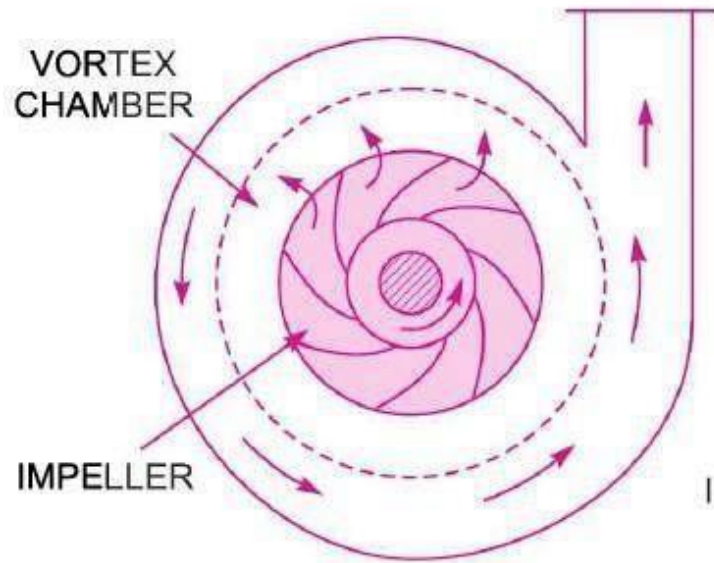

(a) VORTEX CASING

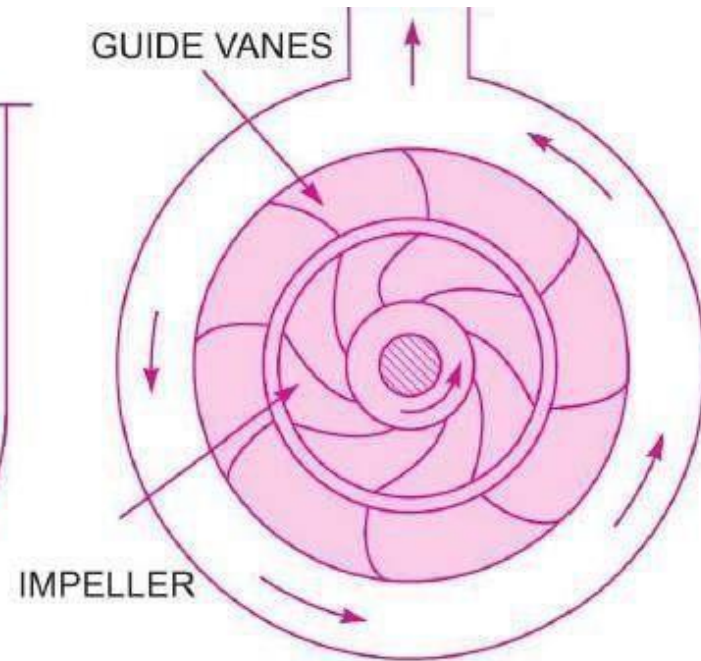

(b) CASING WITH GUIDE BLADES

(b) Vortex Casing. If a circular chamber is introduced between the casing and the impeller as shown in Fig. (a), the casing is known as Vortex Casing. By introducing the circular chamber, the loss of energy due to the formation of eddies is reduced to a considerable extent. Thus the efficiency of the pump is more than the efficiency when only volute casing is provided.

(c) Casing with Guide Blades. This casing is shown in Fig. (b) in which the impeller is surrounded by a series of guide blades mounted on a ring which is known as diffuser. The guide vanes are designed in such a way that the water from the impeller enters the guide vanes without stock.

Also the area of the guide vanes increases, thus reducing the velocity of flow through guide vanes and consequently increasing the pressure of water. The water from the guide vanes then passes through the surrounding casing which is in most of the cases concentric with the impeller as shown in Fig. (b).

3. Suction Pipe with a Foot valve and a Strainer. A pipe whose one end is connected to the inlet of the pump and other end dips into water in a sump is known as suction pipe. A foot valve which is a non-return valve or one-way type of valve is fitted at the lower end of the suction pipe. The foot valve opens only in the upward direction. A strainer is also fitted at the lower end of the suction pipe.

4. Delivery Pipe. A pipe whose one end is connected to the outlet of the pump and other end delivers the water at a required height is known as delivery pipe.

WORK DONE AND VELOCITY TRIANGLE CENTRIFUGAL PUMP

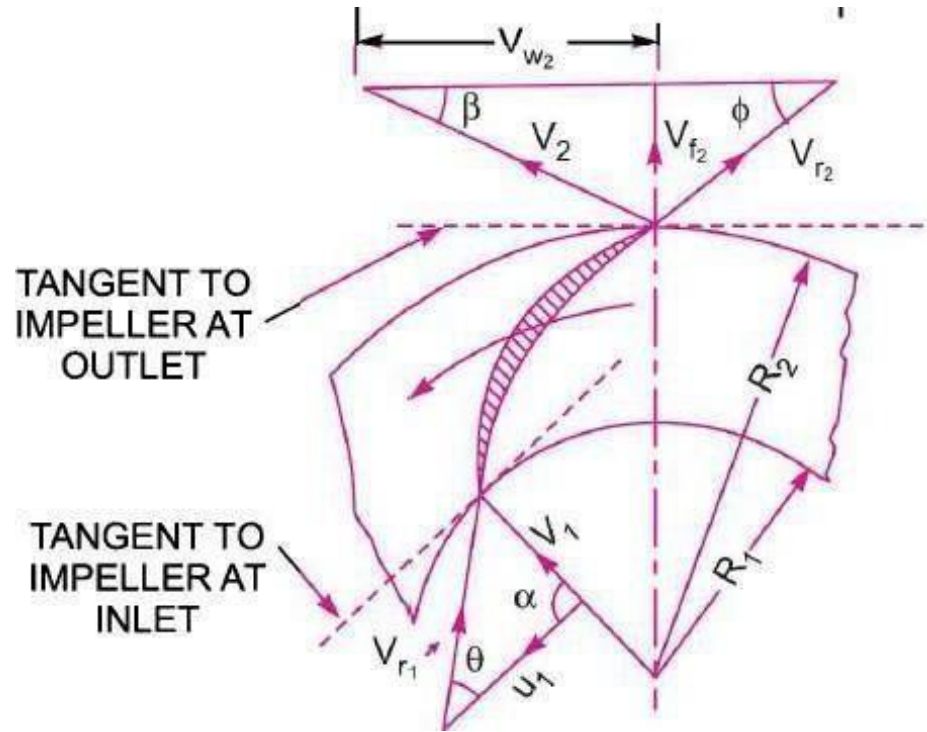

In case of the centrifugal pump, work is done by the impeller on the water. The expression for the work done by the impeller on the water is obtained by drawing velocity triangles at inlet and outlet of the impeller in the same way as for a turbine. The water enters the impeller radially at inlet for best efficiency of the pump, which means the absolute velocity of water at inlet makes an angle of 90° with the direction of motion of the impeller at inlet. Hence angle $\alpha = 90^\circ$ and $V_{w_1} = 0$. For drawing the velocity triangles, the same notations are used as that for turbines.

Let N = Speed of the impeller in r.p.m.,

D_1 = Diameter of impeller at inlet,

u_1 = Tangential velocity of impeller at inlet,

$$= \frac{\pi D_1 N}{60}$$

D_2 = Diameter of impeller at outlet,

u_2 = Tangential velocity of impeller at outlet

$$= \frac{\pi D_2 N}{60}$$

V_1 = Absolute velocity of water at inlet,

V_{r_1} = Relative velocity of water at inlet,

α = Angle made by absolute velocity (V_1) at inlet with the direction of motion of vane,

θ = Angle made by relative velocity (V_{r_1}) at inlet with the direction of motion of vane, and V_2 ,

As the water enters the impeller radially which means the absolute velocity of water at inlet is in the radial direction and hence angle $\alpha = 90^\circ$ and $V_{w_1} = 0$.

A centrifugal pump is the reverse of a radially inward flow reaction turbine. But in case of a radially inward flow reaction turbine, the work done by the water on the runner per second per unit weight of the water striking per second is given by equation (18.19) as

$$= \frac{1}{g} [V_{w_1} u_1 - V_{w_2} u_2]$$

\therefore Work done by the impeller on the water per second per unit weight of water striking per second

$$= - [\text{Work done in case of turbine}]$$

$$= - \left[\frac{1}{g} (V_{w_1} u_1 - V_{w_2} u_2) \right] = \frac{1}{g} [V_{w_2} u_2 - V_{w_1} u_1]$$

$$= \frac{1}{g} V_{w_2} u_2 \quad (\because V_{w_1} = 0 \text{ here})$$

Work done by impeller on water per second

$$= \frac{W}{g} \cdot V_{w_2} u_2$$

where $W = \text{Weight of water} = \rho \times g \times Q$

where $Q = \text{Volume of water}$

and

$$Q = \text{Area} \times \text{Velocity of flow} = \pi D_1 B_1 \times V_{f_1} \\ = \pi D_2 B_2 \times V_{f_2}$$

where B_1 and B_2 are width of impeller at inlet and outlet and V_{f_1} and V_{f_2} are velocities of flow at inlet and outlet.

DEFINITIONS OF HEADS AND EFFICIENCIES OF A CENTRIFUGAL PUMP

1. Suction Head (h_s). It is the vertical height of the centre line of the centrifugal pump above the water surface in the tank or pump from which water is to be lifted as shown in Fig. This height is also called suction lift and is denoted by ' h_s '.

2. Delivery Head (h_d). The vertical distance between the centre line of the pump and the water surface in the tank to which water is delivered is known as delivery head. This is denoted by ' h_d '.

3. Static Head (H_s). The sum of suction head and delivery head is known as static head. This is represented by ' H_s ' and is written as

$$H_s = h_s + h_d.$$

4. Manometric Head (H_m). The manometric head is defined as the head against which a centrifugal pump has to work. It is denoted by ' H_m '. It is given by the following expressions :

(a) $H_m =$ Head imparted by the impeller to the water – Loss of head in the pump

$$= \frac{V_{w_2} u_2}{g} - \text{Loss of head in impeller and casing}$$

$$= \frac{V_{w_2} u_2}{g} \text{ ...if loss of pump is zero}$$

(b) $H_m =$ Total head at outlet of the pump – Total head at the inlet of the pump

$$= \left(\frac{P_o}{\rho g} + \frac{V_o^2}{2g} + Z_o \right) - \left(\frac{P_i}{\rho g} + \frac{V_i^2}{2g} + Z_i \right)$$

where $\frac{P_o}{\rho g} =$ Pressure head at outlet of the pump $= h_d$

$\frac{V_o^2}{2g} =$ Velocity head at outlet of the pump

$=$ Velocity head in delivery pipe $= \frac{V_d^2}{2g}$

$Z_o =$ Vertical height of the outlet of the pump from datum line, and

$\frac{P_i}{\rho g}, \frac{V_i^2}{2g}, Z_i =$ Corresponding values of pressure head, velocity head and datum head at the inlet of the pump,

i.e., $h_s, \frac{V_s^2}{2g}$ and Z_s respectively.

$$(c) \quad H_m = h_s + h_d + h_{f_s} + h_{f_d} + \frac{V_d^2}{2g}$$

where h_s = Suction head, h_d = Delivery head,
 h_{f_s} = Frictional head loss in suction pipe, h_{f_d} = Frictional head loss in delivery pipe, and
 V_d = Velocity of water in delivery pipe.

EFFICIENCY OF CENTRIFUGAL PUMP

(a) **Manometric Efficiency (η_{man})**. The ratio of the manometric head to the head imparted by the impeller to the water is known as manometric efficiency. Mathematically, it is written as

$$\eta_{man} = \frac{\text{Manometric head}}{\text{Head imparted by impeller to water}}$$

The power at the impeller of the pump is more than the power given to the water at outlet of the pump. The ratio of the power given to water at outlet of the pump to the power available at the impeller, is known as manometric efficiency.

$$\text{The power given to water at outlet of the pump} = \frac{WH_m}{1000} \text{ kW}$$

$$\text{The power at the impeller} = \frac{\text{Work done by impeller per second}}{1000} \text{ kW}$$

$$= \frac{W}{g} \times \frac{V_{w_2} \times u_2}{1000} \text{ kW}$$

$$\eta_{man} = \frac{\frac{W \times H_m}{1000}}{\frac{W}{g} \times \frac{V_{w_2} \times u_2}{1000}} = \frac{g \times H_m}{V_{w_2} \times u_2}$$

(b) **Mechanical Efficiency (η_m)**. The power at the shaft of the centrifugal pump is more than the power available at the impeller of the pump. The ratio of the power available at the impeller to the power at the shaft of the centrifugal pump is known as mechanical efficiency. It is written as

$$\eta_m = \frac{\text{Power at the impeller}}{\text{Power at the shaft}}$$

$$\text{The power at the impeller in kW} = \frac{\text{Work done by impeller per second}}{1000}$$

$$= \frac{W}{g} \times \frac{V_{w_2} u_2}{1000}$$

$$\eta_m = \frac{\frac{W}{g} \left(\frac{V_{w_2} u_2}{1000} \right)}{\text{S.P.}}$$

(c) **Overall Efficiency (η_o)**. It is defined as ratio of power output of the pump to the power input to the pump. The power output of the pump in kW

$$= \frac{\text{Weight of water lifted} \times H_m}{1000} = \frac{WH_m}{1000}$$

Power input to the pump

= Power supplied by the electric motor

= S.P. of the pump.

\therefore

$$\eta_o = \frac{\left(\frac{WH_m}{1000} \right)}{\text{S.P.}}$$

Also

$$\eta_o = \eta_{man} \times \eta_m.$$

MULTISTAGE CENTRIFUGAL PUMPS

If a centrifugal pump consists of two or more impellers, the pump is called a multistage centrifugal pump. The impellers may be mounted on the same shaft or on different shafts. A multistage pump is having the following two important functions :

1. To produce a high head, and
2. To discharge a large quantity of liquid.

If a high head is to be developed, the impellers are connected in series (or on the same shaft) while for discharging large quantity of liquid, the impellers (or pumps) are connected in parallel.

Multistage Centrifugal Pumps for High Heads.

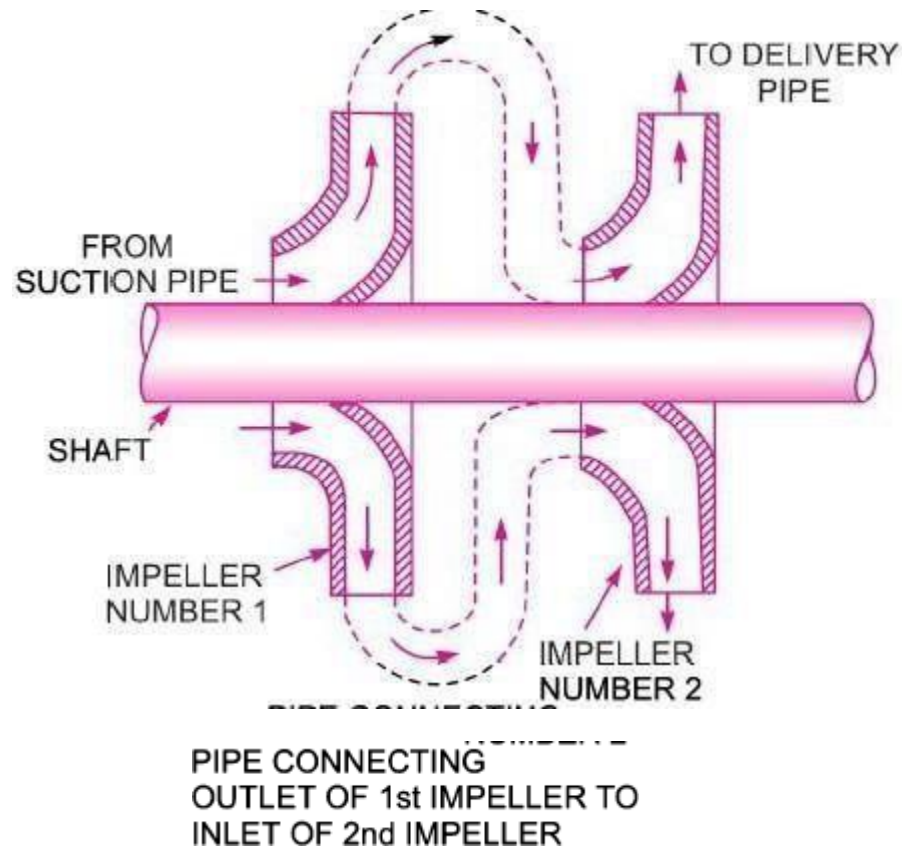

Two-stage pumps with impellers in series.

Let n = Number of identical impellers mounted on the same shaft,

H_m = Head developed by each impeller.

Then total head developed

$$= n \times H_m$$

The discharge passing through each impeller is same

Multistage Centrifugal Pumps for High Discharge.

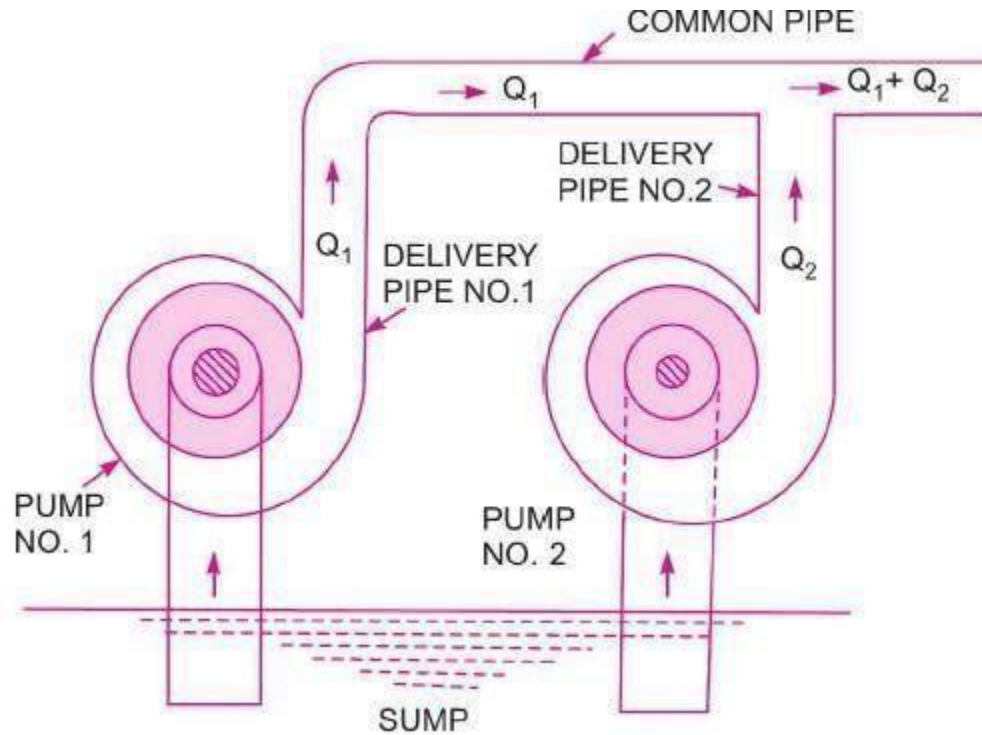

Fig. *Pumps in parallel.*

Let

n = Number of identical pumps arranged in parallel.

Q = Discharge from one pump.

\therefore Total discharge

$$= n \times Q$$

PRIMING OF A CENTRIFUGAL PUMP

Priming of a centrifugal pump is defined as the operation in which the suction pipe, casing of the pump and a portion of the delivery pipe upto the delivery valve is completely filled up from outside source with the liquid to be raised by the pump before starting the pump. Thus the air from these parts of the pump is removed and these parts are filled with the liquid to be pumped.

The work done by the impeller per unit weight of liquid per sec is known as the head generated by the pump. Equation
$$H = \frac{1}{g} V_{w_2} u_2$$
 gives the head generated by the pump as $= \frac{1}{g} V_{w_2} u_2$ metre. This equation is independent of the density of the liquid. This means that when pump is running in air, the head generated is in terms of metre of air. If the pump is primed with water, the head generated is same metre of water. But as the density of air is very low, the generated head of air in terms of equivalent metre of water head is negligible and hence the water may not be sucked from the pump. To avoid this difficulty, priming is necessary.

CAVITATION

Cavitation is defined as the phenomenon of formation of vapour bubbles of a flowing liquid in a region where the pressure of the liquid falls below its vapour pressure and the sudden collapsing of these vapour bubbles in a region of higher pressure. When the vapour bubbles collapse, a very high pressure is created. The metallic surfaces, above which these vapour bubbles collapse, is subjected to these high pressures, which cause pitting action on the surface. Thus cavities are formed on the metallic surface and also considerable noise and vibrations are produced.

Cavitation includes formation of vapour bubbles of the flowing liquid and collapsing of the vapour bubbles. Formation of vapour bubbles of the flowing liquid take place only whenever the pressure in any region falls below vapour pressure. When the pressure of the flowing liquid is less than its vapour pressure, the liquid starts boiling and vapour bubbles are formed. These vapour bubbles are carried along with the flowing liquid to higher pressure zones where these vapours condense and bubbles collapse. Due to sudden collapsing of the bubbles on the metallic surface, high pressure is produced and metallic surfaces are subjected to high local stresses. Thus the surfaces are damaged.

Precaution Against Cavitation.

(i) The pressure of the flowing liquid in any part of the hydraulic system should not be allowed to fall below its vapour pressure. If the flowing liquid is water, then the absolute pressure head should not be below 2.5 m of water.

(ii) The special materials or coatings such as aluminium-bronze and stainless steel, which are cavitation resistant materials, should be used.

Effects of Cavitation.

(i) The metallic surfaces are damaged and cavities are formed on the surfaces.

(ii) Due to sudden collapse of vapour bubble, considerable noise and vibrations are produced.

(iii) The efficiency of a turbine decreases due to cavitation. Due to pitting action, the surface of the turbine blades becomes rough and the force exerted by water on the turbine blades decreases. Hence, the work done by water or output horse power becomes less and thus efficiency decreases.

Hydraulic Machines Subjected to Cavitation.

Cavitation in Turbines. In turbines, only reaction turbines are subjected to cavitation. In reaction turbines the cavitation may occur at the outlet of the runner or at the inlet of the draft-tube where the pressure is considerably reduced (*i.e.*, which may be below the vapour pressure of the liquid flowing through the turbine). Due to cavitation, the metal of the runner vanes and draft-tube is gradually eaten away, which results in lowering the efficiency of the turbine. Hence, the cavitation in a reaction turbine can be noted by a sudden drop in efficiency. In order to determine whether cavitation will occur in any portion of a reaction turbine, the critical value of Thoma's cavitation factor (σ , sigma) is calculated.

Thoma's Cavitation Factor for Reaction Turbines. Prof. D. Thoma suggested a dimensionless number, called after his name Thoma's cavitation factor σ (sigma), which can be used for determining the region where cavitation takes place in reaction turbines. The mathematical expression for the Thoma's cavitation factor is given by

$$\sigma = \frac{H_b - H_s}{H} = \frac{(H_{atm} - H_v) - H_s}{H} \quad \dots(19.23)$$

where H_b = Barometric pressure head in m of water,
 H_{atm} = Atmospheric pressure head in m of water,
 H_v = Vapour pressure head in m of water,
 H_s = Suction pressure at the outlet of reaction turbine in m of water or height of turbine runner above the tail water surface,
 H = Net head on the turbine in m.

Cavitation in Centrifugal Pumps.

Cavitation in Centrifugal Pumps. In centrifugal pumps the cavitation may occur at the inlet of the impeller of the pump, or at the suction side of the pumps, where the pressure is considerably reduced. Hence if the pressure at the suction side of the pump drops below the vapour pressure of the liquid then the cavitation may occur. The cavitation in a pump can be noted by a sudden drop in efficiency and head. In order to determine whether cavitation will occur in any portion of the suction side of the pump, the critical value of Thoma's cavitation factor (σ) is calculated.

Thoma's Cavitation Factor for Centrifugal Pumps. The mathematical expression for Thoma's cavitation factor for centrifugal pump is given by

$$\sigma = \frac{(H_b) - H_S - h_{LS}}{H} = \frac{(H_{atm} - H_V) - H_S - h_{LS}}{H}$$

where H_{atm} = Atmospheric pressure head in m of water or absolute pressure head at the liquid surface in pump,

H_V = Vapour pressure head in m of water,

H_S = Suction pressure head in m of water,

h_{LS} = Head lost due to friction in suction pipe, and

H = Head developed by the pump.

RECIPROCATING PUMP

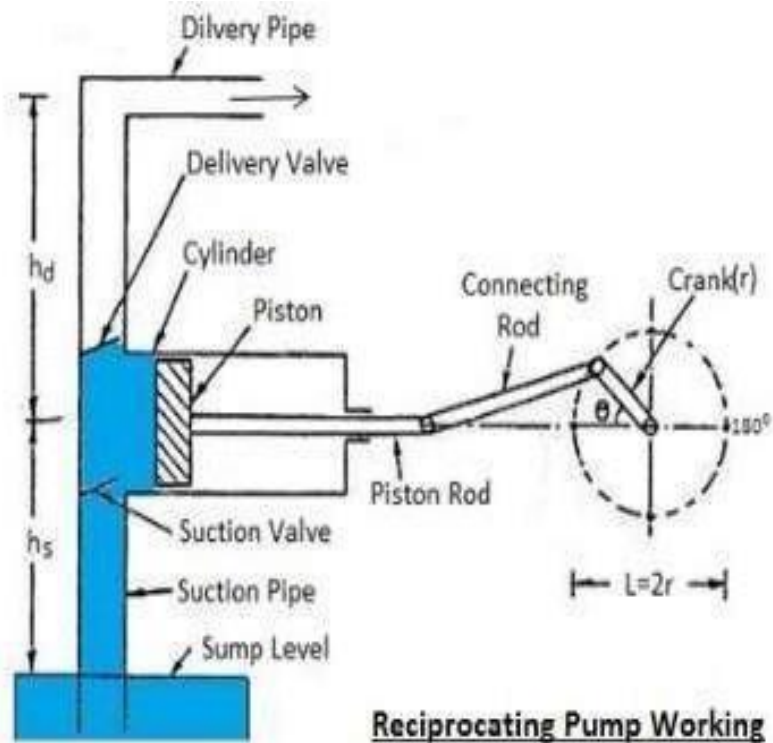

Reciprocating Pump Working

Reciprocating Pump Working

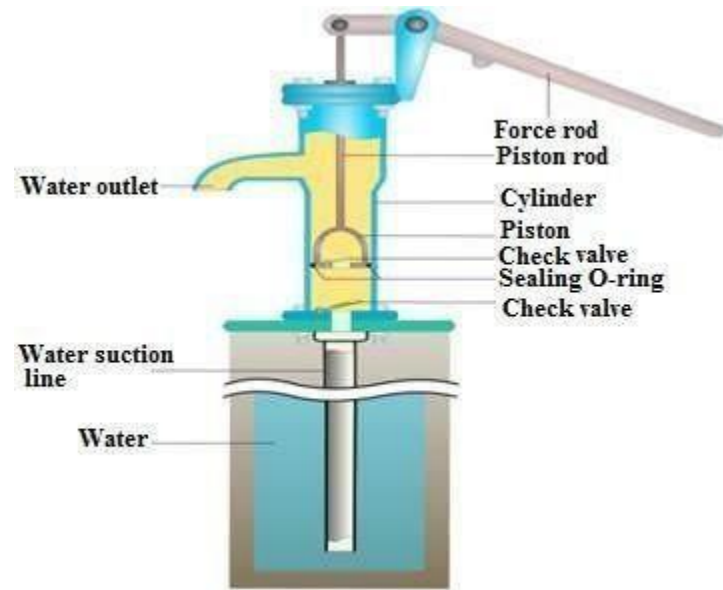

INTRODUCTION

In the last chapter, we have defined the pumps as the hydraulic machines which convert the mechanical energy into hydraulic energy which is mainly in the form of pressure energy. If the mechanical energy is converted into hydraulic energy, by means of centrifugal force acting on the liquid, the pump is known as centrifugal pump. But if the mechanical energy is converted into hydraulic energy (or pressure energy) by sucking the liquid into a cylinder in which a piston is reciprocating (moving backwards and forwards), which exerts the thrust on the liquid and increases its hydraulic energy (pressure energy), the pump is known as reciprocating pump.

MAIN PARTS OF RECIPROCATING PUMP

1. A cylinder with a piston, piston rod, connecting rod and a crank,
2. Suction pipe,
3. Delivery pipe,
4. Suction valve, and
5. Delivery valve.

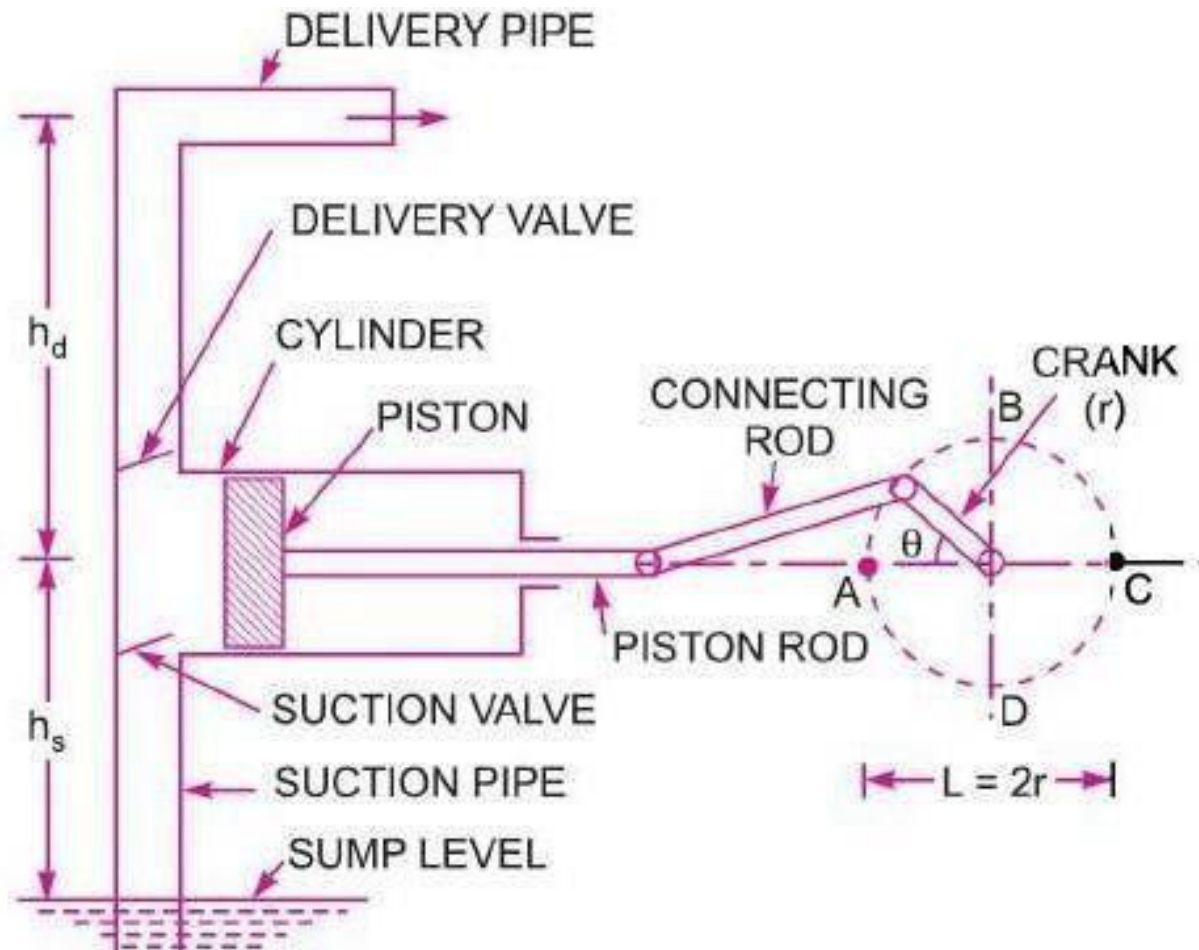

WORKING OF SINGLE ACTING RECIPROCATING PUMP

Fig. 1 shows a single acting reciprocating pump, which consists of a piston which moves forwards and backwards in a close fitting cylinder. The movement of the piston is obtained by connecting the piston rod to crank by means of a connecting rod. The crank is rotated by means of an electric motor. Suction and delivery pipes with suction valve and delivery valve are connected to the cylinder. The suction and delivery valves are one way valves or non-return valves, which allow the water to flow in one direction only. Suction valve allows water from suction pipe to the cylinder which delivery valve allows water from cylinder to delivery pipe only.

When crank starts rotating, the piston moves to and fro in the cylinder. When crank is at A , the piston is at the extreme left position in the cylinder. As the crank is rotating from A to C , (*i.e.*, from $\theta = 0^\circ$ to $\theta = 180^\circ$), the piston is moving towards right in the cylinder. The movement of the piston towards right creates a partial vacuum in the cylinder. But on the surface of the liquid in the sump atmospheric pressure is acting, which is more than the pressure inside the cylinder. Thus, the liquid is forced in the suction pipe from the sump. This liquid opens the suction valve and enters the cylinder.

When crank is rotating from C to A (*i.e.*, from $\theta = 180^\circ$ to $\theta = 360^\circ$), the piston from its extreme right position starts moving towards left in the cylinder. The movement of the piston towards left increases the pressure of the liquid inside the cylinder more than atmospheric pressure. Hence suction valve closes and delivery valve opens. The liquid is forced into the delivery pipe and is raised to a required height.

Discharge Through a Reciprocating Pump. Consider a single* acting reciprocating pump as shown in Fig.

Let D = Diameter of the cylinder

A = Cross-sectional area of the piston or cylinder

$$= \frac{\pi}{4} D^2$$

r = Radius of crank

N = r.p.m. of the crank

L = Length of the stroke = $2 \times r$

h_s = Height of the axis of the cylinder from water surface in sump.

h_d = Height of delivery outlet above the cylinder axis (also called delivery head)

Volume of water delivered in one revolution or discharge of water in one revolution

$$= \text{Area} \times \text{Length of stroke} = A \times L$$

Number of revolution per second, = $\frac{N}{60}$

\therefore Discharge of the pump per second,

Q = Discharge in one revolution \times No. of revolution per second

$$= A \times L \times \frac{N}{60} = \frac{ALN}{60}$$

Weight of water delivered per second,

$$W = \rho \times g \times Q = \frac{\rho g ALN}{60}$$

Work done by Reciprocating Pump. Work done by the reciprocating pump per second is given by the reaction as

$$\begin{aligned}\text{Work done per second} &= \text{Weight of water lifted per second} \times \text{Total height through which water is lifted} \\ &= W \times (h_s + h_d) \quad \dots(i)\end{aligned}$$

where $(h_s + h_d)$ = Total height through which water is lifted.

From equation Weight, W , is given by

$$W = \frac{\rho g \times ALN}{60}$$

Substituting the value of W in equation (i), we get

$$\text{Work done per second} = \frac{\rho g \times ALN}{60} \times (h_s + h_d)$$

\therefore Power required to drive the pump, in kW

$$\begin{aligned}P &= \frac{\text{Work done per second}}{1000} = \frac{\rho g \times ALN \times (h_s + h_d)}{60 \times 1000} \\ &= \frac{\rho g \times ALN \times (h_s + h_d)}{60,000} \text{ kW}\end{aligned}$$

DOUBLEACTINGRECIPROCATINGPUMP

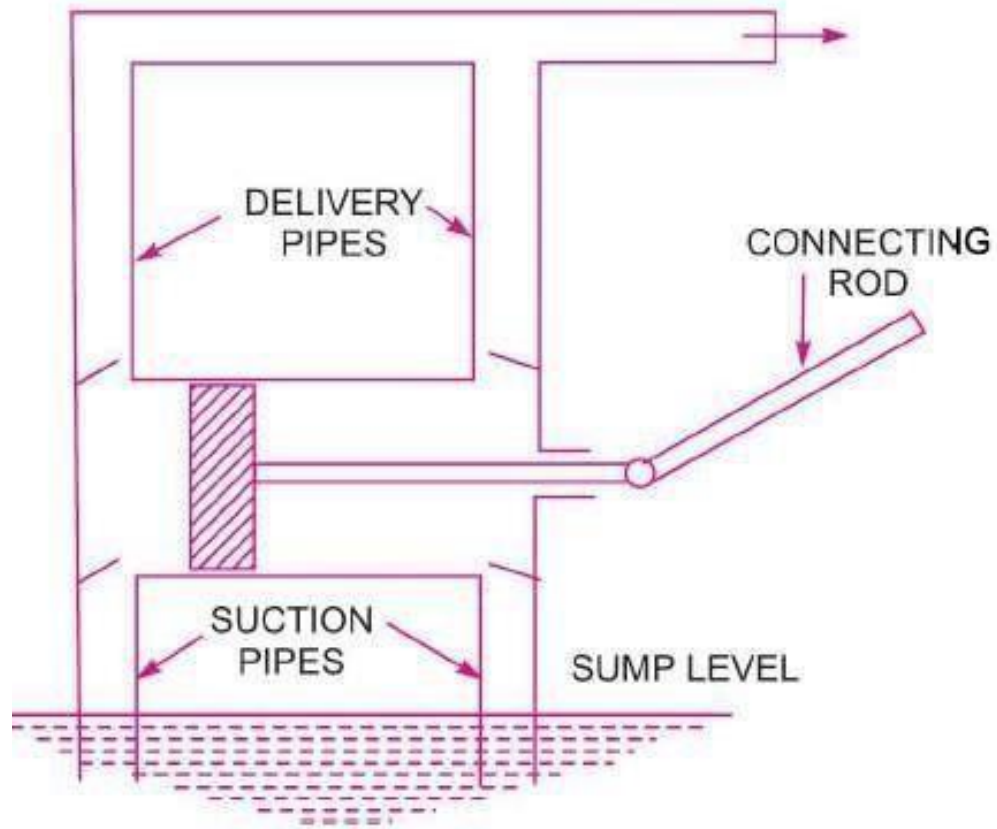

Discharge, Work done and Power Required to Drive a Double-acting Pump.

In case of double-acting pump, the water is acting on both sides of the piston as shown in Fig.

Thus, we require two suction pipes and two delivery pipes for double-acting pump. When there is a suction stroke on one side of the piston, there is at the same time a delivery stroke on the other side of the piston. Thus for one complete revolution of the crank there are two delivery strokes and water is delivered to the pipes by the pump during these two delivery strokes.

Let D = Diameter of the piston,

d = Diameter of the piston rod

∴ Area on one side of the piston, —

$$A = \frac{\pi}{4} D^2$$

Area on the other side of the piston, where piston rod is connected to the piston,

$$A_1 = \frac{\pi}{4} D^2 - \frac{\pi}{4} d^2 = \frac{\pi}{4} (D^2 - d^2).$$

∴ Volume of water delivered in one revolution of crank

$$= A \times \text{Length of stroke} + A_1 \times \text{Length of stroke}$$

$$= AL + A_1L = (A + A_1)L = \left[\frac{\pi}{4} D^2 + \frac{\pi}{4} (D^2 - d^2) \right] \times L$$

∴ Discharge of pump per second

$$= \text{Volume of water delivered in one revolution} \times \text{No. of revolution per second}$$

$$= \left[\frac{\pi}{4} D^2 + \frac{\pi}{4} (D^2 - d^2) \right] \times L \times \frac{N}{60}$$

If 'd' the diameter of the piston rod is very small as compared to the diameter of the piston, then it can be neglected and discharge of pump per second,

$$Q = \left(\frac{\pi}{4} D^2 + \frac{\pi}{4} D^2 \right) \times \frac{L \times N}{60} = 2 \times \frac{\pi}{4} D^2 \times \frac{L \times N}{60} = \frac{2ALN}{60} \dots$$

Equation gives the discharge of a double-acting reciprocating pump. This discharge is two times the discharge of a single-acting pump.

Work done by double-acting reciprocating pump

Work done per second = Weight of water delivered \times Total height

$$= \rho g \times \text{Discharge per second} \times \text{Total height}$$

$$= \rho g \times \frac{2ALN}{60} \times (h_s + h_d) = 2\rho g \times \frac{ALN}{60} \times (h_s + h_d)$$

\therefore Power required to drive the double-acting pump in kW,

$$P = \frac{\text{Work done per second}}{1000} = 2\rho g \times \frac{ALN}{60} \times \frac{(h_s + h_d)}{1000}$$
$$= \frac{2\rho g \times ALN \times (h_s + h_d)}{60,000}$$

Slip of Reciprocating Pump

Slip of a pump is defined as the difference between the theoretical discharge and actual discharge of the pump. The discharge of a single-acting pump given by equation (20.1) and of a double-acting pump given by equation (20.5) are theoretical discharge. The actual discharge of a pump is less than the theoretical discharge due to leakage. The difference of the theoretical discharge and actual discharge is known as slip of the pump. Hence, mathematically,

$$\text{Slip} = Q_{th} - Q_{act}$$

But slip is mostly expressed as percentage slip which is given by,

$$\text{Percentage slip} = \frac{Q_{th} - Q_{act}}{Q_{th}} \times 100 = \left(1 - \frac{Q_{act}}{Q_{th}} \right) \times 100$$

$$= (1 - C_d) \times 100 \quad \left(\because \frac{Q_{act}}{Q_{th}} = C_d \right)$$

where C_d = Co-efficient of discharge.

Negative Slip of the Reciprocating Pump. Slip is equal to the difference of theoretical discharge and actual discharge. If actual discharge is more than the theoretical discharge, the slip of the pump will become -ve. In that case, the slip of the pump is known as negative slip.

Negative slip occurs when delivery pipe is short, suction pipe is long and pump is running at high speed.

Difference between Centrifugal pump and Reciprocating pump

Centrifugal pump is a rotodynamic pump that uses kinetic energy to transfer fluid from low pressure to high pressure while the reciprocating pump uses a piston (suction and discharge stroke) to transfer fluid. Centrifugal pump is the most popular pump as compared to the reciprocating pump. There are many differences between the Centrifugal pump and the reciprocating pump.

1. **Centrifugal pump is a rotary pump that uses the kinetic energy of the impeller to transfer liquid.**
A reciprocating pump is a positive displacement type pump which is forced through the piston.
2. **Centrifugal pump provides a steady flow (continuous discharge).**
The reciprocating pump provides pulsating flow.
3. **Centrifugal pump uses uniform torque.**
Reciprocating pump torque is not uniform.
4. **Centrifugal pump discharge is inversely proportional to the viscosity of working fluid.** In
Reciprocating pump viscosity of working fluid does not affect the pump discharge rate.

PneumaticSystem

S

- Pneumatic technology deals with the study of behaviour and applications of compressed air in our daily life in general and manufacturing automation in particular. Pneumatic systems use air as the medium which is abundantly available and can be exhausted into the atmosphere after completion of the assigned task.
- A pneumatic system is a system that uses compressed air to transmit and control energy.
- Pneumatic systems are used in controlling train doors, automatic production lines, mechanical clamps, etc (Fig. 1).

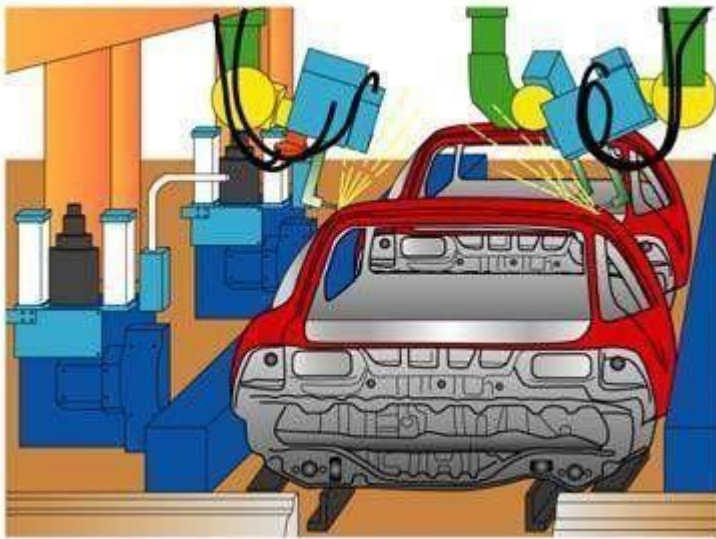

(a) Automobile production lines



(b) Pneumatic system of an automatic machine

Fig. 1 Common pneumatic systems used in the industrial sector

1. Basic Components of Pneumatic System

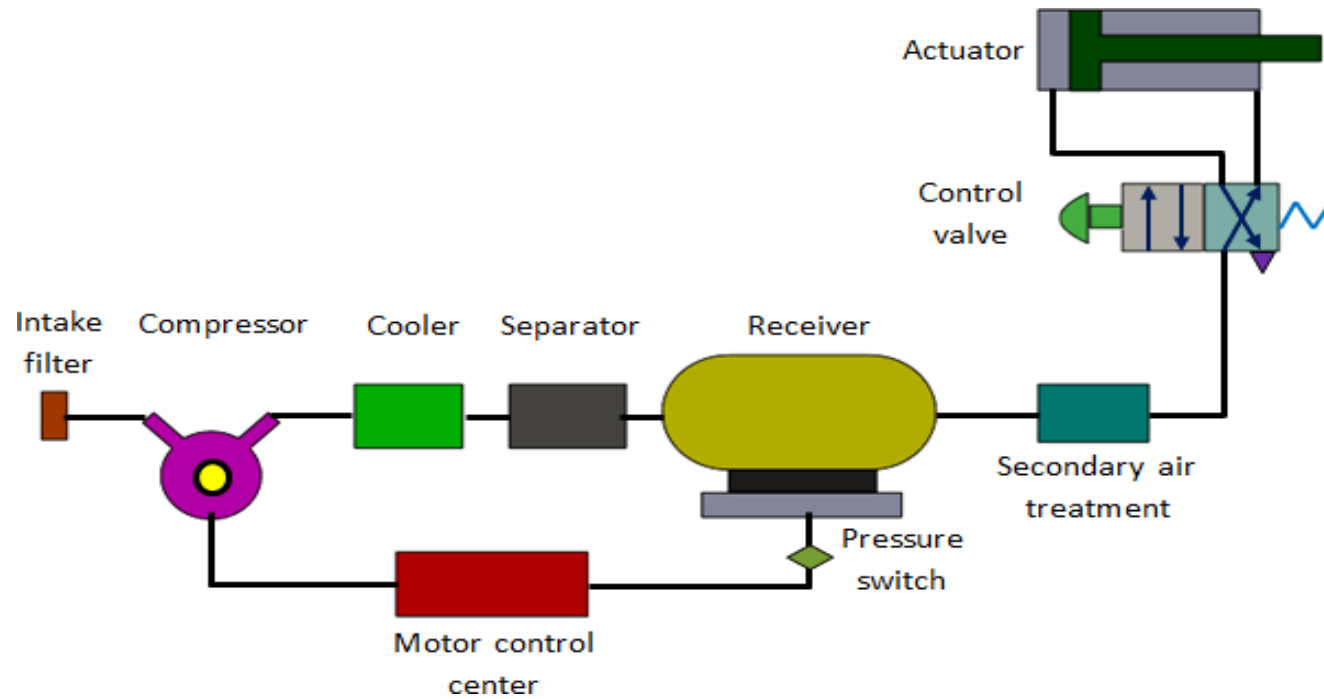

Fig2: Basic Components of Pneumatic System

a) Airfilters: These are used to filter out the contaminants from the air.

b) Compressor: Compressed air is generated by using air compressors. Air compressors are either diesel or electrically operated. Based on the requirement of compressed air, suitable capacity compressors may be used.

c) Aircooler: During compression operation, air temperature increases. Therefore coolers are used to reduce the temperature of the compressed air.

d) Dryer: The water vapour or moisture in the air is separated from the air by using a dryer.

e) Control Valves: Control valves are used to regulate, control and monitor for control of direction flow, pressure etc.

f) Air Actuator: Air cylinders and motors are used to obtain the required movements of mechanical elements of pneumatic system.

g) Electric Motor: Transform electrical energy into mechanical energy. It is used to drive the compressor.

h) Receiver tank: The compressed air coming from the compressor is stored in the air receiver.

2. Receivertank

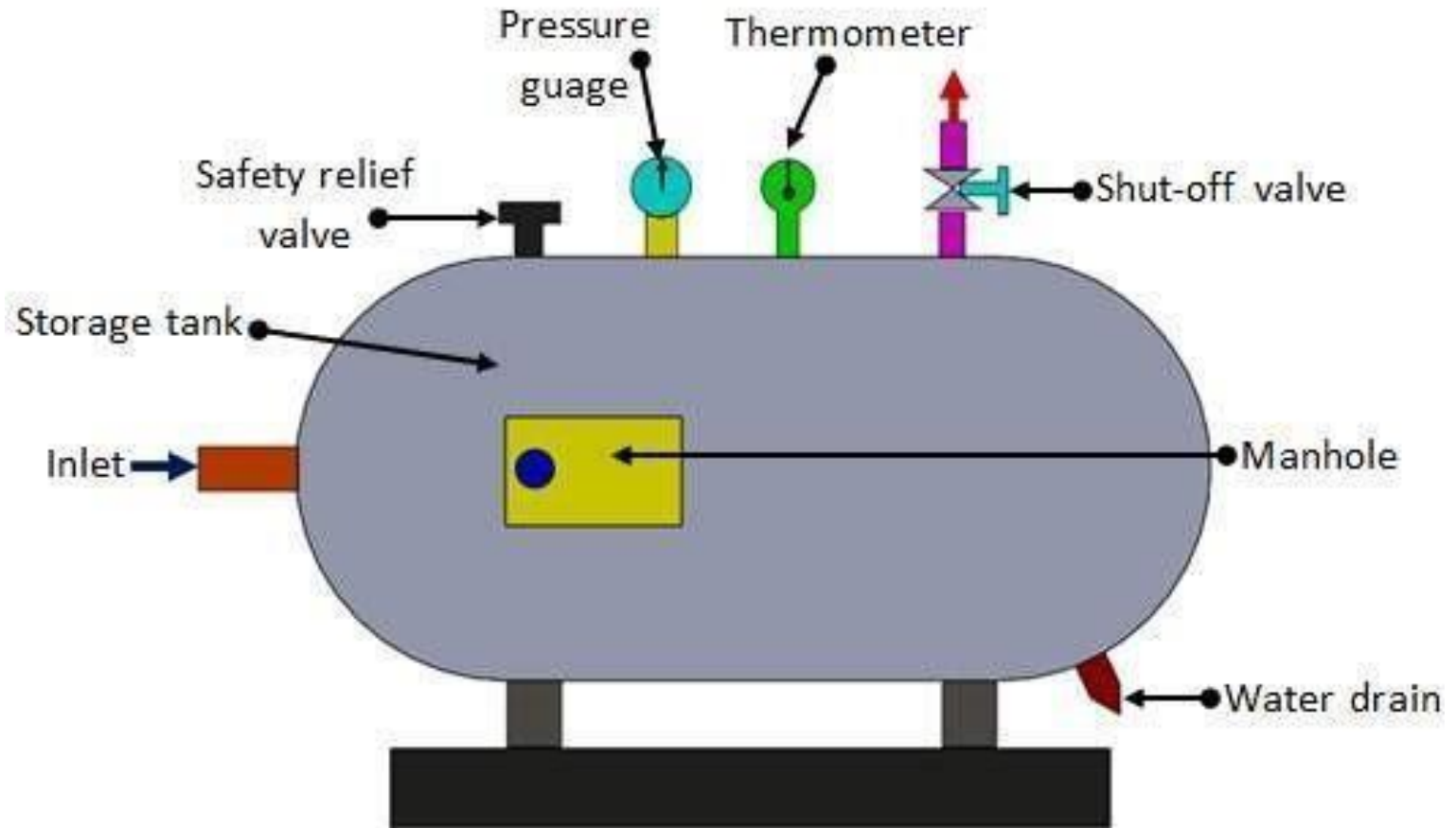

Fig3.Receivertank

The air is compressed slowly in the compressor. But since the pneumatic system needs continuous supply of air, this compressed air has to be stored. The compressed air is stored in an air receiver as shown in Figure 3. It also helps the air to cool and condense the moisture present. The air receiver should be large enough to hold all the air delivered by the compressor. The pressure in the receiver is held higher than the system operating pressure to compensate pressure loss in the pipes. Also the large surface area of the receiver helps in dissipating the heat from the compressed air. Generally the size of receiver depends on,

- Delivery volume of compressor.
- Air consumption.
- Pipeline network
- Type and nature of on-off regulation
- Permissible pressure difference in the pipelines

Main pneumatic components

Pneumatic components can be divided into two categories:

1. Components that produce and transport compressed air.
2. Components that consume compressed air.

1. The production and transportation of compressed air

Examples of components that produce and transport compressed air include compressors and pressure regulating components.

(a) Compressor

It is a mechanical device which converts mechanical energy into fluid energy. The compressor increases the air pressure by reducing its volume which also increases the temperature of the compressed air. The compressor is selected based on the pressure it needs to operate and the delivery volume.

The compressor can be classified into two main types

- a. Positive displacement compressors and
- b. Dynamic displacement compressor

Positive displacement compressors include piston type, vane type, diaphragm type and screw type.



Fig4(a) Compressor used in schools



(b) Compressor used in laboratories

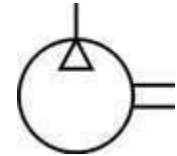

(c) Pneumatic symbol of compressor

Piston compressors

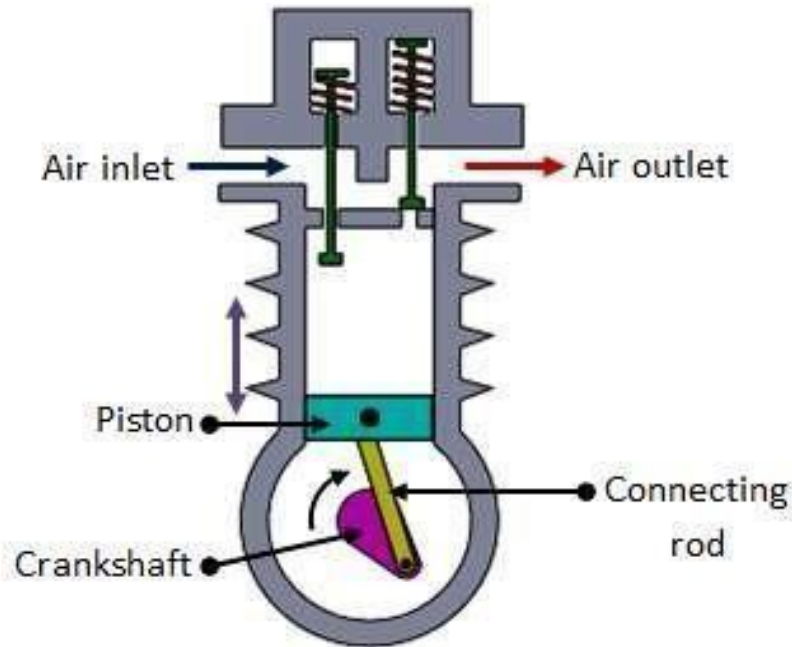

Fig5pistoncompressor

Piston compressors are commonly used in pneumatic systems. The simplest form is single cylinder compressor (Fig.5). It produces one pulse of air per piston stroke. As the piston moves down during the inlet stroke the inlet valve opens and air is drawn into the cylinder. As the piston moves up the inlet valve closes and the exhaust valve opens which allows the air to be expelled. The valves are spring loaded. The single cylinder compressor gives significant amount of pressure pulses at the outlet port. The pressure developed is about 3-40 bar.

Doubleacting compressor

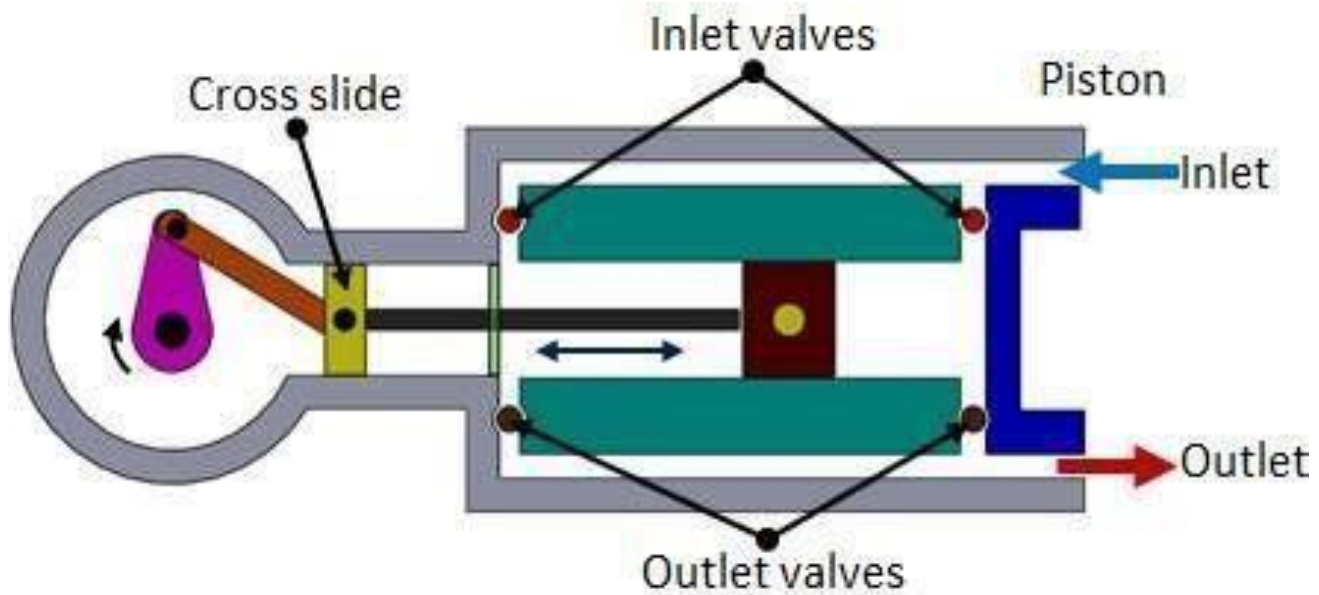

Fig6doubleactingpistoncompressor

The pulsation of air can be reduced by using double acting compressor as shown in Figure 6 It has two sets of valves and a crosshead. As the piston moves, the air is compressed on one side whilst on the other side of the piston, the air is sucked in. Due to the reciprocating action of the piston, the air is compressed and delivered twice in one piston stroke. Pressure higher than 30bar can be produced.

Multistagecompressor

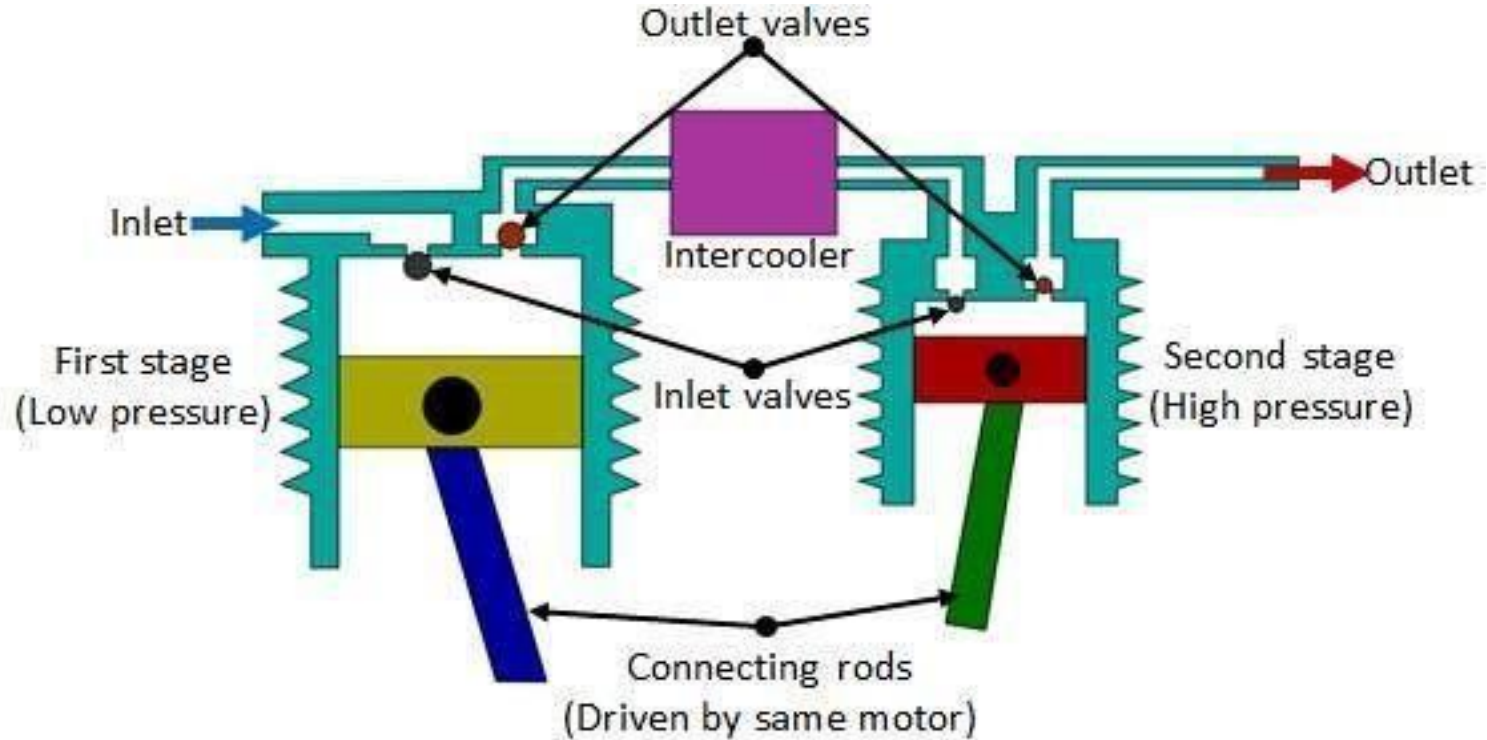

Fig7multistagecompressor

As the pressure of the air increases, its temperature rises. It is essential to reduce the air temperature to avoid damage of compressor and other mechanical elements. The multistage compressor with intercooler in-between is shown in Figure 7. It is used to reduce the temperature of compressed air during the compression stages. The intercooling reduces the volume of air which used to increase due to heat. The compressed air from the first stage enters the intercooler where it is cooled. This air is given as input to the second stage where it is compressed again. The multistage compressor can develop a pressure of around 50bar.

Rotaryvanecompressors

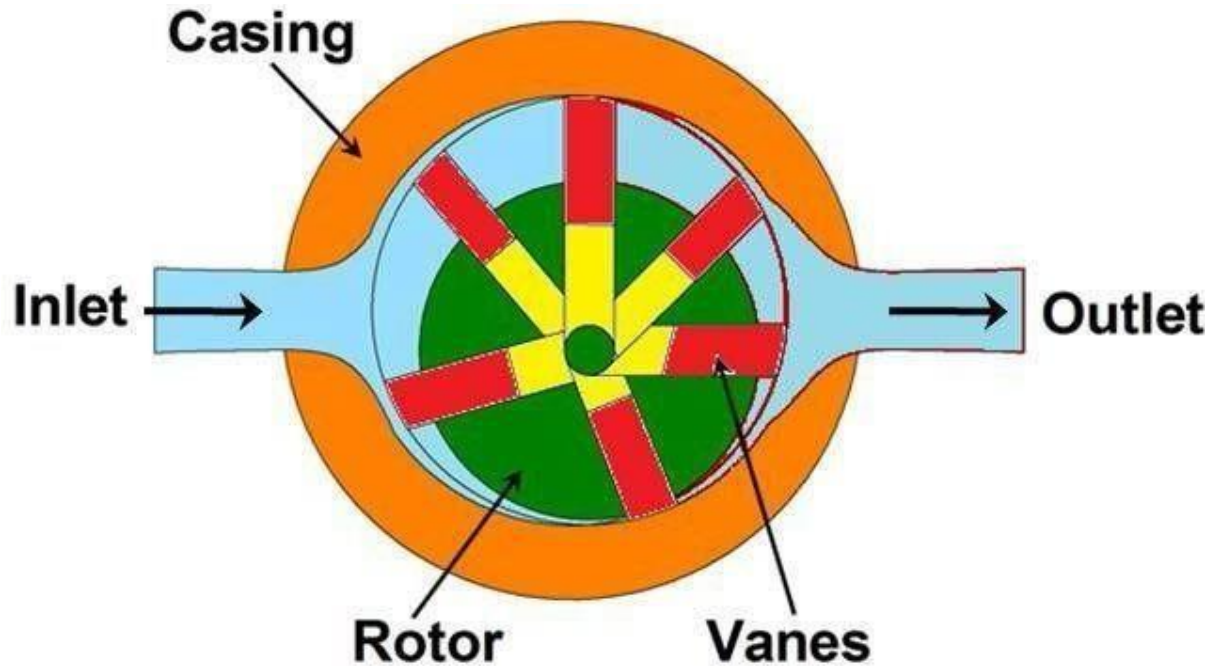

Fig8vanecompressor

The principle of operation of vane compressor is similar to the hydraulic vane pump. Figure 8 shows the working principle of Rotary vane compressor. The unbalanced vane compressor consists of spring loaded vanes seating in the slots of the rotor. The pumping action occurs due to movement of the vanes along a cam ring. The rotor is eccentric to the cam ring. As the rotor rotates, the vanes follow the inner surface of the cam ring. The space between the vanes decreases near the outlet due to the eccentricity. This causes compression of the air. These compressors are free from pulsation. If the eccentricity is zero no flow takes place

Lobecompressor

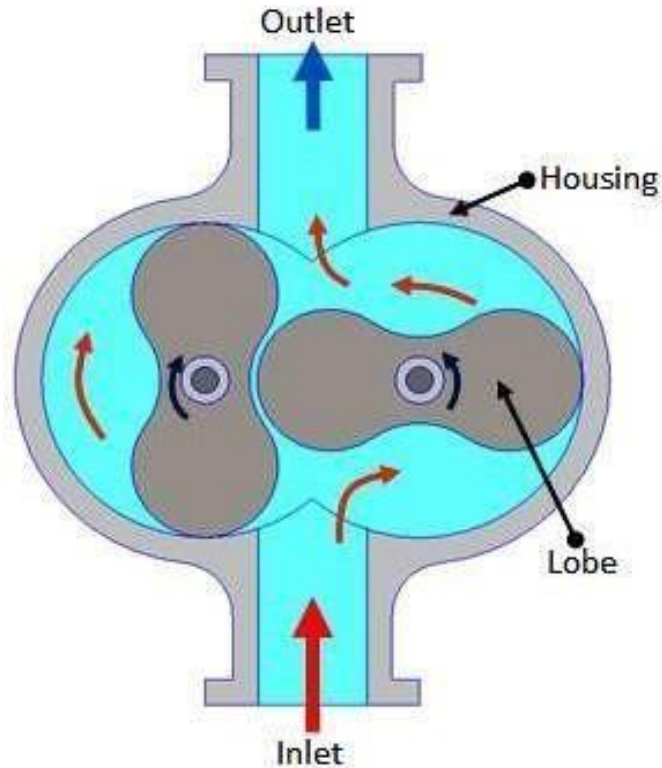

Fig9lobecompressor

The lobe compressor is used when high delivery volume but low pressure is needed. It consists of two lobes with one being driven and the other driving. Figure 9 shows the construction and working of Lobe compressor. It is similar to the Lobe pump used in hydraulic systems. The operating pressure is limited by leakage between rotors and housing. As the wear increases during the operation, the efficiency falls rapidly.

5. Dynamic compressors

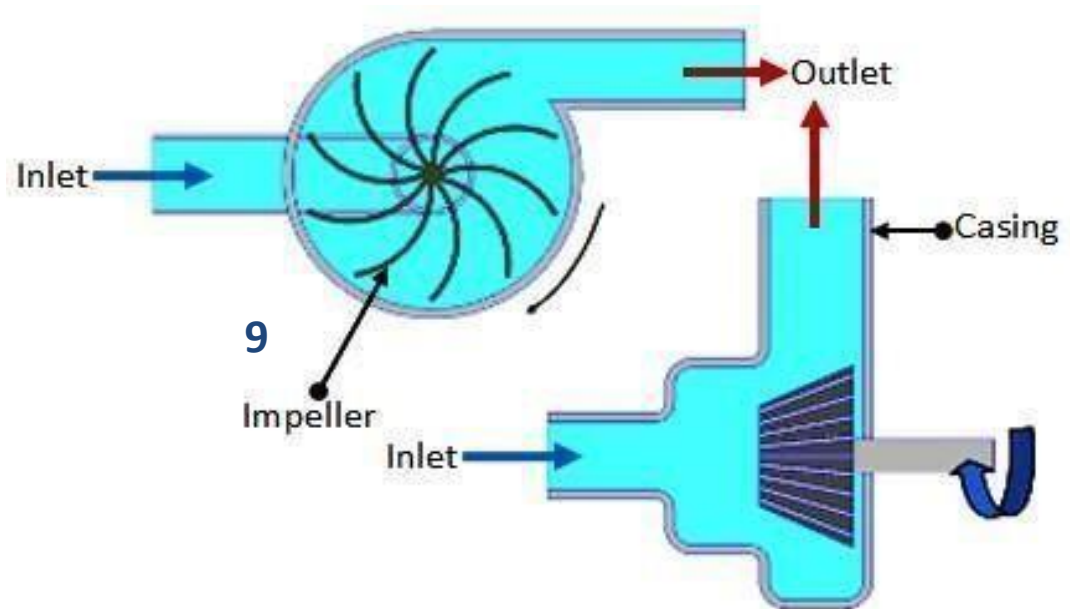

Fig10lobecompressor

Blower(Centrifugal type)

When very **large volume** of compressed air is required in applications such as ventilators, combustion system and pneumatic powder blower conveyors, the dynamic compressor can be used. The pressure needed is very low in such applications. Figure 10. shows a typical Centrifugal type blower. The impeller rotates at a high speed. Large volume of low pressure air can be provided by blowers. The blowers draw the air in and the impeller flings it out due to centrifugal force.

Air Treatment

And

**Pressure
Regulation**

1. Airtreatmentstages

For satisfactory operation of the pneumatic system the compressed air needs to be cleaned and dried. Atmospheric air is contaminated with dust, smoke and is humid. These particles can cause wear of the system components and presence of moisture may cause corrosion. Hence it is essential to treat the air to get rid of these impurities. The air treatment can be divided into three stages as shown in Figure .11

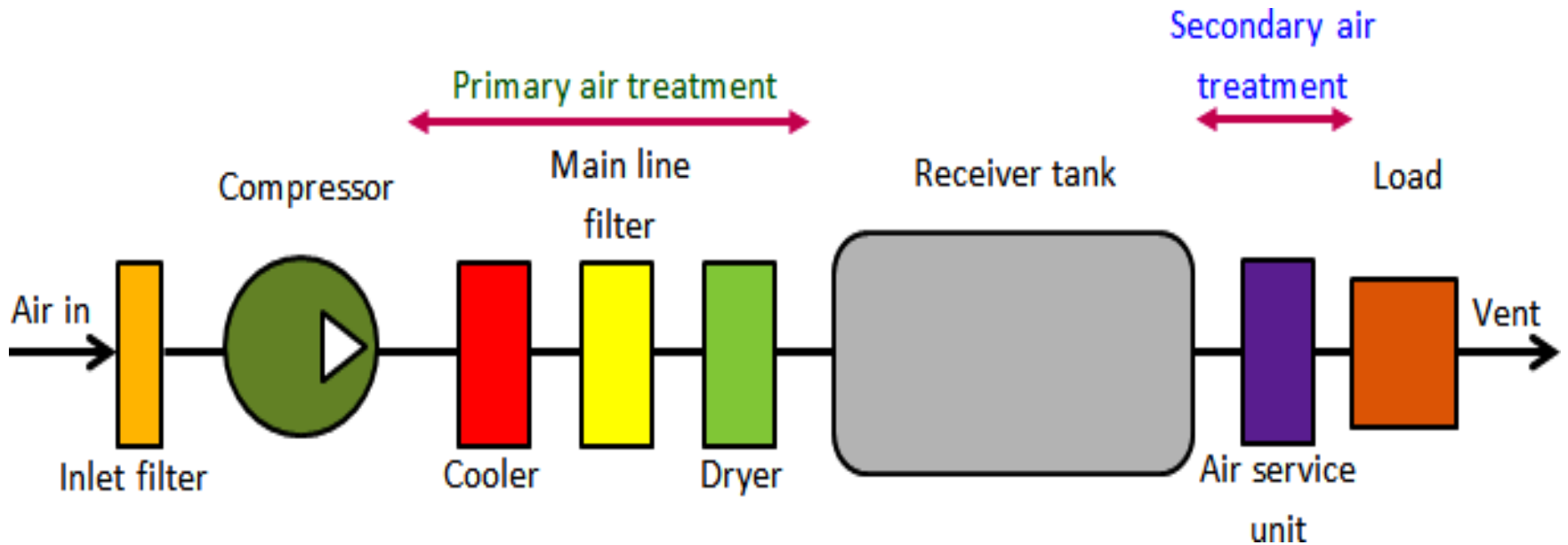

Figure.11

- In the first stage, the large sized particles are prevented from entering the compressor by an intake filter. The air leaving the compressor may be humid and may be at high temperature.
- The air from the compressor is treated in the second stage. In this stage temperature of the compressed air is lowered using a cooler and the air is dried using a dryer. Also an inline filter is provided to remove any contaminant particles present. This treatment is called **primary air treatment**.
- In the third stage which is the **secondary air treatment** process, further filtering is carried out. A lubricator introduces a fine mist of oil into the compressed air. This will help in lubrication of the moving components of the system to which the compressed air will be applied.

Filters

To prevent any damage to the compressor, the contaminants present in the air need to be filtered out. This is done by using inlet filters. These can be dry or wet filters. **Dry filters** use disposable cartridges. In the wet filter, the incoming air is passed through **an oil bath** and then through a **fine wire mesh** filter. Dirt particles cling to the oil drops during bubbling and are removed by wire mesh as they pass through it. In the dry filter the cartridges are replaced during servicing. The wet filters are cleaned using detergent solution.

Cooler

As the air is compressed, the temperature of the air increases. Therefore the air needs to be cooled. This is done by using a cooler. It is a type of heat exchanger. There are two types of coolers commonly employed viz. air cooled and water cooled. In the air cooled type, ambient air is used to cool the high temperature compressed air, whereas in the water cooled type, water is used as cooling medium. These are counter flow type coolers where the cooling medium flows in the direction opposite to the compressed air. During cooling, the water vapour present will condense which can be drained away later.

2. Mainlinefilter

These filters are used to remove the water vapors or solid contaminants present in the pneumatic systems main lines. These filters are discussed in detail as follows.

Air filter and water trap

Air filter and water trap is used to

- prevent any solid contaminants from entering in the system.
- condense and remove water vapour that is present in the compressed air.

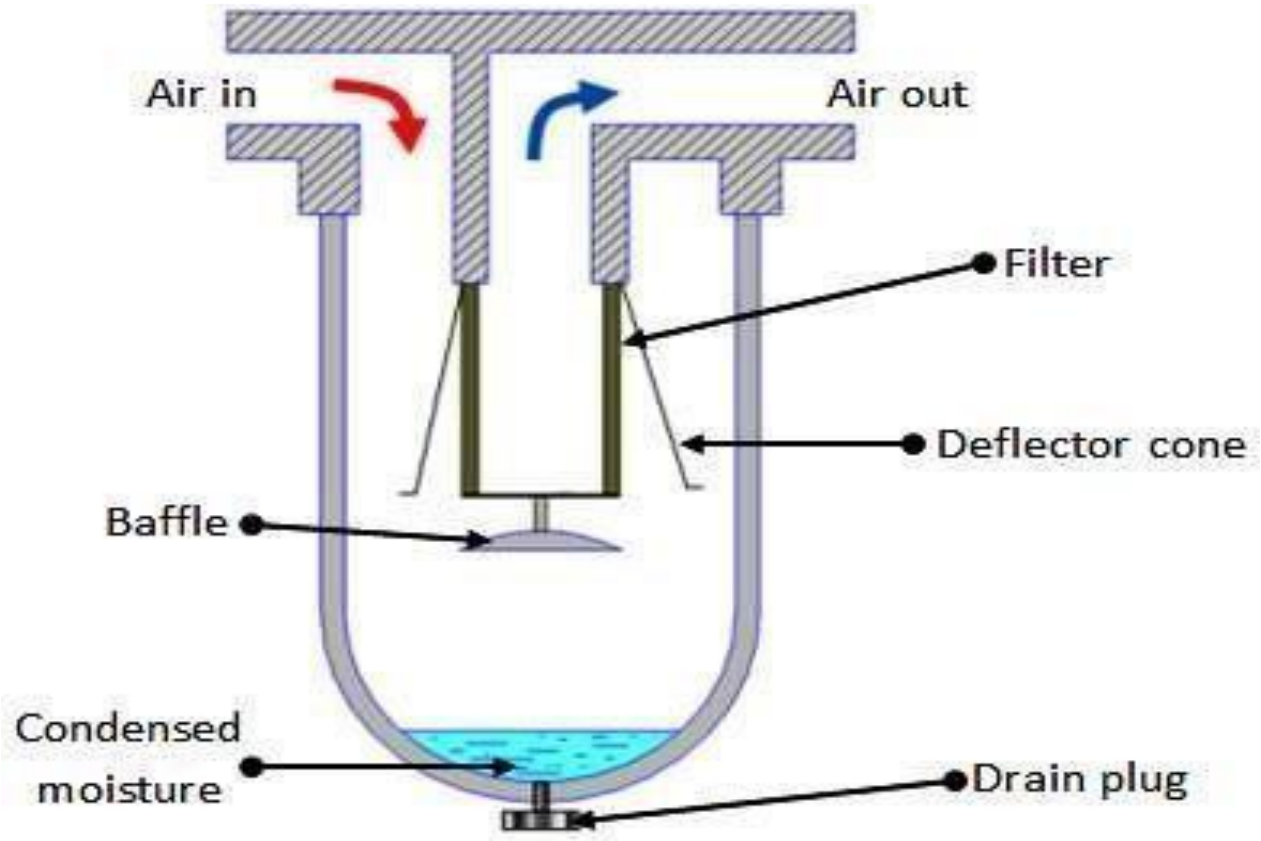

Fig12 Air filter and water trap

The filter cartridge is made of sintered brass. The schematic of the filter is shown in Fig. 12 . The thickness of sintered cartridge provides random zigzag passage for the air to flow-in which helps in arresting the solid particles. The air entering the filter swirls around due to the deflector cone. The centrifugal action causes the large contaminants and water vapour to be flung out, which hit the glass bowl and get collected at the bottom. A baffle plate is provided to prevent the turbulent air from splashing the water into the filter cartridge. At the bottom of the filter bowl there is a drain plug which can be opened manually to drain off the settled water and solid particles.

Refrigerated dryers

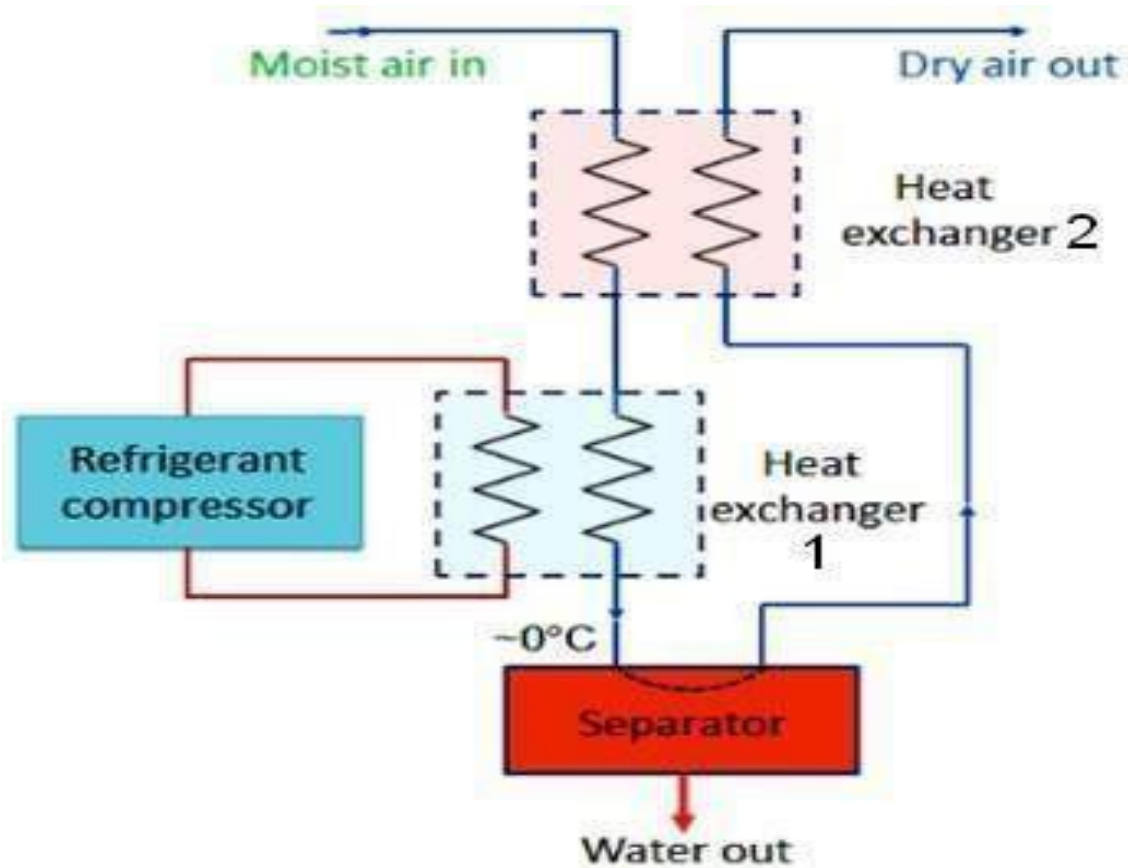

Fig13refrigerateddryer

It consists of two heat exchangers, refrigerant compressor and a separator. The system circuitry is shown in Figure 12. The dryer chills the air just above 0 °C which condenses the water vapour.

The condensate is collected by the separator. However such low temperature air may not be needed at the application. Therefore this chilled air is used to cool the high temperature air coming out from the compressor at heat exchanger 2.

The moderate temperature dry air coming out from the heat exchanger 2 is then used for actual application; whilst the reduced temperature air from compressor will further be cooled at heat exchanger 1. Thus, the efficiency of the system is increased by employing a second heat exchanger.

3. Lubricators

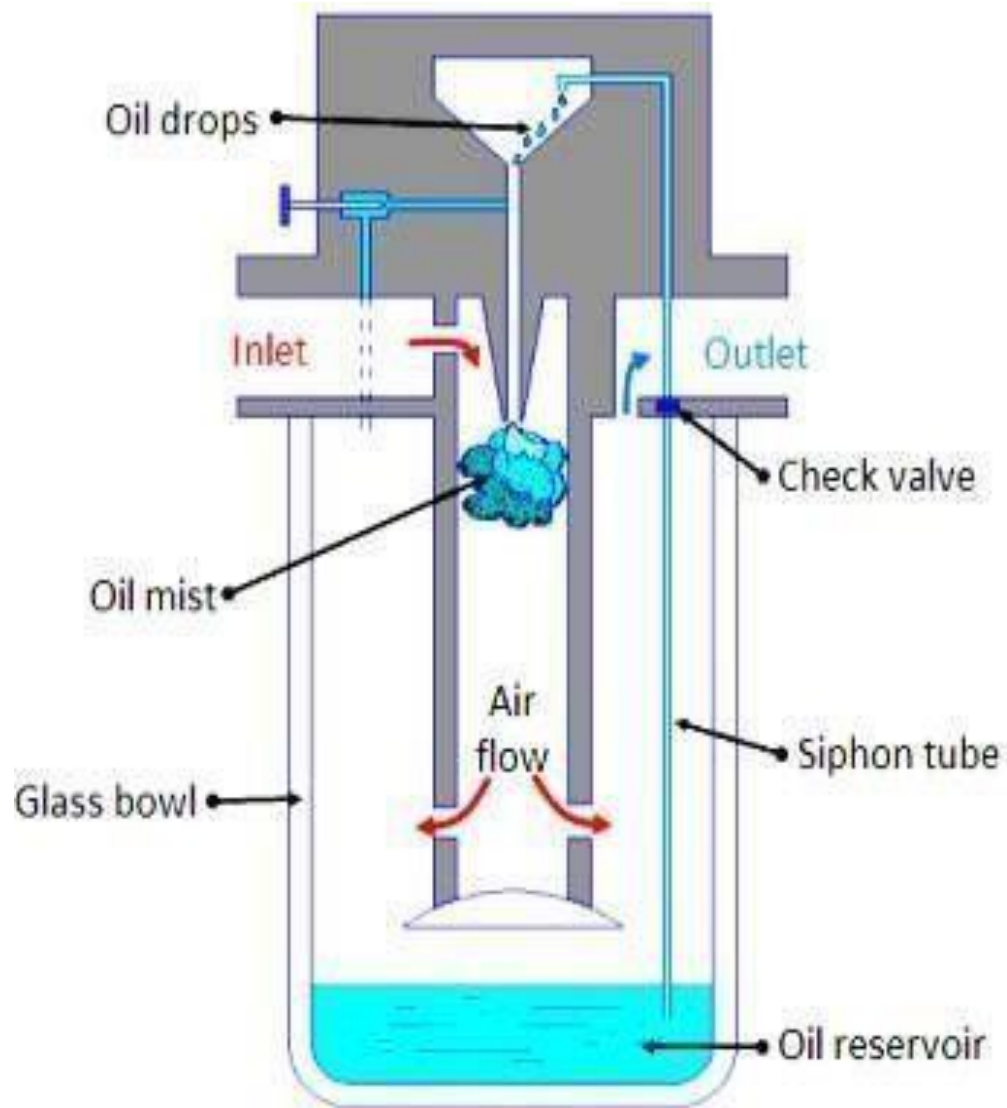

Fig14lubricator

The compressed air is first filtered and then passed through a lubricator in order to form a mist of oil and air to provide lubrication to the mating components.

Figure 14 shows the schematic of a typical lubricator.

The principle of working of venturimeter is followed in the operation of lubricator. The compressed air from the dryer enters in the lubricator. Its velocity increases due to a pressure differential between the upper and lower chamber (oil reservoir). Due to the low pressure in the upper chamber the oil is pushed into the upper chamber from the oil reservoir through a siphon tube with check valve.

The main function of the valve is to control the amount of oil passing through it. The oil drops inside the throttled zone where the velocity of air is much higher and this high velocity air breaks the oil drops into tiny particles.

Thus a mist of air and oil is generated. The pressure differential across chambers is adjusted by a needle valve. It is difficult to hold an oil mixed air in the air receiver as oil may settle down. Thus air is lubricated during secondary air treatment process. Low viscosity oil forms better mist than high viscosity oil and hence ensures that oil is always present in the air.

4. Pressure regulation

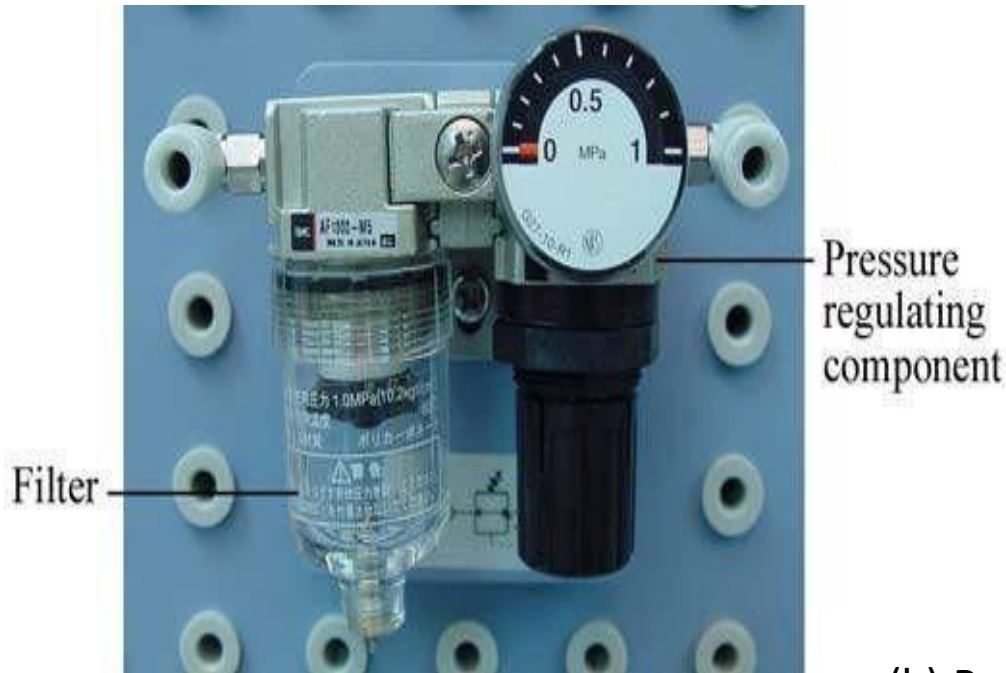

(a) Pressure regulating component

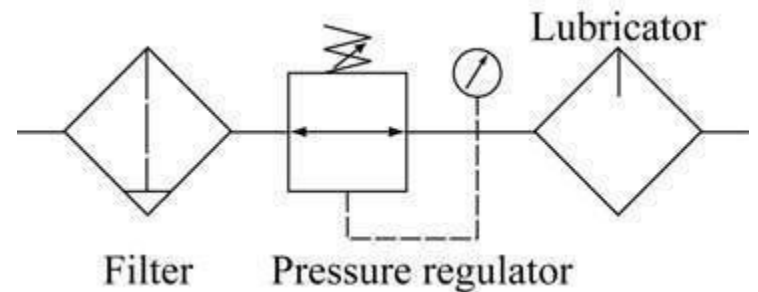

(b) Pneumatic symbols of the pneumatic components within a pressure regulating component

Pressure regulation

In pneumatics systems, during high velocity compressed airflow, there is flow-dependent pressure drop between the receiver and load (application). Therefore the pressure in the receiver is always kept higher than the system pressure. At the application site, the pressure is regulated to keep it constant. There are three ways to control the local pressure, these are shown in Figure

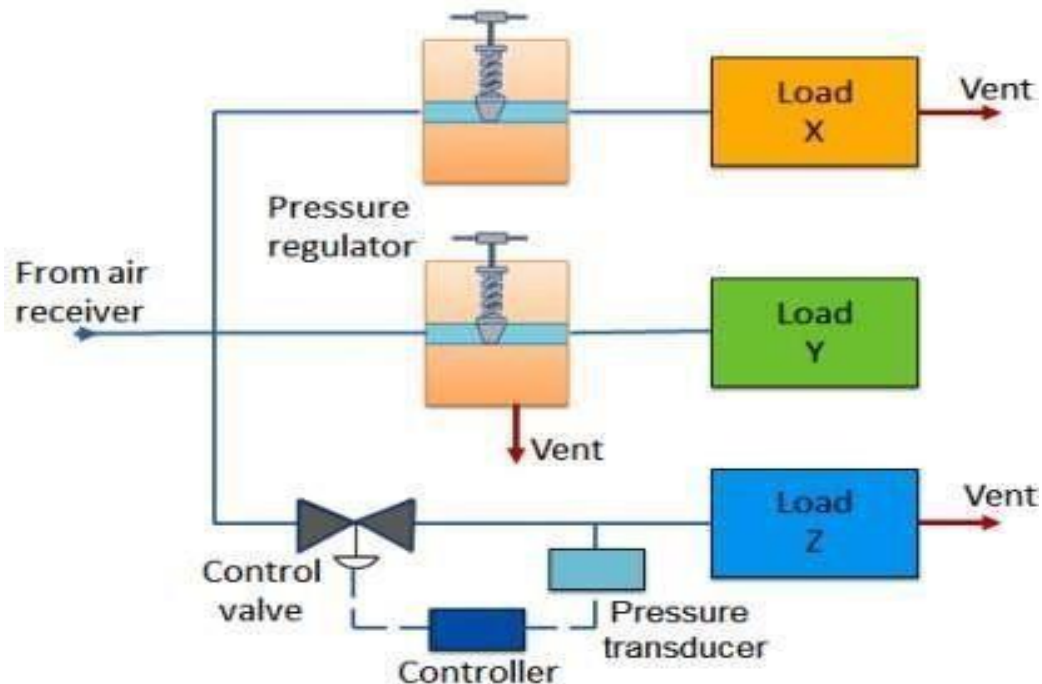

- In the first method, load X vents the air into atmosphere continuously. The pressure regulator restricts the air flow to the load, thus controlling the air pressure. In this type of pressure regulation, some minimum flow is required to operate the regulator. If the load is a dead end type which draws no air, the pressure in the receiver will rise to the manifold pressure. These type of regulators are called as 'non-relieving regulators', since the air must pass through the load.

- • In the second type, load Y is a dead end load. However the regulator vents the air into atmosphere to reduce the pressure. This type of regulator is called as 'relieving regulator'.

- • The third type of regulator has a very large load Z. Therefore its requirement of air volume is very high and can't be fulfilled by using a simple regulator. In such cases, a control loop comprising of pressure transducer, controller and vent valve is used. Due to large load the system pressure may rise above its critical value. It is detected by a transducer. Then the signal will be processed by the controller which will direct the valve to be opened to vent out the air. This technique can be also be used when it is difficult to mount the pressure regulating valve close to the point where pressure regulation is needed.

5. Reliefvalve

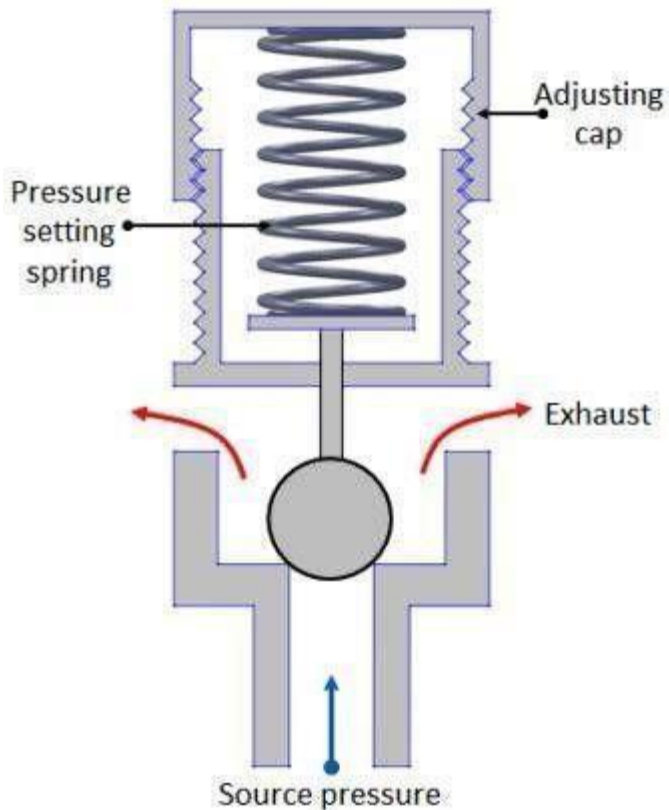

Reliefvalve

- Reliefvalveisthesimplesttypeofpressure regulating device. The schematic of its construction and working is shown in the Figure
- It is used as a backup device if the main pressure control fails. It consists of ball type valve held on to the valve seat by a springintension.Thespringtensioncanbe adjusted by using the adjusting cap.
- When the air pressure exceeds the spring tension pressure the ball is displaced from its seat,thus releasing the air andreducing the pressure.
- A relief is specified by its span of pressure between the cracking and full flow, pressure range and flow rate. Once the valve opens (cracking pressure), flow rate depends on the excess pressure. Once the pressure falls below the cracking pressure, the valve seals itself.

6. Non-relieving pressure regulator

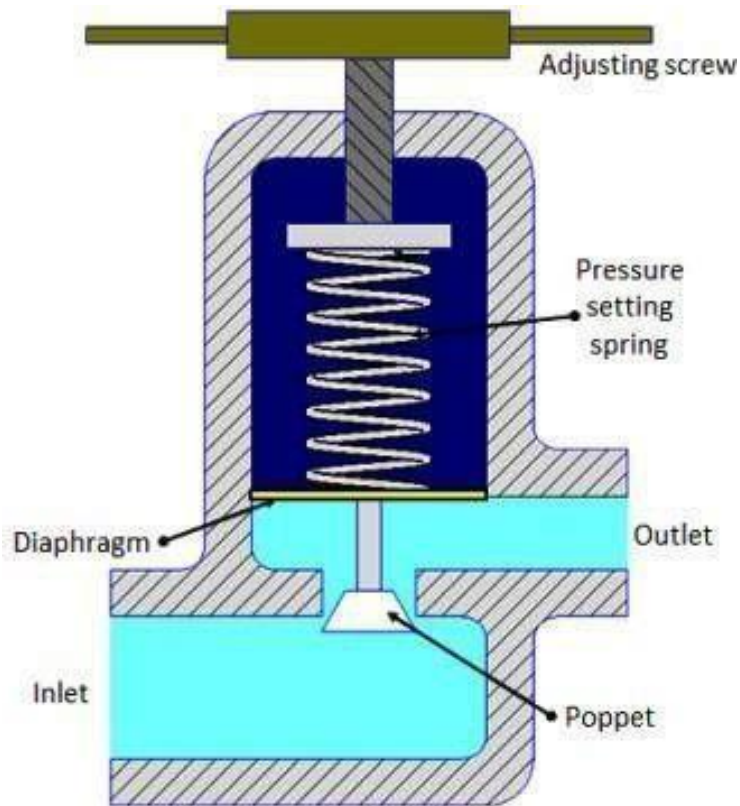

- In a non-relieving pressure regulator the outlet pressure is sensed by a diaphragm which is preloaded by a pressure setting spring.
- If outlet pressure is too low, the spring forces the diaphragm and poppet to move down thus opening the valve to admit more air and raise outlet pressure.
- If the outlet pressure is too high the air pressure forces the diaphragm up hence reduces the air flow and causing a reduction in air pressure.
- The air vents away through the load. At steady state condition the valve will balance the force on the diaphragm from the outlet pressure with the present force on the spring

7. Serviceunits

During the preparation of compressed air, various processes such as filtration, regulation and lubrication are carried out by individual components. The individual components are: separator/filter, pressure regulator and lubricator.

Preparatory functions can be combined into one unit which is called as 'service unit'. Figure symbolic representation of various processes involved in air preparation and the service unit.

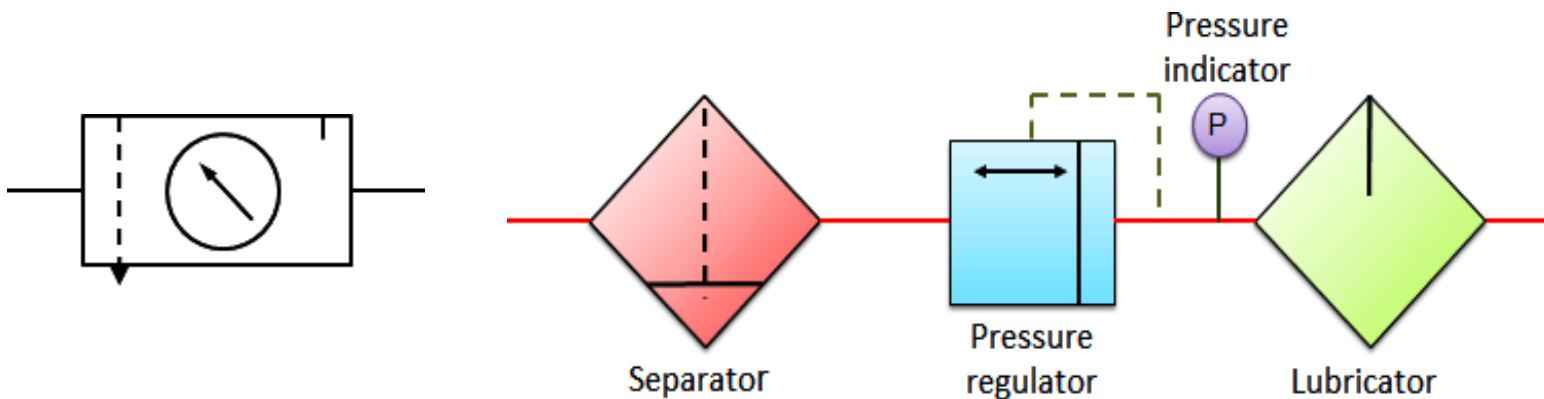

Fig.(a)Serviceunitcomponents

(b)Serviceunitsymbol

PneumaticSystems

Actuators

The consumption of compressed air

Examples of components that consume compressed air include execution components (cylinders), directional control valves and assistant valves.

(a) Execution component

Actuators

Actuators are output devices which convert energy from pressurized hydraulic oil or compressed air into the required type of action or motion. In general, hydraulic or pneumatic systems are used for gripping and/or moving operations in industry. These operations are carried out by using actuators.

Actuators can be classified into three types.

1. **Linear actuators:** These devices convert hydraulic/pneumatic energy into linear motion.
2. **Rotary actuators:** These devices convert hydraulic/pneumatic energy into rotary motion.

3. Actuators to operate flow control valves: these are used to control the flow and pressure of fluids such as gases, steam or liquid.

The construction of hydraulic and pneumatic linear actuators is similar. However they differ at their operating pressure ranges. Typical pressure of hydraulic cylinders is about 100 bar and of pneumatic system is around 10 bar.

1. Single acting cylinder



(a) Single acting cylinder

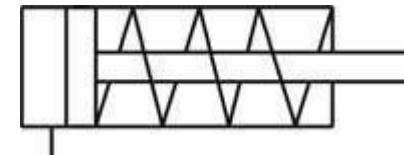

(b) Pneumatic symbol of a single acting cylinder

Single acting cylinder

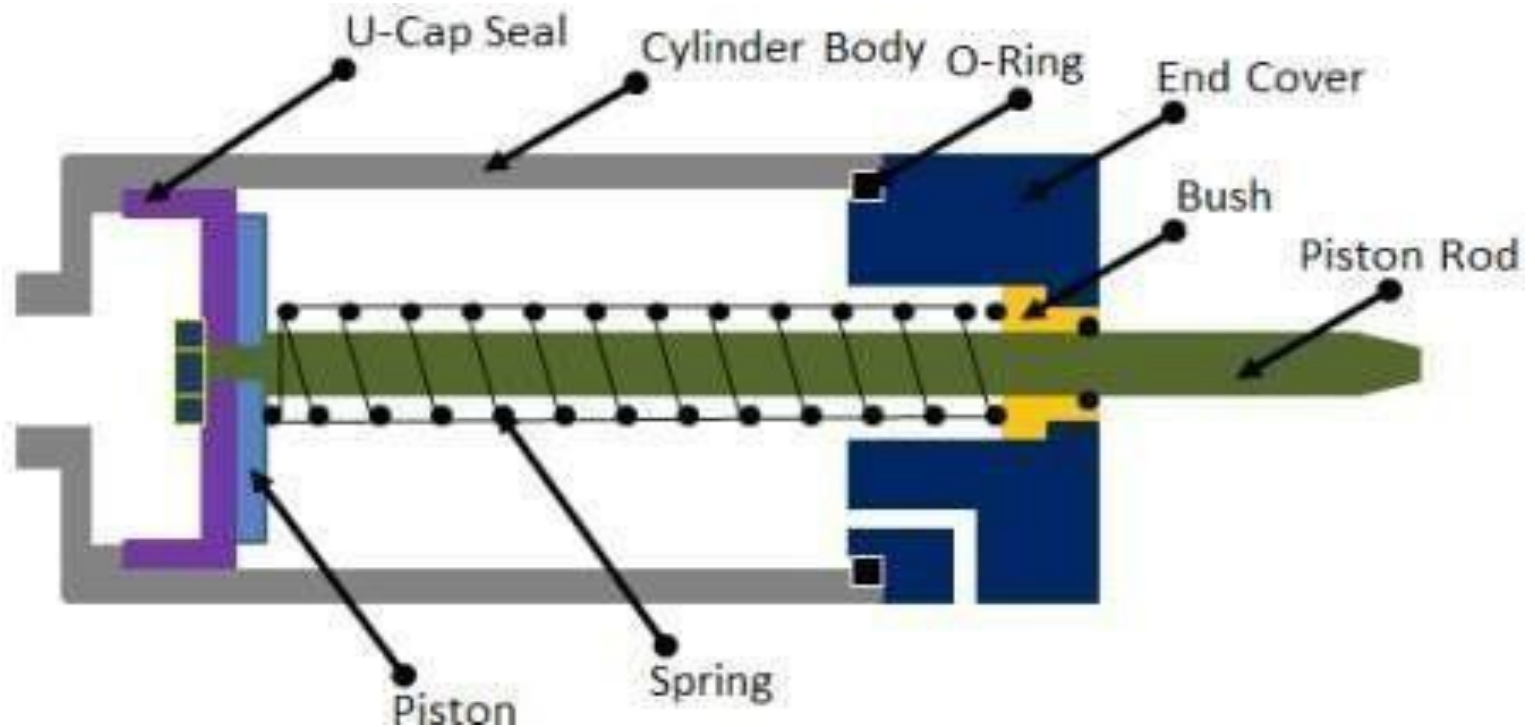

These cylinders produce work in one direction of motion hence they are named as single acting cylinders. Figure shows the construction of a single acting cylinder. The compressed air pushes the piston located in the cylindrical barrel causing the desired motion. The return stroke takes place by the action of a spring. Generally the spring is provided on the rod side of the cylinder.

2. Doubleacting cylinder



a) Doubleactingcylinder

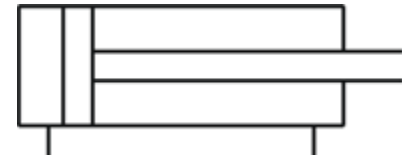

(b) Pneumaticsymbolofa
double acting cylinder

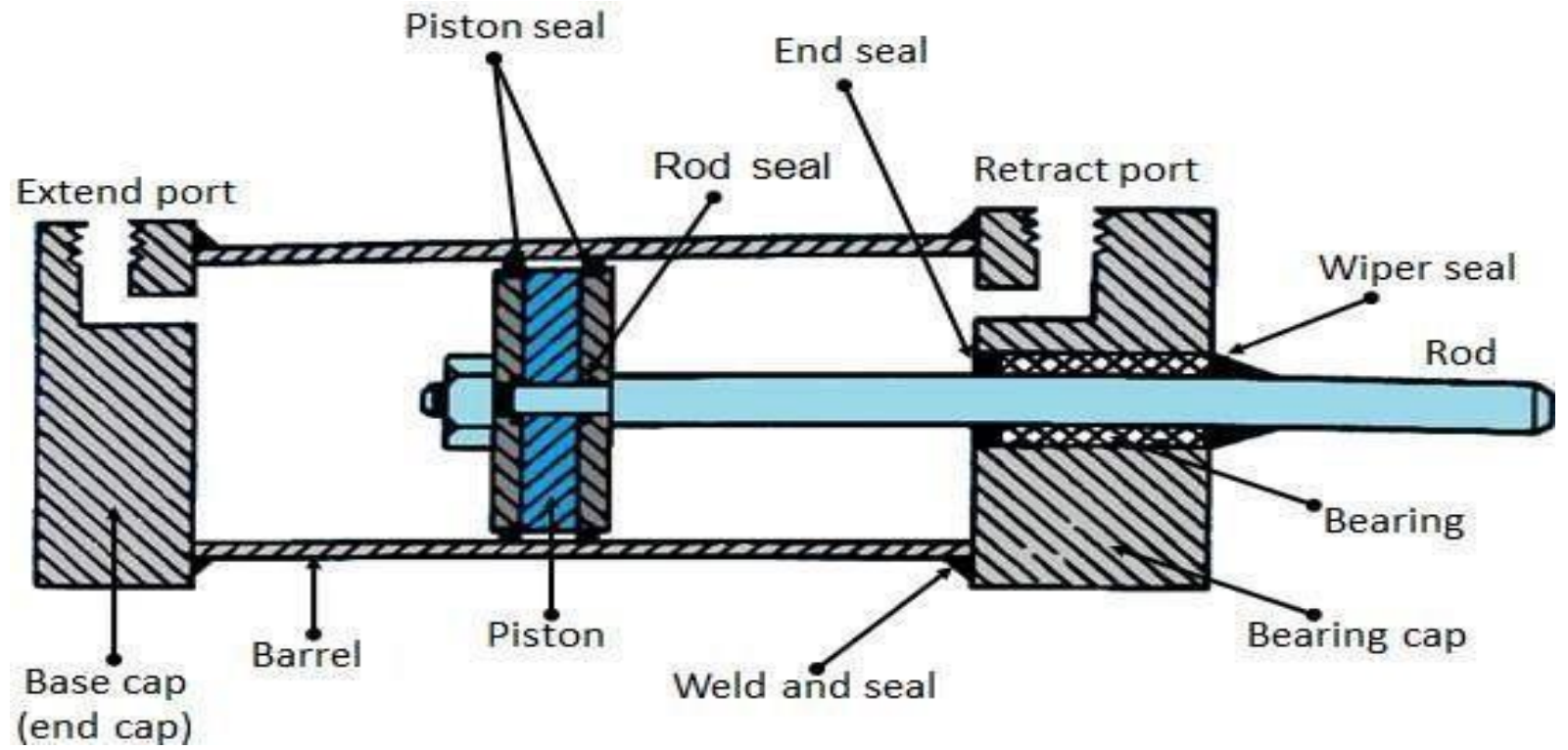

Doubleactingcylinder

- **The main parts of a hydraulic double acting cylinder are: piston, piston rod, cylinder tube, and end caps.**
- **These are shown in Figure The piston rod is connected to piston head and the other end extends out of the cylinder.**
- **The piston divides the cylinder into two chambers namely the rod end side and piston end side. The seals prevent the leakage of oil between these two chambers. The cylindrical tube is fitted with end caps. The pressurized oil, air enters the cylinder chamber through the ports provided. In the rod end cover plate, a wiper seal is provided to prevent the leakage of oil and entry of the contaminants into the cylinder.**
- **The combination of wiper seal, bearing and sealing ring is called as cartridge assembly. The end caps may be attached to the tube by threaded connection, welded connection or tie rod connection. The piston seal prevents metal to metal contact and wear of piston head and the tube. These seals are replaceable. End cushioning is also provided to prevent the impact with end caps.**

(b) Directional control valve

Directional control valves ensure the flow of air between air ports by opening, closing and switching their internal connections.

Their classification is determined by the number of ports, the number of switching positions, the normal position of the valve and its method of operation.

Common types of directional control valves include 2/2, 3/2, 5/2, etc. The first number represents the number of ports; the second number represents the number of positions.

A directional control valve that has five ports and two positions can be represented by the drawing in Fig. 8, as well as its own unique pneumatic symbol.

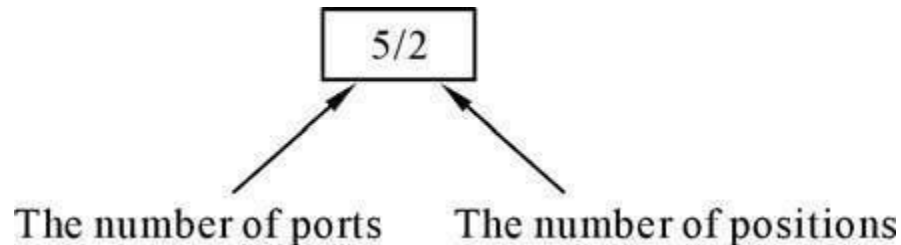

Fig.8 Describing a 5/2 directional control valve

(i) 2/2 Directional Control Valve

The 2/2 way valve has two ports and two positions (open, closed). The structure of a 2/2 directional control valve is very simple. It uses the thrust from the spring to open and close the valve, stopping compressed air from flowing towards working tube 'A' from air inlet 'P'. When a force is applied to the control axis, the valve will be pushed open, connecting 'P' with 'A' (Fig.). The force applied to the control axis has to overcome both air pressure and the repulsive force of the spring. The control valve can be driven manually or mechanically, and restored to its original position by the spring.



(a) 2/2 directional control valve

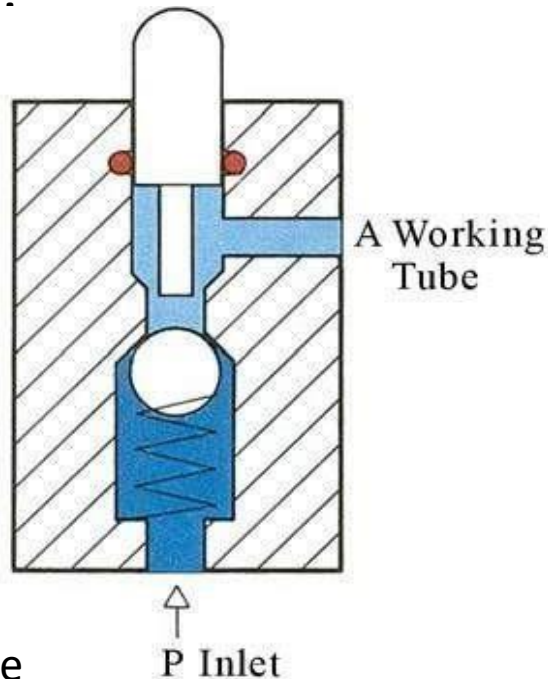

(b) Crosssection

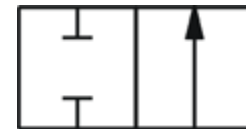

(c) Pneumatics symbol of a 2/2 directional control valve

(ii) 3/2 Directional control valve

A 3/2 directional control valve can be used to control a single acting cylinder (Fig. 10). The open valves in the middle will close until 'P' and 'A' are connected together. Then another valve will open the sealed base between 'A' and 'R' (exhaust). The valves can be driven manually, mechanically, electrically or pneumatically. 3/2 directional control valves can further be divided into two classes: Normally open type (N.O.) and normally closed type (N.C.) (Fig. 11).

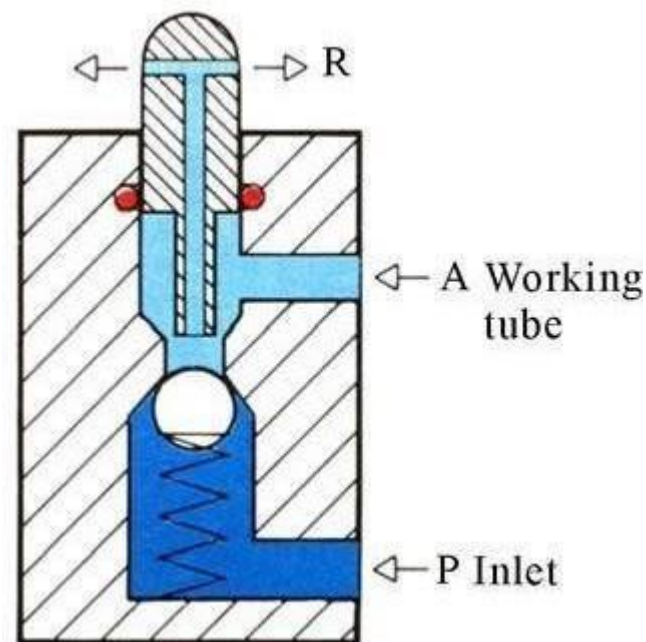

Fig.10(a)3/2directionalcontrolvalve(b)Crosssection

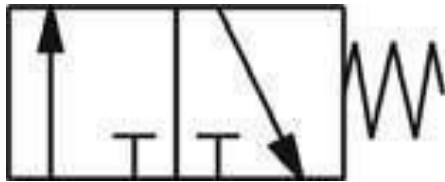
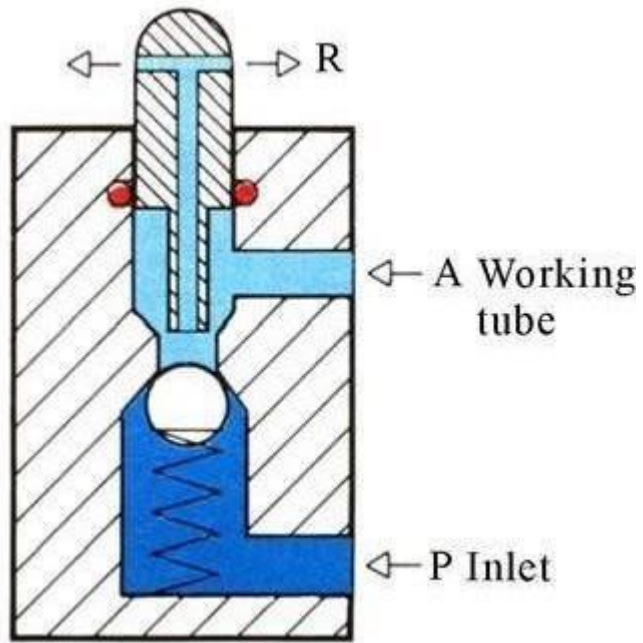
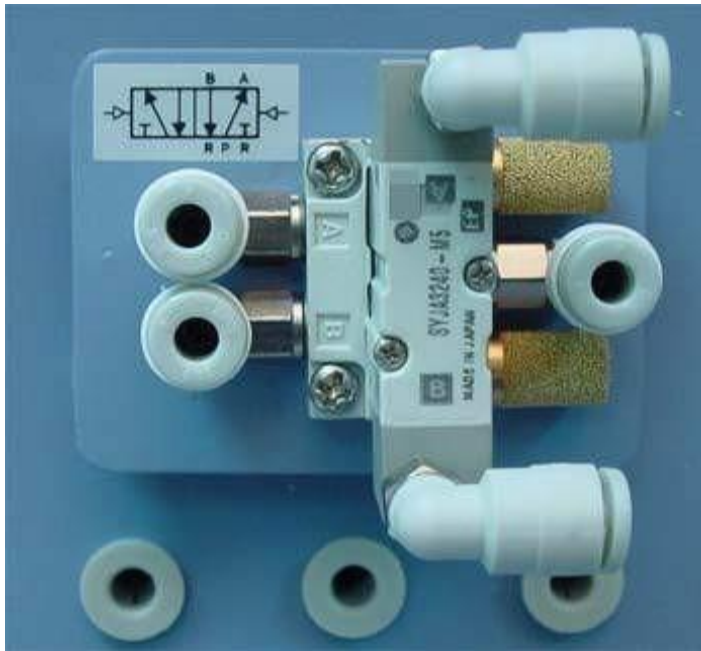
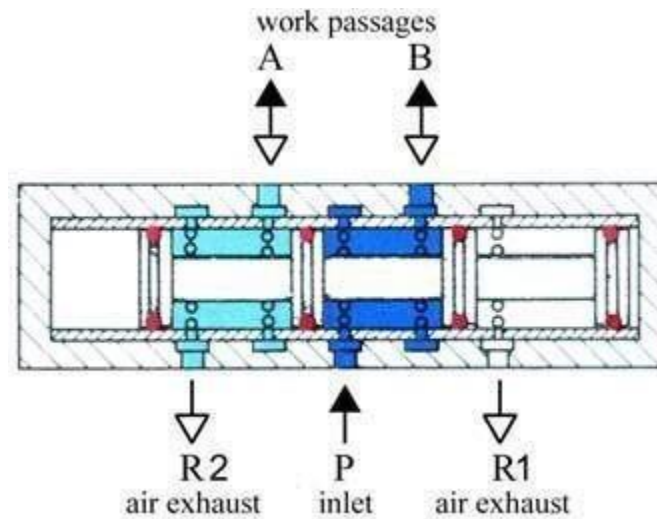

Fig.11 Pneumaticsymbols

(iii) 5/2 Directional control valve



(a) 5/2 directional control valve



b) Cross section



(c) Pneumatic symbol

When a pressure pulse is input into the pressure control port 'P', the spool will move to the left, connecting inlet 'P' and work passage 'B'. Work passage 'A' will then make a release of air through 'R1' and 'R2'. The directional valves will remain in this operational position until signals of the contrary are received. Therefore, this type of directional control valve is said to have the function of 'memory'.

(c) Control valve

A control valve is a valve that controls the flow of air. Examples include non-return valves, flow control valves, shuttle valves, etc.

(i) Non-return valve

A non-return valve allows air to flow in one direction only. When air flows in the opposite direction, the valve will close. Another name for non-return valve is poppet valve (Fig. 13).

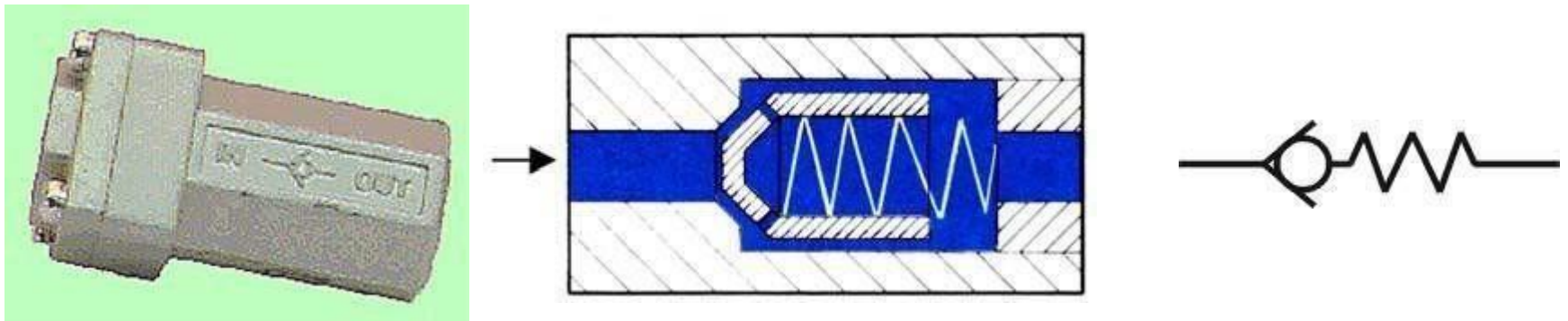

Fig.13(a)Non-returnvalve(b)Crosssection(c)Pneumaticsymbol

(ii) Flowcontrolvalve

A flowcontrol valve is formed by a non-return valve and a variable throttle (Fig.14).

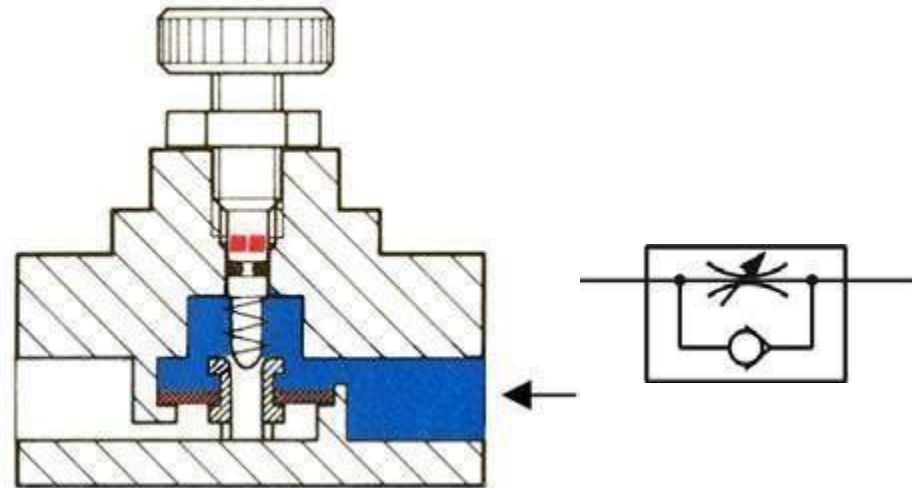

Fig.14(a)Flowcontrolvalve(b)Crosssection(c)Pneumaticsymbol

(iii) Shuttlevalve

Shuttlevalves are also known as double control or single control non-return valves. A shuttle valve has two air inlets 'P1' and 'P2' and one air outlet 'A'. When compressed air enters through 'P1', the sphere will seal and block the other inlet 'P2'. Air can then flow from 'P1' to 'A'. When the contrary happens, the sphere will block inlet 'P1', allowing air to flow from 'P2' to 'A' only.

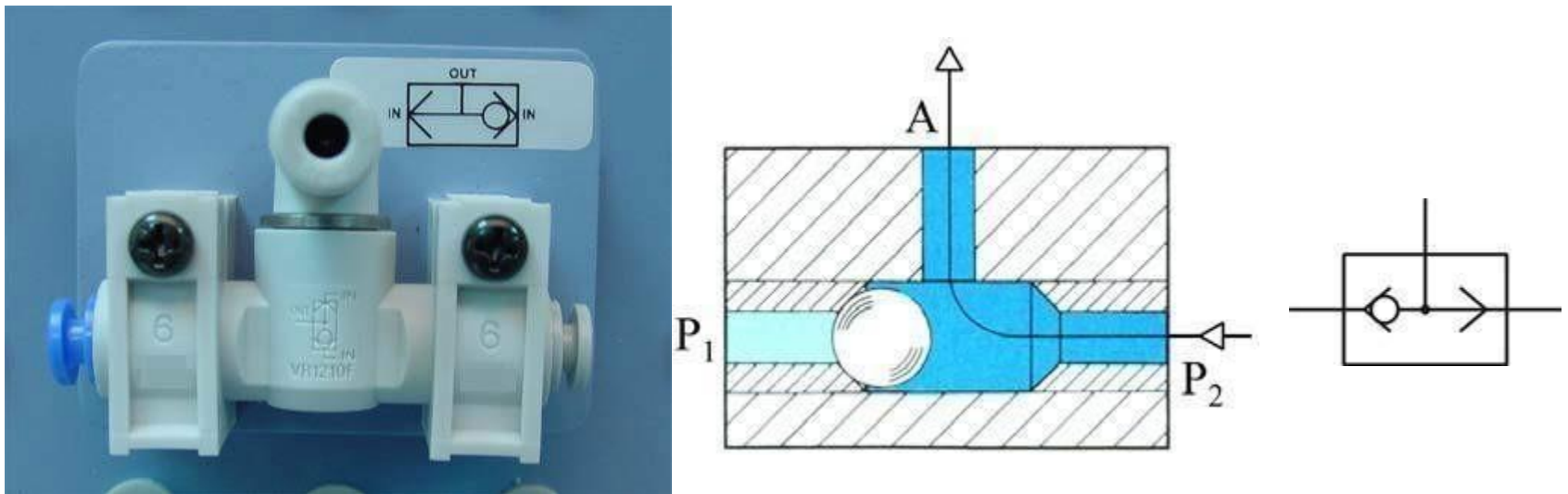
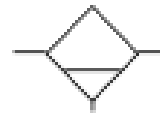

Fig.15(a) Shuttle valve (b) Cross section (c) Pneumatic symbol

Conditioners

- **Water separator with manual drain**



- **Water separator with automatic drain**

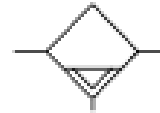

- **Filter with manual drain**

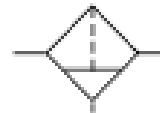

- **Filter with automatic drain**

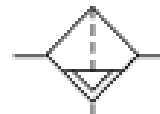

- **Lubricator**

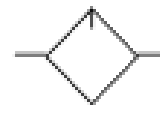

Conditioners

- **Dryer**

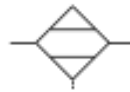

- **Cooler with and without coolant flow lines**

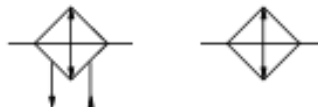

- **Heater**

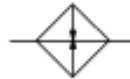

- **Combined heater / cooler**



Plant

- **Compressor and electric motor**

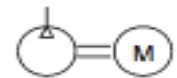

- **Air receiver**



- **Isolating valve**



- **Air inlet filter**



Pressure regulators

- A pressure regulator symbol represents a normal state with the spring holding the regulator valve open to connect the supply to the outlet.
- The dotted line represents the feedback, this opposes the spring and can vary the flow through the valve from full flow, through shut off, to exhaust. The symbol is usually drawn in only this one state. The flow path can be imagined to hinge at the right hand end to first shut off the supply then connect to the exhaust.

- Adjustable Regulator simplified
- Adjustable Regulator with pressure gauge simplified

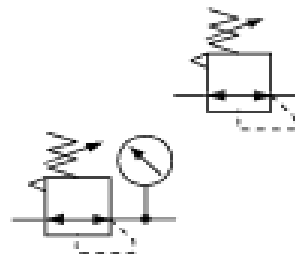

Filter Regulator Lubricator

- **FRL Combined unit**

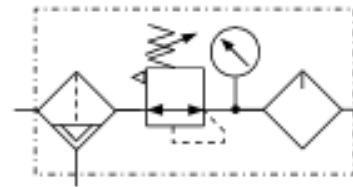

- **FRL Simplified symbol**



Pressure relief valves

- A pressure relief valve symbol represents a normal state with the spring holding the valve closed.
- The dotted line represents feed-forward, this opposes the spring and can be imagined to lift the flow path. When the pressure reaches an excess value the flow path will line up with the ports and flow air to relief.

- Adjustable relief valve simplified

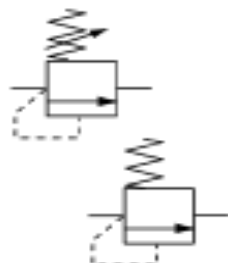

- Preset relief valve simplified



Single acting

- Single acting sprung instroked
- Single acting sprung outstroked
- Single acting sprung instroked magnetic *
- Single acting sprung outstroked magnetic *

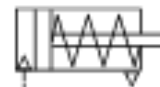

Double acting

- Double acting adjustable cushions



- Double acting through rod

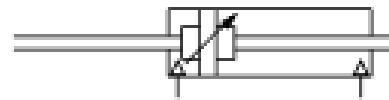

- Double acting magnetic *

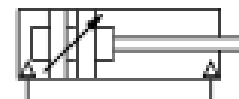

- Double acting rodless *

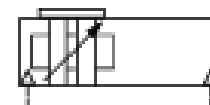

Simplified cylinder symbols

- **Single acting load returns**

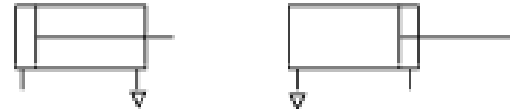

- **Single acting spring returns**



- **Double acting non cushioned**

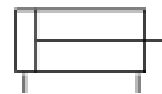

- **Double acting adjustable cushions**

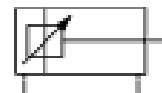

- **Double acting through rod**

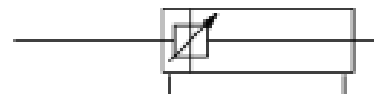

Valve symbol structure

- The operator for a particular state is illustrated against that state

Operated state
produced by
pushing a button

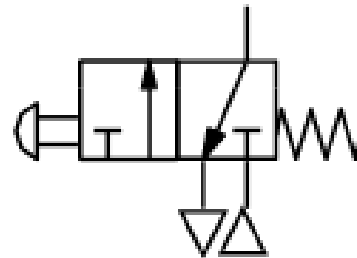

Normal state
produced by
a spring

Valve symbol structure

- A 5/2 valve symbol is constructed in a similar way. A picture of the valve flow paths for each of the two states is shown by the two boxes. The 5 ports are normally an inlet, 2 outlets and 2 exhausts



Valve symbol structure

- The boxes can be joined at either end but the operator must be drawn against the state that it produces. The boxes can also be flipped
- A variety of symbol patterns are possible

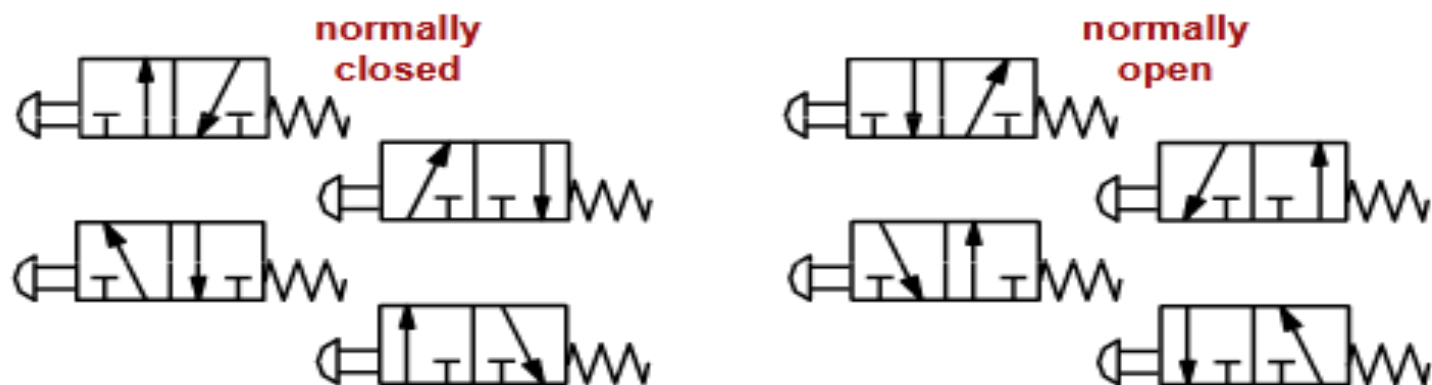

Valve functions

Basic valves before operators are added

Function 2/2



Function 3/2



Examples, push button operated with spring return

Normal position

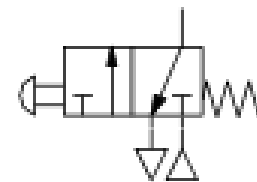
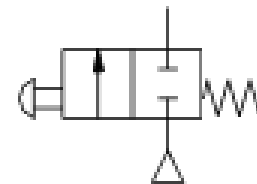

Valve functions

Basic valves before operators are added

Function 2/2

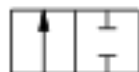

Function 3/2

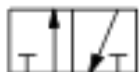

Examples, push button operated with spring return

Operated position

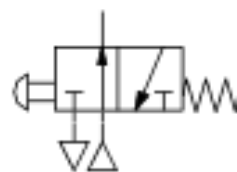
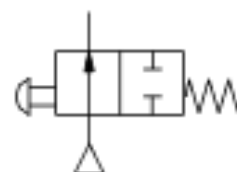

Valves 5/3

- All valves types shown in the **normal position**

- Type 1. All ports sealed

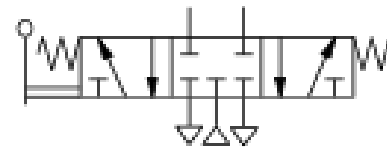

- Type 2. Outlets to exhaust

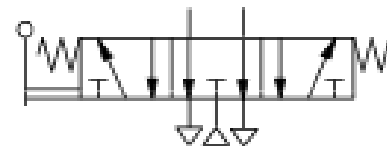

- Type 3. Supply to outlets

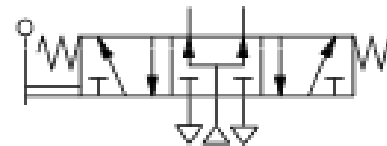

Valves 5/3

- All valves types shown in the **first operated position**

- Type 1. All ports sealed

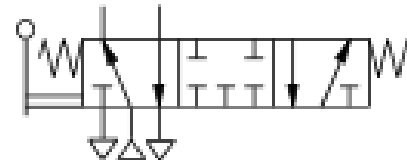

- Type 2. Outlets to exhaust

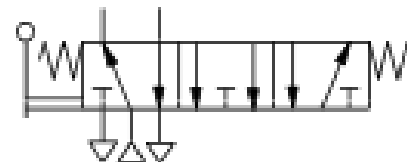

- Type 3. Supply to outlets

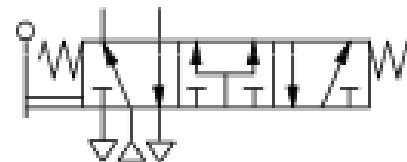

Valves 5/3

- All valves types shown in the **second operated position**

- Type 1. All ports sealed

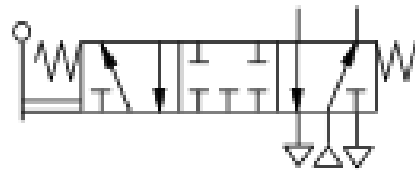

- Type 2. Outlets to exhaust

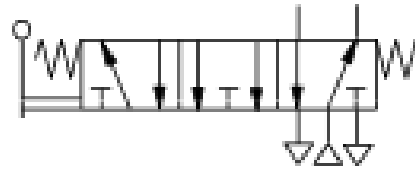

- Type 3. Supply to outlets

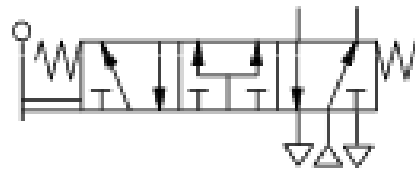

Manual

General manual



Lever



Push button

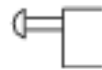

Pedal



Pull button

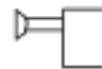

Treadle



Push/pull button

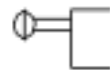

Rotary knob

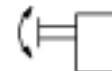

Valve Symbols, Flow Paths and Ports

2 position, 2
way, 2 ported

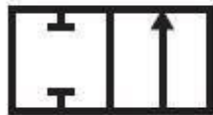

2 position, 3
way, 3 ported



2 position, 4
way, 4 ported



Actuator Symbols

Manual

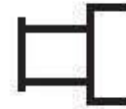

Push Button

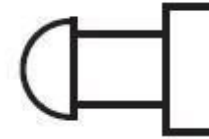

Lever



3 position, 4
way, 4 ported,
Center Closed



Foot Operated



2 position, 4
way, 5 ported



Mechanical



3 position, 4
way, 5 ported



Detent



Simple Pneumatic Valves

Check Valve



Flow Control, 1 direction



Relief Valve

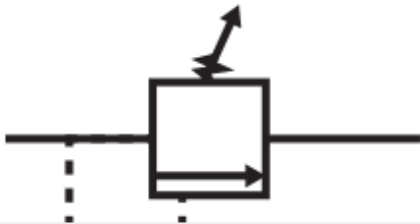

Solenoid



Internal Pilot



External Pilot



Lines

Main Line



Pilot Line



Piloted
Solenoid *with*
Manual
Override

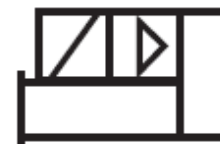

Piloted
Solenoid *and*
Manual
Override



Lever with
Spring



Exhaust Line
or Control Line



Lines Crossing

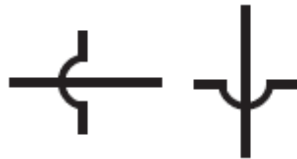

Lines
Connecting



Solenoid with
Spring Return



Miscellaneous

Accumulator



Air Dryer



Air Motor (One Direction Flow)

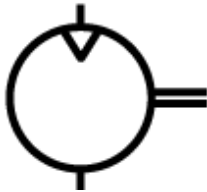

Differential Pressure

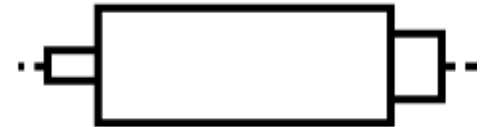

Direction of Flow



Lubricator



Air Motor (Two Direction Flow)

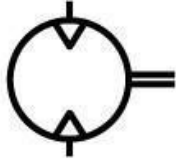

Check Valve (Spring Loaded)



Compressor

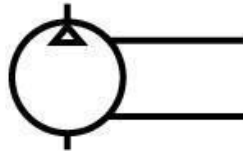

Filter

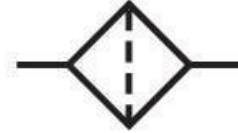

Filter (Automatic Drain)



Filter (Manual Drain)

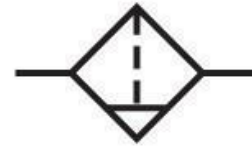

Cylinder (Spring Return)

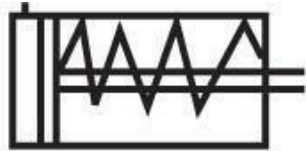

Cylinder Double Acting

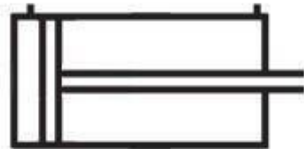

Cylinder Double Acting (Double Rod)



Fixed Restriction

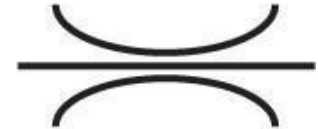

Flow Meter

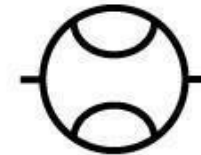

Cylinder
Double Acting
(Double Rod)



Cylinder
Double Acting
(Single Fixed
Cushion)



Cylinder
Double Acting
(Two
Adjustable
Cushions)



4 Principles of pneumatic control

(a) Pneumatic circuit

Pneumatic control systems can be designed in the form of pneumatic circuits. A pneumatic circuit is formed by various pneumatic components, such as cylinders, directional control valves, flow control valves, etc. Pneumatic circuits have the following functions:

1. To control the injection and release of compressed air in the cylinders.
2. To use one valve to control another valve.

(b) Pneumatic circuit diagram

A pneumatic circuit diagram uses pneumatic symbols to describe its design. Some basic rules must be followed when drawing pneumatic diagrams

(i) Basic rules

1. A pneumatic circuit diagram represents the circuit in static form and assumes there is no supply of pressure. The placement of the pneumatic components on the circuit also follows this assumption.
2. The pneumatic symbol of a directional control valve is formed by one or more squares. The inlet and exhaust are drawn underneath the square, while the outlet is drawn on the top. Each function of the valve (the position of the valve) shall be represented by a square. If there are two or more functions, the squares should be arranged horizontally (Fig. 16).



**Fig173/2directionalcontrolvalve
(normally closed type)**

3. Arrows "↓ ↖" are used to indicate the flow direction of air current. If the external port is not connected to the internal parts, the symbol "⊥" is used. The symbol "⊙" underneath the square represents the air input, while the symbol "∇" represents the exhaust. Fig. 17 shows an example of a typical pneumatic valve.

The pneumatic symbols of operational components should be drawn on the outside of the squares. They can be divided into two classes: mechanical and manual (Fig. 18 and 19).

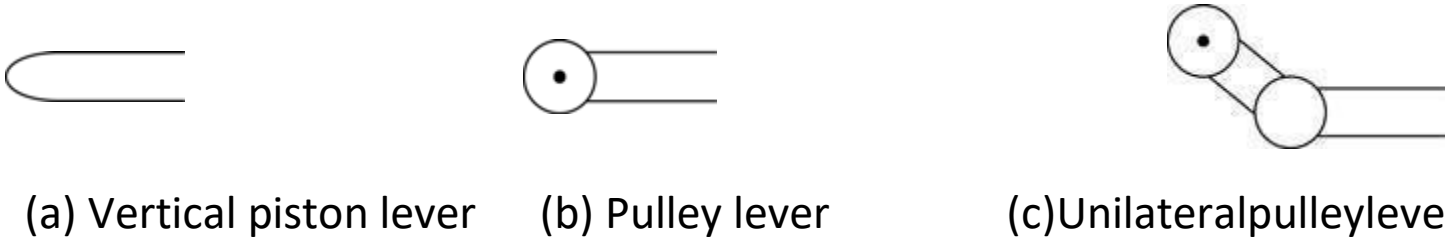

Fig. 18 Mechanically operated pneumatic components

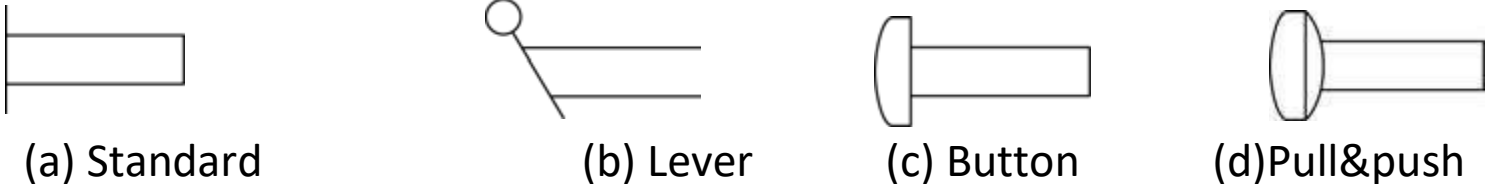

Fig. 19 Manually operated pneumatic components

5. Pneumatic operation signal pressure lines should be drawn on one side of the squares, while triangles are used to represent the direction of air flow (Fig. 20).

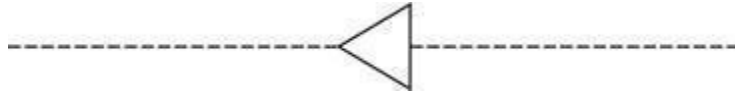
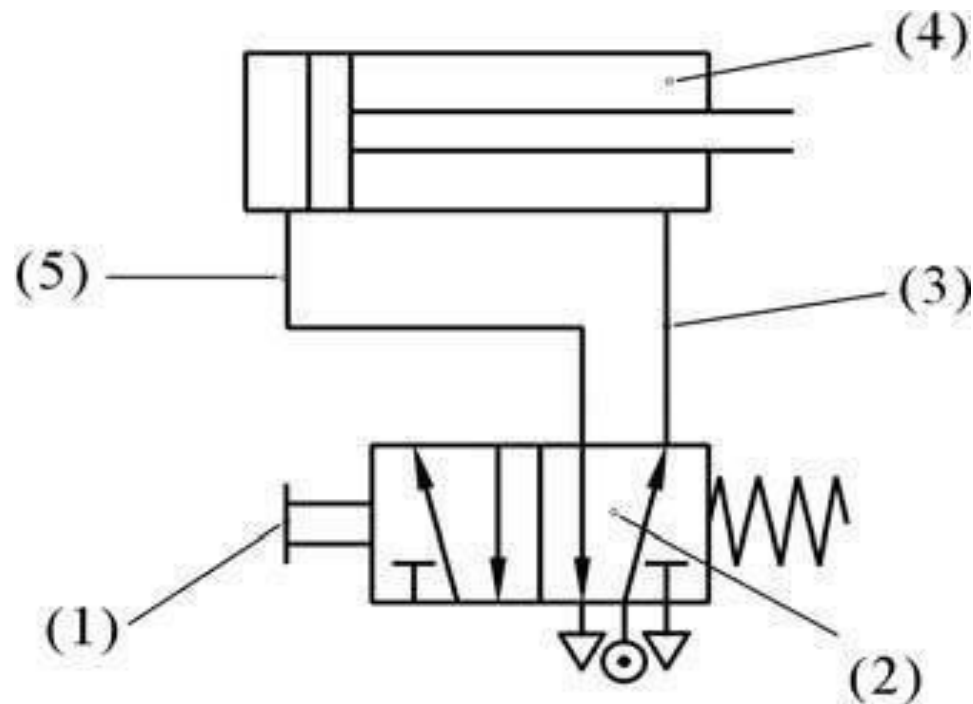

Fig.20 Pneumatic operation signal pressure line

(ii) Basic principles

Fig.21 shows some of the basic principles of drawing pneumatic circuit diagrams, the numbers in the diagram correspond to the following points:



- 1. When the manual switch is not operated, the spring will restore the valve to its original position.**
- 2. From the position of the spring, one can deduce that the block is operating. The other block will not operate until the switch is pushed.**
- 3. Air pressure exists along this line because it is connected to the source of compressed air.**
- 4. As this cylinder cavity and piston rod are under the influence of pressure, the piston rod is in its restored position.**
- 5. The rear cylinder cavity and this line are connected to the exhaust, where air is released.**

(iii) The setting of circuit diagrams

When drawing a complete circuit diagram, one should place the pneumatic components on different levels and positions, so the relations between the components can be expressed clearly. This is called the setting of circuit diagrams.

A circuit diagram is usually divided into three levels: power level, logic level and signal input level (Fig.22).

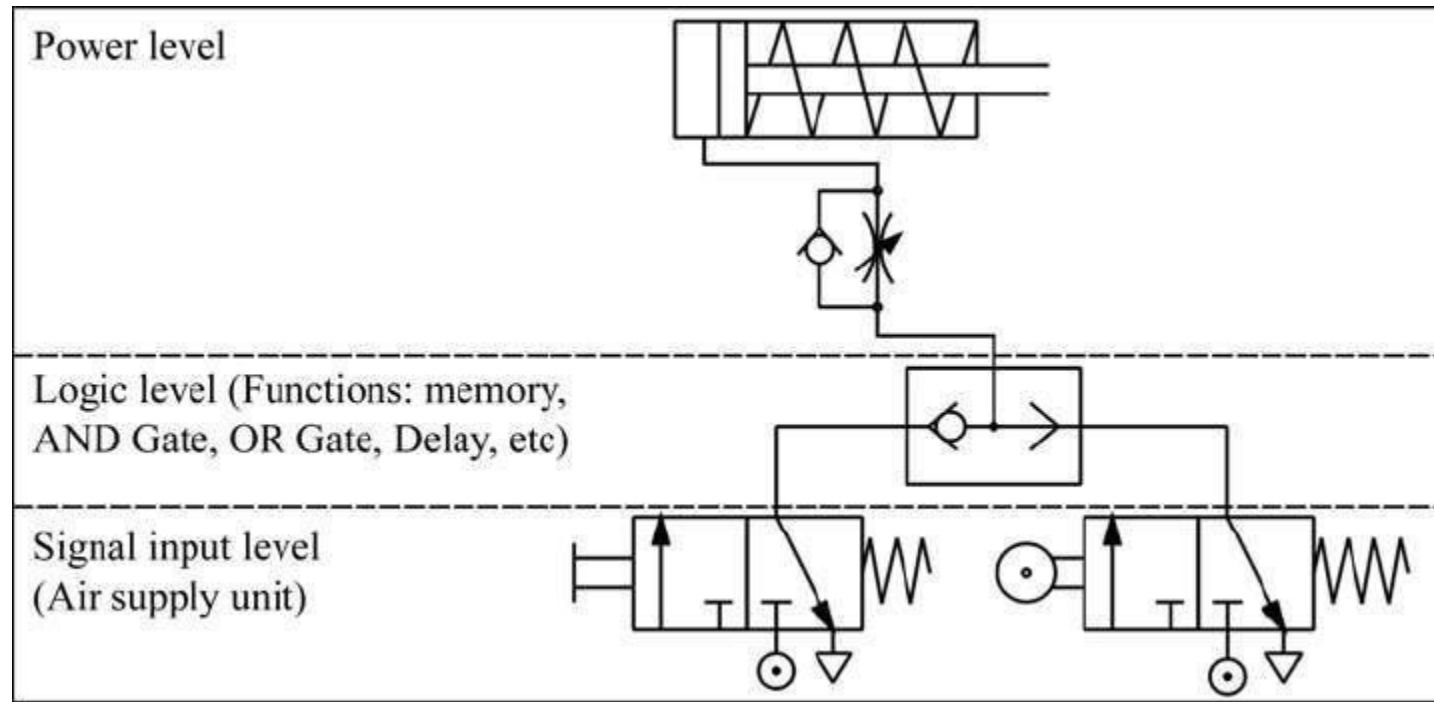
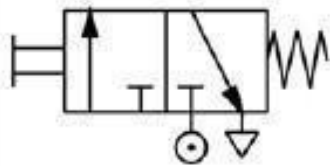

Fig.22 Power level, logic level and signal input level

The basic rules of circuit diagram setting are as follows:

1.



In a pneumatic circuit, the flow of energy is from the bottom to the top. Therefore, the air supply unit should be put at the bottom left corner.

2.

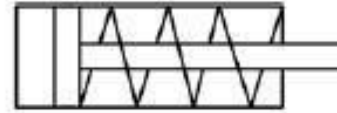

The work cycle should be drawn from left to right. The first operating cylinder should be placed at the upper left corner.

3.

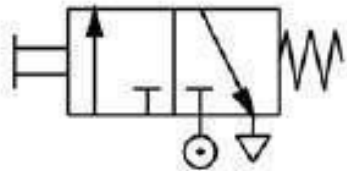
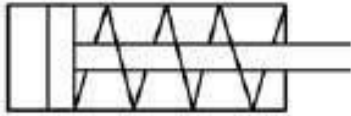

Power control valves should be drawn directly under the cylinder controlled by them, forming a power unit.

4.

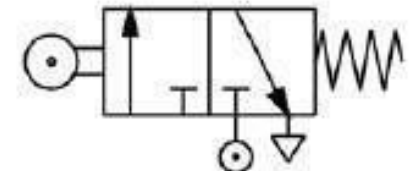
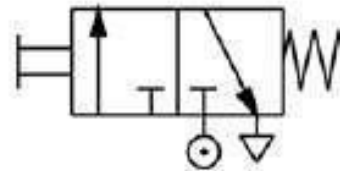
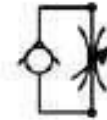
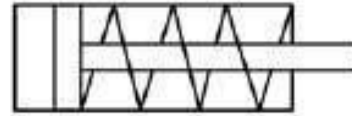

Control cylinders and operational valves (signal components) driven by power control valves should be placed at the lower levels of the diagram.

5.

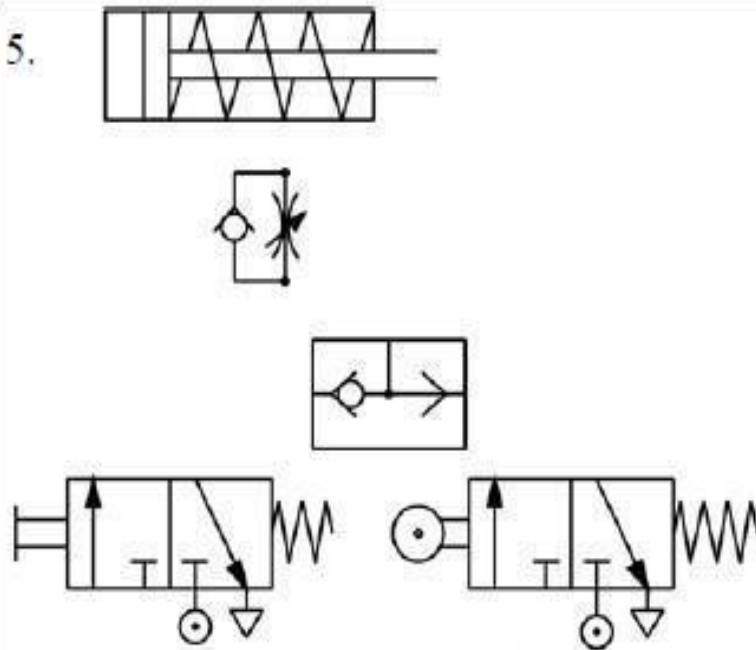

Assistance valves, such as those with logic functions (for example, memory, 'AND', 'OR', 'NOT', delay, etc), can be put between the pneumatic components and the power control valves.

6.

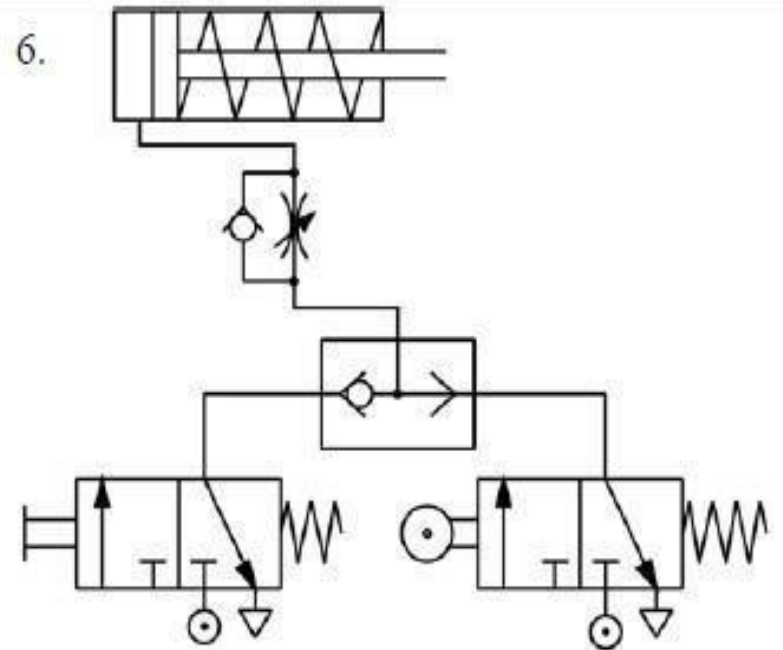

Use the line which represents the connecting pipe to connect all the air supply unit and the pneumatic components to complete the pneumatic circuit. Check carefully the circuit and the logic of the operation before use to avoid any accident.

Pneumatic circuit to operate single acting cylinder :

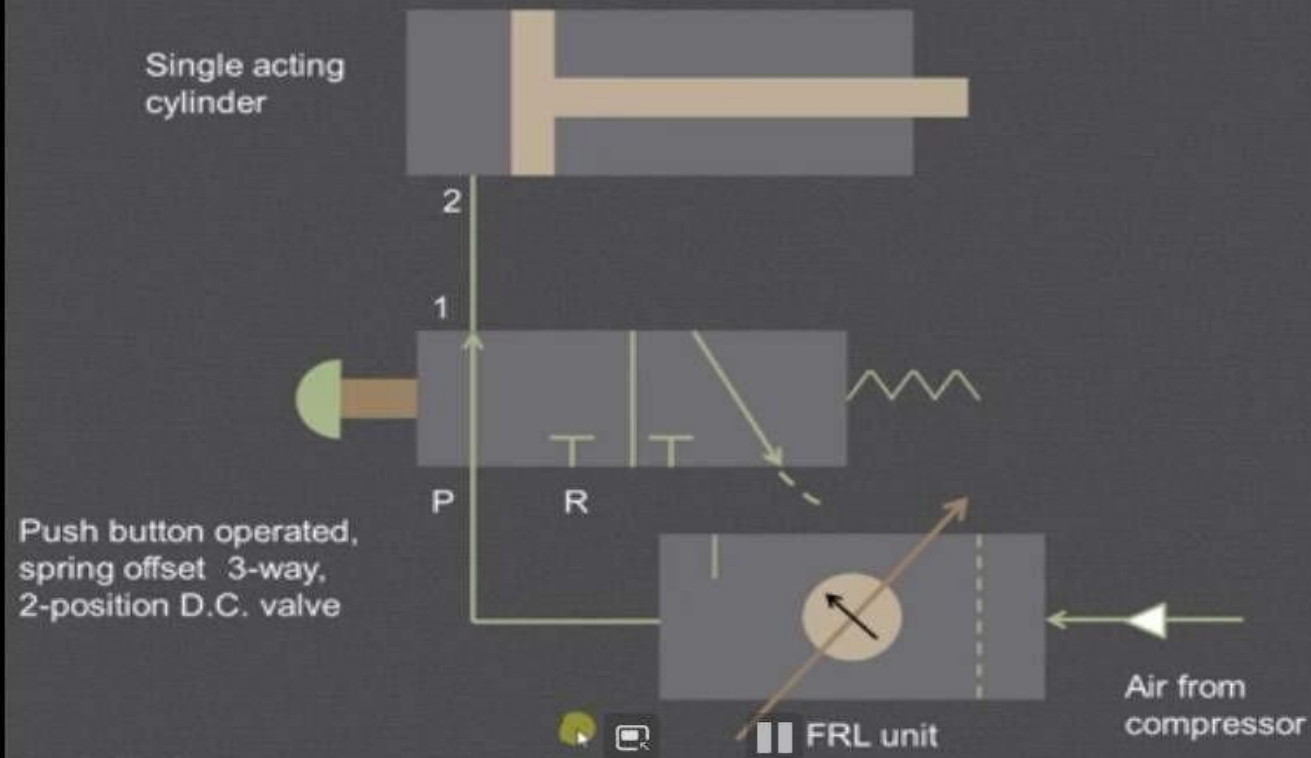

PNEUMATIC CIRCUIT

DIRECT CONTROL OF DOUBLE ACTING CYLINDER

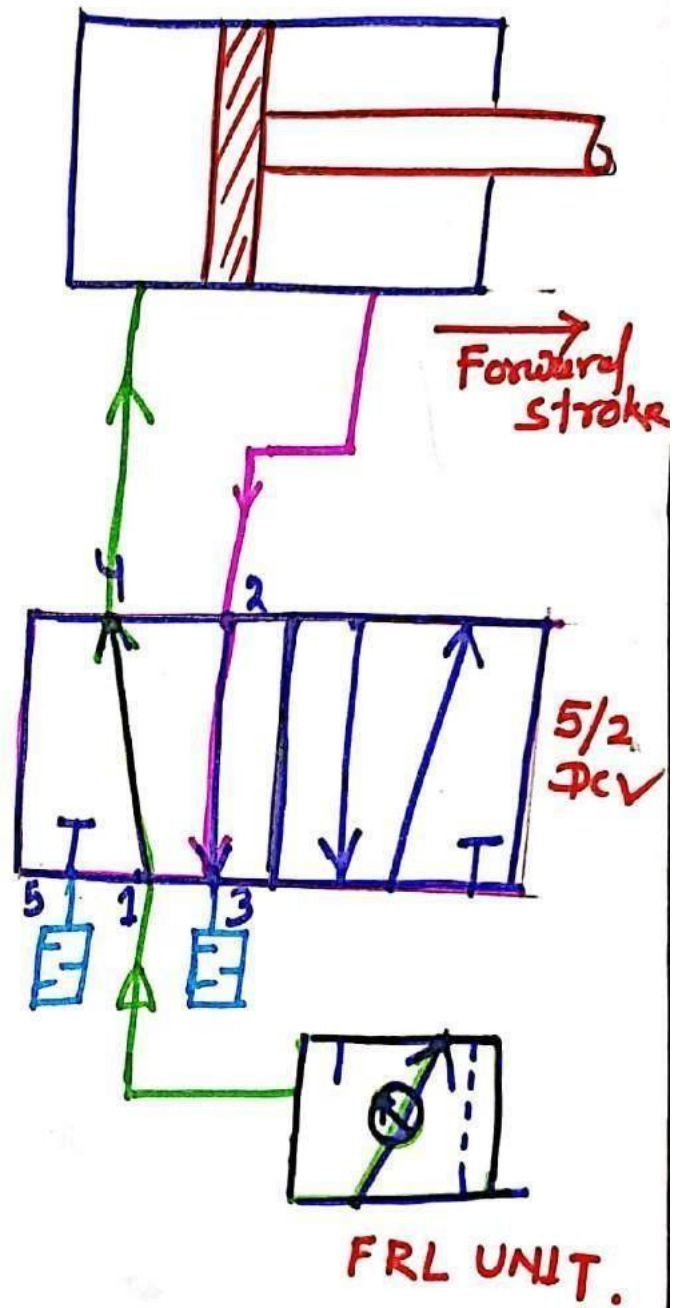
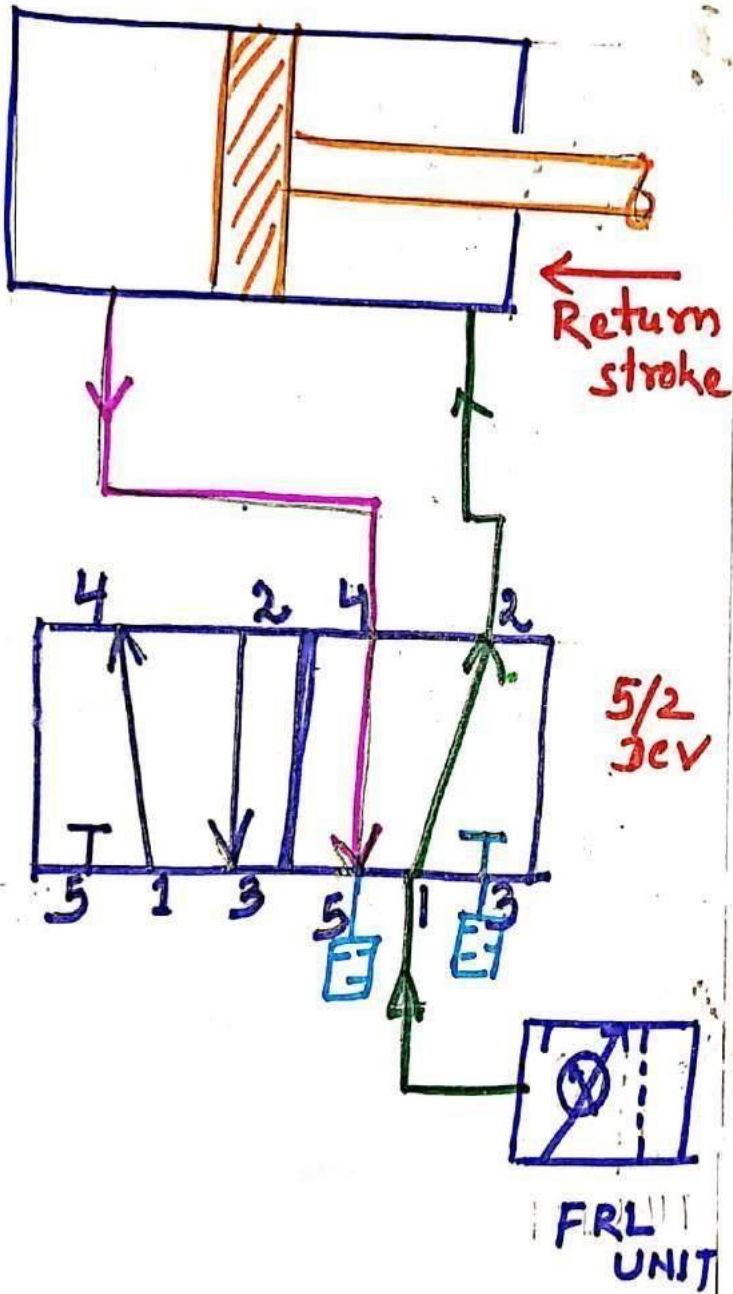

OPERATION OF DOUBLE ACTING CYLINDER WITH METERING IN CIRCUIT.

Metering IN

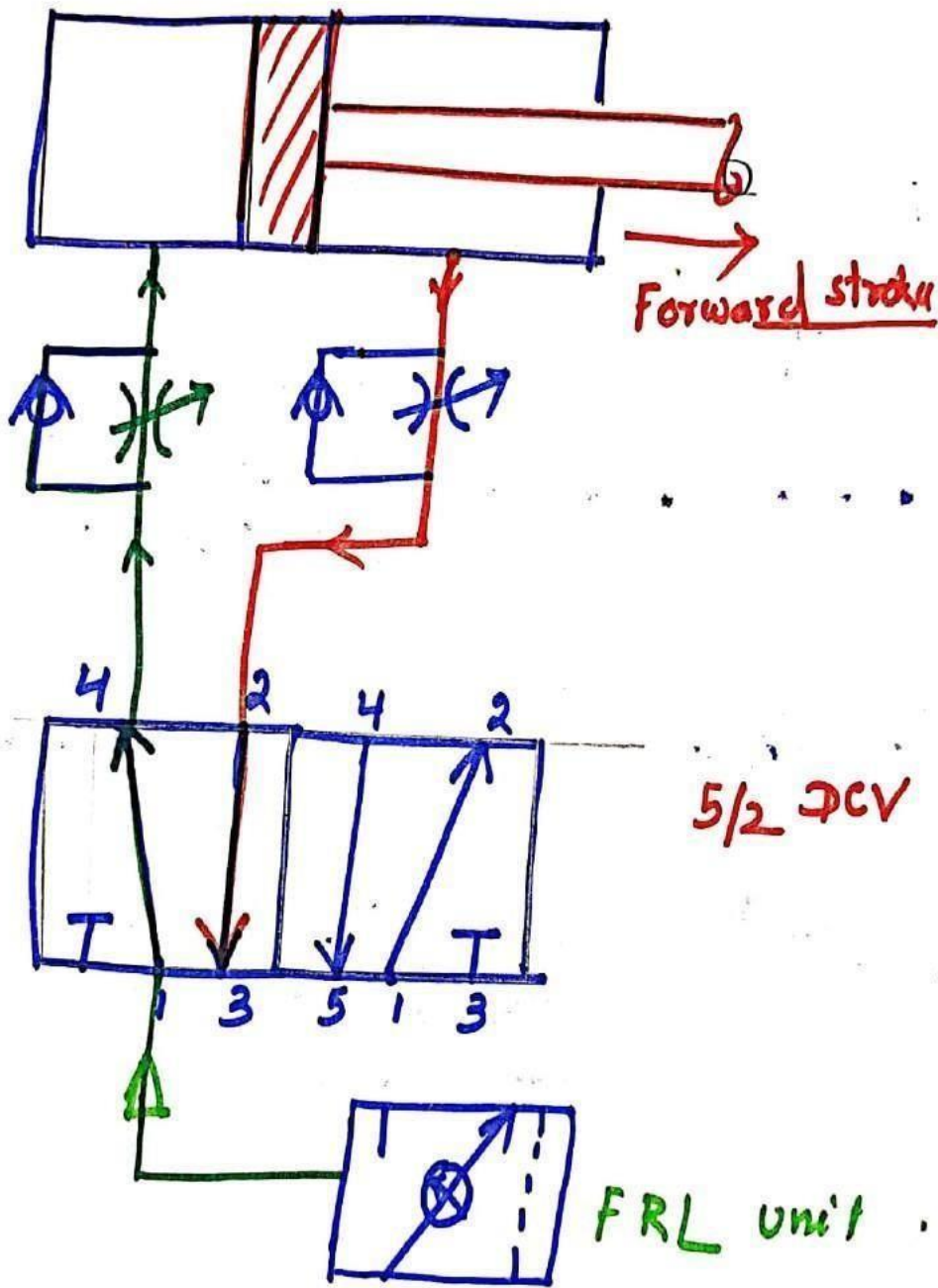

OPERATION OF DOUBLE ACTING CYLINDER WITH METERING
OUT CIRCUIT:

Metering OUT.

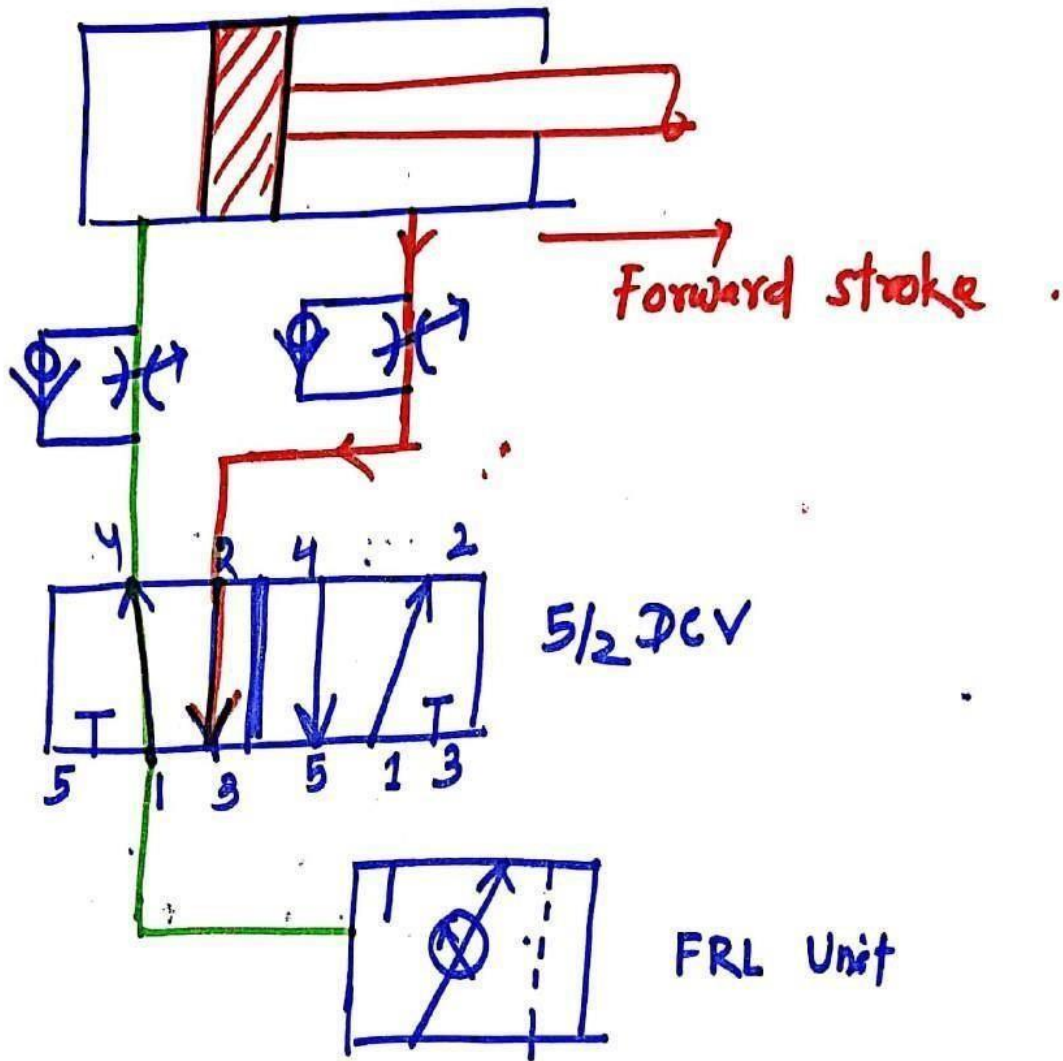

Hydraulic Systems

Introduction

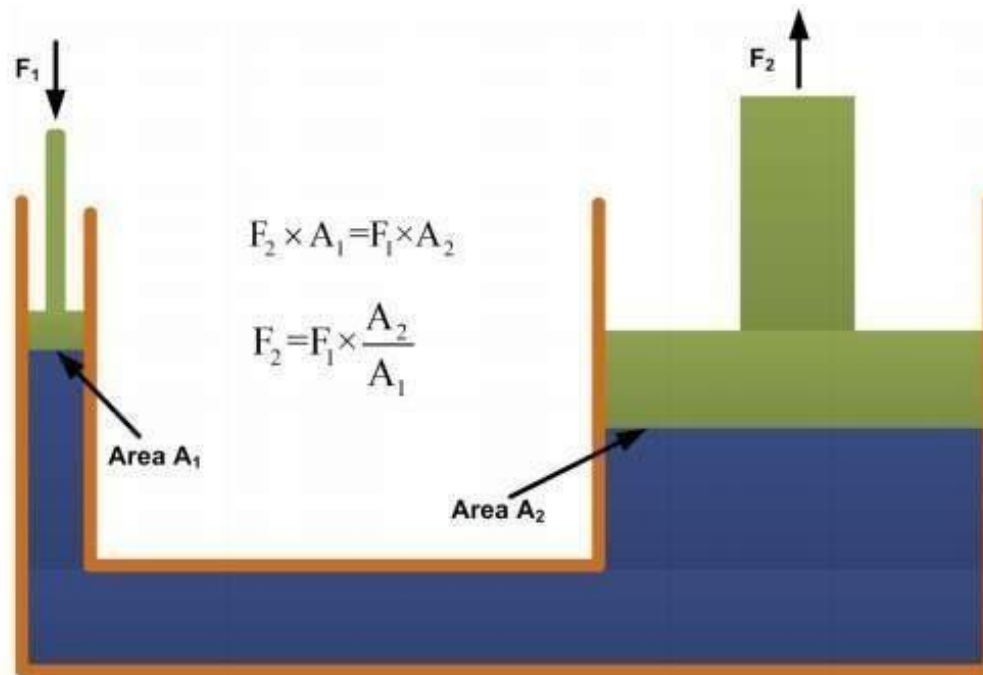

The hydraulic system works on the principle of Pascal's law which says that the pressure in an enclosed fluid is uniform in all the directions. The Pascal's law is illustrated in figure. The force given by fluid is given by the multiplication of pressure and area of cross-section. As the pressure is same in all the direction, the smaller piston feels a smaller force and a large piston feels a large force. Therefore, a large force can be generated with smaller force input by using hydraulic systems.

Hydraulic Systems

The hydraulic systems consists a number of parts for its proper functioning. These include storage tank, filter, hydraulic pump, pressure regulator, control valve, hydraulic cylinder, piston and leak proof fluid flow pipelines. The schematic of a simple hydraulic system is shown in figure 5.1.2

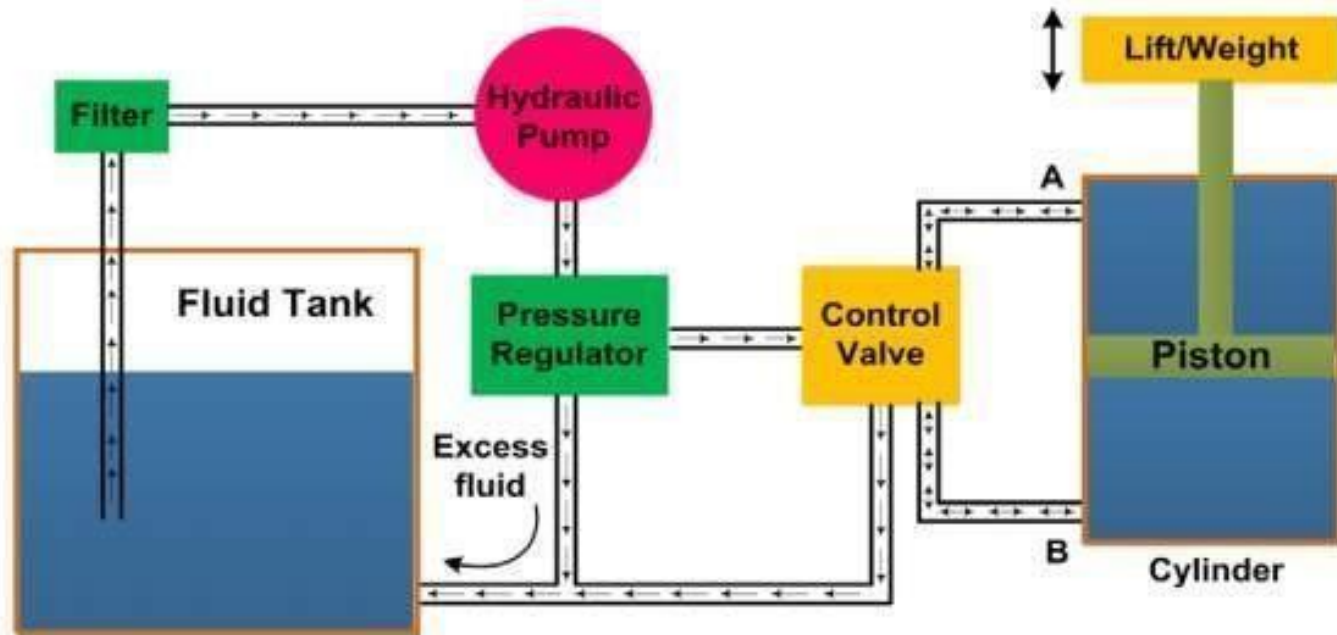

.It consists of:

- a movable piston connected to the output shaft in an enclosed cylinder
- storage tank
- filter
- electric pump
- pressure regulator
- control valve
- leak proof closed loop piping.

The output shaft transfers the motion or force however all other parts help to control the system. The storage/fluid tank is a reservoir for the liquid used as a transmission media. The liquid used is generally high density incompressible oil. It is filtered to remove dust or any other unwanted particles and then pumped by the hydraulic pump. The capacity of pump depends on the hydraulic system design. These pumps generally deliver constant volume in each revolution of the pump shaft. Therefore, the fluid pressure can increase indefinitely at the dead end of the piston until the system fails. The pressure regulator is used to avoid such circumstances which redirect the excess fluid back to the storage tank. The movement of piston is controlled by changing liquid flow from port A and port B. The cylinder movement is controlled by using control valve which directs the fluid flow. The fluid pressure line is connected to the port B to raise the piston and it is connected to port A to lower down the piston. The valve can also stop the fluid flow in any of the port. The leak proof piping is also important due to safety, environmental hazards and economical aspects. Some accessories such as flow control system, travel limit control, electric motor starter and overload protection may also be used in the hydraulic systems which are not shown in figure 5.1.2.

Applications of hydraulic systems

The hydraulic systems are mainly used for precise control of larger forces. The main applications of hydraulic systems can be classified in five categories:

1 Industrial: Plastic processing machineries, steel making and primary metal extraction applications, automated production lines, machine tool industries, paper industries, loaders, crushers, textile machineries, R & D equipment and robotic systems etc.

2. Mobile hydraulics: Tractors, irrigation system, earthmoving equipment, material handling equipment, commercial vehicles, tunnel boring equipment, rail equipment, building and construction machineries and drilling rigs etc.

3. Automobiles: It is used in the systems like breaks, shock absorbers, steering system, wind shield, lift and cleaning etc.

4. Marine applications: It mostly covers ocean going vessels, fishing boats and navel equipment.

5. Aerospace equipment: There are equipment and systems used for rudder control, landing gear, breaks, flight control and transmission etc. which are used in airplanes, rockets and spaceships.

Advantages and Disadvantages of Hydraulic system

Advantages

- • The hydraulic system uses incompressible fluid which results in higher efficiency.
- • It delivers consistent power output which is difficult in pneumatic or mechanical drive systems.
- • Hydraulic systems employ high density incompressible fluid. Possibility of leakage is less in hydraulic systems as compared to that in pneumatic system. The maintenance cost is less
- • These systems perform well in hot environment conditions

Disadvantages

- • The material of storage tank, piping, cylinder and piston can be corroded with the hydraulic fluid. Therefore one must be careful while selecting materials and hydraulic fluid.
- • The structural weight and size of the system is more which makes it unsuitable for the smaller instruments.
- • The small impurities in the hydraulic fluid can permanently damage the complete system, therefore one should be careful and suitable filter must be installed.
- • The leakage of hydraulic fluid is also a critical issue and suitable prevention method and seals must be adopted.
- • The hydraulic fluids, if not disposed properly, can be harmful to the environment.

Hydraulic Pumps

Classification of Hydraulic Pumps

These are mainly classified into two categories: A. Non-positive displacement pumps B. Positive displacement pumps.

.Non-Positive Displacement Pumps

These pumps are also known as hydro-dynamic pumps. In these pumps the fluid is pressurized by the rotation of the propeller and the fluid pressure is proportional to the rotor speed. These pumps can notwithstanding high pressures and generally used for low-pressure and high-volume flow applications. The fluid pressure and flow generated due to inertia effect of the fluid. The fluid motion is generated due to rotating propeller. These pumps provide a smooth and continuous flow but the flow output decreases with increase in system resistance (load). The flow output decreases because some of the fluid slip back at higher resistance. The fluid flow is completely stopped at very large system resistance and thus the volumetric efficiency will become zero. Therefore, the flow rate not only depends on the rotational speed but also on the resistance provided by the system. The important advantages of non-positive displacement pumps are lower initial cost, less operating maintenance because of less moving parts, simplicity of operation, higher reliability and suitability with wide range of fluid etc. These pumps are primarily used for transporting fluids and find little use in the hydraulic or fluid power industries. Centrifugal pump is the common example of non-positive displacement pumps. Details have already discussed in the previous lecture.

B. Positive displacement pump

These pumps deliver a constant volume of fluid in a cycle. The discharge quantity per revolution is fixed in these pumps and they produce fluid flow proportional to their displacement and rotor speed. These pumps are used in most of the industrial fluid power applications. The output fluid flow is constant and is independent of the system pressure (load). The important advantage associated with these pumps is that the high-pressure and low-pressure areas (means input and output region) are separated and hence the fluid cannot leak back due to higher pressure at the outlets. These features make the positive displacement pump most suited and universally accepted for hydraulic systems. The important advantages of positive displacement pump over non-positive displacement pumps include capability to generate high pressures, high volumetric efficiency, high

power to weight ratio, change in efficiency throughout the pressure range is small and wider operating range pressure and speed. The fluid flow rate of these pumps ranges from 0.1 and 15,000 gpm, the pressure head ranges between 10 and 100,000 psi and specific speed is less than 500.

It is important to note that the positive displacement pumps do not produce pressure but they only produce fluid flow. The resistance to output fluid flow generates the pressure. It means that if the discharge port (output) of a positive displacement pump is opened to the atmosphere, then fluid flow will not generate any output pressure above atmospheric pressure. But, if the discharge port is partially blocked, then the pressure will rise due to the increase in fluid flow resistance. If the discharge port of the pump is completely blocked, then an infinite resistance will be generated. This will result in the breakage of the weakest component in the circuit. Therefore, the safety valves are provided in the hydraulic circuits along with positive displacement pumps. Important positive displacement pumps are gears pumps, vane pumps and piston pumps. The details of these pumps are discussed in the following sections.

GearPumps

Gear pump is a robust and simple positive displacement pump. It has two meshed gears revolving about their respective axes. These gears are the only moving parts in the pump. They are compact, relatively inexpensive and have few moving parts. The rigid design of the gears and houses allow for very high pressures and the ability to pump highly viscous fluids. They are suitable for a wide range of fluids and offer self-priming performance. Sometimes gear pumps are designed to function as either a motor or a pump. These pump includes helical and herringbone gear sets (instead of spur gears), lobe shaped rotors similar to Roots blowers (commonly used as superchargers), and mechanical designs that allow the stacking of pumps. Based upon the design, the gear pumps are classified as:

- Externalgearpumps•Internalgearpumps•

Gerotor pumps

Generallygearpumpsareusedtopump:

- Petrochemicals:Pureorfilledbitumen,pitch,dieseloil,crudeoil,lube oil etc.
- Chemicals:Sodiumsilicate,acids,plastics,mixedchemicals,isocyanates etc.
- Paintandink•Resinsandadhesives•Pulpanpaper:acid,soap,lye, black liquor, kaolin, lime, latex, sludge etc.
- Food:Chocolate,cacaobutter,fillers,sugar,vegetablefatsandoils, molasses, animal food etc.

External gear pump

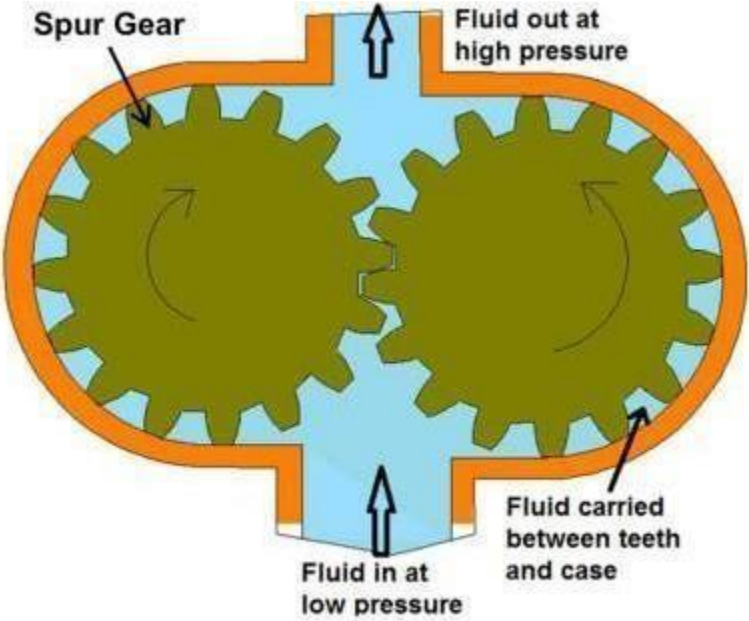

The external gear pump consists of externally meshed two gears housed in a pump case as shown in figure 5.2.1. One of the gears is coupled with a prime mover and is called as driving gear and another is called as driven gear. The rotating gear carries the fluid from the tank to the outlet pipe. The suction side is towards the portion where the gear teeth come out of the mesh. When the gears rotate, volume of the chamber expands leading to pressure drop below atmospheric value. Therefore the vacuum is created and the fluid is pushed into the void due to atmospheric pressure. The fluid is trapped between housing and rotating teeth of the gears. The discharge side of pump is towards the portion where the gear teeth run into the mesh and the volume decreases between meshing teeth. The pump has a positive internal seal against leakage; therefore, the fluid is forced into the outlet port. The gear pumps are often equipped with the side wear plate to avoid the leakage. The clearance between gear teeth and housing and between side plate and gear face is very important and plays an important role in preventing leakage. In general, the gap distance is less than 10 micrometers. The amount of fluid discharge is determined by the number of gear teeth, the volume of fluid between each pair of teeth and the speed of rotation. The important drawback of external gear pump is the unbalanced side load on its bearings. It is caused due to high pressure at the outlet and low pressure at the inlet which results in slower speeds and lower pressure ratings in addition to reducing the bearing life. Gear pumps are most commonly used for the hydraulic fluid power applications and are widely used in chemical installations to pump fluid with a certain viscosity

InternalGearPump

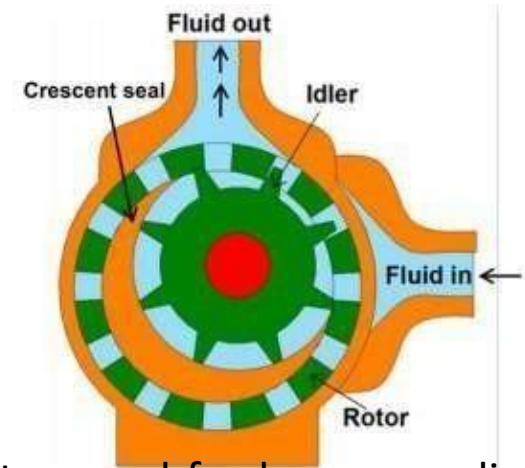

Internal gear pumps are exceptionally versatile. They are often used for low or medium viscosity fluids such as solvents and fuel oil and wide range of temperature. This is non pulsing, self-priming and can run dry for short periods. It is a variation of the basic gear pump. It comprises of an internal gear, a regular spur gear, a crescent-shaped seal and an external housing. The schematic of internal gear pump is shown in figure 5.2.4. Liquid enters the suction port between the rotor (large exterior gear) and idler (small interior gear) teeth. Liquid travels through the pump between the teeth and crescent. Crescent divides the liquid and acts as a seal between the suction and discharge ports. When the teeth mesh on the side opposite to the crescent seal, the fluid is forced out through the discharge port of the pump. This clearance between gears can be adjusted to accommodate high temperature, to handle high viscosity fluids and to accommodate the wear. These pumps are bi-rotational so that they can be used to load and unload the vessels. As these pumps have only two moving parts and one stuffing box, therefore they are reliable, simple to operate and easy to maintain. However, these pumps are not suitable for high speed and high pressure applications. Only one bearing is used in the pump therefore overhung load on shaft bearing reduces the life of the bearing.

Applications Some common internal gear pump applications are:

- All varieties of fuel oil and lube oil
- Resins and Polymers
- Alcohols and solvents
- Asphalt, Bitumen, and Tar
- Polyurethane foam (Isocyanate and polyol)
- Food products such as corn syrup, chocolate, and peanut butter
- Paint, inks, and pigments
- Soaps and surfactants
- Glycol